

# PFC-4410RC Installation, Operation, and Instruction Manual

## Releasing Panel for Water and Agent Extinguishing Systems

(All specifications subject to revision.)



St. Louis, MO  
(866) 956-0988  
[www.pottersignal.com](http://www.pottersignal.com)

Manual #5403550 - Rev R  
1/14



## WARRANTY INFORMATION

The essential purpose of any sale or contract for sale of any of the products listed in the POTTER catalog or price list is the furnishing of that product. It is expressly understood that in furnishing said product, POTTER does not agree to insure the Purchaser against any losses the Purchaser may incur, even if resulting from the malfunction of said product.

POTTER warrants that the equipment herein shall conform to said descriptions as to all affirmation of fact and shall be free from defects of manufacture, labeling and packaging for a period of one (1), one and one half (1.5), three (3), or five (5) year(s), depending on the product, from the invoice date to the original purchaser, provided that representative samples are returned to POTTER for inspection. The product warranty period is stated on the exterior of the product package. Upon a determination by POTTER that a product is not as warranted, POTTER shall, at its exclusive option, replace or repair said defective product or parts thereof at its own expense except that Purchaser shall pay all shipping, insurance and similar charges incurred in connection with the replacement of the defective product or parts thereof. This Warranty is void in the case of abuse, misuse, abnormal usage, faulty installation or repair by unauthorized persons, or if for any other reason POTTER determines that said product is not operating properly as a result of causes other than defective manufacture, labeling or packaging.

*The Aforesaid Warranty Is Expressly Made In Lieu Of Any Other Warranties, Expressed Or Implied, It Being Understood That All Such Other Warranties, Expressed Or Implied, Including The Warranties Of Merchantability And Fitness For Particular Purpose Are Hereby Expressly Excluded. In No Event Shall Potter Be Liable To Purchaser For Any Direct, Collateral, Incidental Or Consequential Damages In Connection With Purchaser's Use Of Any Of The Products Listed Herein, Or For Any Other Cause Whatsoever Relating To The Said Products. Neither Potter Nor Its Representatives Shall Be Liable To The Purchaser Or Anyone Else For Any Liability, Claim, Loss, Damage Or Expense Of Any Kind, Or Direct Collateral, Incidental Or Consequential Damages Relative To Or Arising From Or Caused Directly Or Indirectly By Said Products Or The Use Thereof Or Any Deficiency, Defect Or Inadequacy Of The Said Products. It Is Expressly Agreed That Purchaser's Exclusive Remedy For Any Cause Of Action Relating To The Purchase And/or Use Of Any Of The Products Listed Herein From Potter Shall Be For Damages, And Potter's Liability For Any And All Losses Or Damages Resulting From Any Cause Whatsoever, Including Negligence, Or Other Fault, Shall In No Event Exceed The Purchase Price Of The Product In Respect To Which The Claim Is Made, Or At The Election Of Potter; The Restoration Or Replacement Or Repair Of Such Product.*

**Potter Electric Signal Company, LLC**  
St. Louis, MO • (866) 956-0988

# CONTENTS

Installation Precautions .....	5
General Description .....	6
System Features .....	6
Options .....	8
Ordering Information .....	8
Specifications .....	9
PFC-4410RC Visual Indicators.....	9
LCD.....	9
PFC-4410RC Visual Indicators .....	9
Control Buttons .....	10
Circuit Parameters (All voltages regulated DC) - Initiating Device Circuits .....	10
Dedicated Supervisory Zone.....	10
Notification/Release Circuits .....	10
Low/Missing Battery .....	11
Input Power .....	11
Backup Power Requirements.....	12
Service Use .....	12
Listings and Approvals .....	12
Terminals.....	12
Relay Outputs.....	12
Annunciator Connection .....	12
Optional Accessories.....	12
Basic Operation.....	13
Low Air Alarm .....	13
Supervisory .....	13
Trouble Conditions .....	14
Notification Appliance/Releasing Circuits.....	14
Loss or Reduction of AC Power .....	14
Low Battery Voltage .....	15
Loss Of Auxiliary Power Output .....	15
To Silence the Buzzer (or outputs that have been described as trouble or supervisory bell).....	15
To Silence a Signaling Appliance .....	15
To Reset an Alarm or Supervisory Condition .....	15
To Reset A Trouble Condition.....	15
Lamp Test.....	16
Remote Annunciator Model RA-4410RC Operation.....	16
Test Procedure.....	16
Programming Mode Instructions .....	17
Panel Visual Display .....	17
PFC-4410RC Standard Program Information.....	21
PFC-4410RC Custom Program Information for Water Based Extinguishing Systems.....	73
Installation Instructions.....	83
Wire checkout .....	83
Mounting Instructions.....	84
PFC-4410RC False Front Removal/Assembly Drawing .....	84
Inactive Circuits.....	85
Operating Instructions Form .....	85
Battery Size Calculations.....	85
Battery Size Requirements And Maintenance .....	85
Current Requirements: Table 1 .....	86
Secondary Power Supply Requirements: Table 2 .....	86
Calculation Table .....	86
Typical 2-Wire Detector Connection Drawing .....	87
Typical 4-Wire Wiring Diagram .....	87

PFC-4410RC Connection Drawing .....	88
2-Wire Smoke Detector Compatibility Data.....	89
Releasing Device Capability.....	See Document 5403615
Wire Routing for PFC-4410RC .....	90
NEC Section 760-54 .....	91
Connection Procedure for Battery Charging Current and Voltage.....	92
Installation Of Bezel For Semi-flush Installations.....	92
Connection Drawing for Central Station and Remote Station Operation.....	93
Annex A: 4-Wire Smoke Detectors/Devices .....	94
Annex B: Product Datasheets of Optional Equipment .....	96

## Installation Precautions



**This is the safety alert system. It is used to alert you to potential personal injury hazards. Obey all safety messages that follow this symbol to avoid possible injury or death.**

### **WARNING**

The detection and suppression system employing this release panel must be designed by people trained and competent in the design and layout of fire alarm and/or suppression systems for special hazard locations. The system shall be designed and installed in accordance with all local and national codes and ordinances as well as the approval of the Authority Having Jurisdiction. Only trained, qualified and competent individuals should install, program and/or service the PFC-4410RC. Competent people would be aware of these warnings, limitations, and requirements.

The abort circuit will not abort the release or stop the predischage timer activated by zones programmed as MANUAL RELEASE. If it is desired to have the abort circuit stop the release activated from a Manual Release zone, program that zone as a DETECTION zone instead.

High voltage electrocution hazard. Do not handle live AC wiring or work on the device while AC power is active.

This manual is designed to help with the specification, installation, and programming of the PFC-4410RC Release Panel. It is imperative that this manual be completely read and understood before the installation or programming of the panel. Save this manual for future reference.

Zones programmed as MANUAL RELEASE will override any cross zoning features. If it is desired to not have a manual station override the cross zoning, program the zone as DETECTION and map accordingly.

Per ULC requirements; if this equipment is running on battery power only, it will shut off and cease to operate when the battery voltage reaches approximatly 19-20 volts.

### **CAUTION**

Locate the panel and all system components in the following nominal environment:

- \* Temperature 32-120°F, Humidity 93% non-condensing.
- \* Verify that the wire sizes are adequate for all initiating, notification, and release circuits.
- \* Make certain the panel is properly grounded.
- \* Remove all electronic assemblies prior to any drilling, filing, reaming, or punching of the enclosure. When possible make all cable entries from the sides, bottom, or rear of the cabinet. Verify that they will not interfere with the batteries or other components.
- \* The panel and system must be tested and maintained in accordance with all local and national codes and ordinances.

## **NOTICE**

### **Operating Instructions Form**

Fill in the name, address and telephone number of the servicing agency on the instruction sheet provided and frame and place adjacent to control panel at eye level.

The following documentation shall be delivered to the owner or their representative upon final acceptance of the system:

An owners manual and installation instructions covering all system equipment.

Wiring diagrams

A detailed description of the programming and operating sequence of the system

## **WARNING**

### **Fire Alarm System Limitations**

Smoke detectors may not detect smoke when the smoke does not reach the detector. Such as smoke within walls, on the other side of walls, on other floors, behind closed doors, explosions, etc. Smoke detectors will not operate if they are not properly connected to the fire/release panel. The detectors and bases must be UL listed as being compatible with the panel. The detectors have a visible flashing light that indicates power is supplied to the detectors.

Notification appliances may not alert people if the people are not able to hear or see the appliances such as if they are in separate areas of the building or room.

A fire alarm/release panel will not operate without electrical power. The panel must have sufficient backup battery capability to power the panel for a specified amount of time in the event of an AC power failure. The batteries and release panel shall be tested and maintained in accordance with the testing and maintenance requirements of NFPA 72.

In order for emergency forces, (Fire departments, etc.), to respond to events associated with this panel, the panel must transmit trouble, supervisory, and alarm signals to a monitoring facility either directly or through a main building fire panel.

A problem in an audible or visual device may not be apparent when the panel is in a normal condition.

### **Design Guidelines**

People trained in the design of special hazard systems shall determine the selection and placement of the initiating devices and notification appliances connected to the PFC-4410RC. This responsible party shall also be familiar with the premises being protected.

The equipment shall be installed in accordance with the manufacturers instructions, the applicable version of NFPA 72 and all local codes and ordinances. For systems employing cross zoning of two smoke detectors for the activation of the release circuit, this can include but is not limited to the installation of photoelectric and ionization types of detectors on separate zones. One of each type of detector on separate zones shall be installed in the coverage area selected for a single detector (not to exceed 0.7 times the linear spacing). The detectors would be installed in close proximity to each other.

The responsible party shall also determine the theory of operation regarding the programming sequence.

#### NOTICE TO ALL USERS, INSTALLERS, AHJ'S, AND OTHER INVOLVED PARTIES

This product incorporates field programmable software. In order to comply with the requirements in the Standard for Control Units and Accessories for Fire Alarm Systems, UL 864, certain programming features or options must be limited to specific values or not used at all, as indicated below.

Program Feature or Option	Permitted in UL 864	Possible Settings	Settings Permitted in UL 864
NY Abort (Mode 3)	No	Mode 1, 2, 3, or 4	Modes 1 and 2
30-Second Abort (Mode 4)	No	Mode 1, 2, 3, or 4	
Abort on Pre-action or Deluge Systems	No	Supervisory, Tamper, Low air, High Air, Abort	Supervisory, Tamper, Low Air, High Air

### **General Description**

The Model PFC-4410RC is a listed and approved, microprocessor based fire control/releasing panel. It is primarily designed for use as a releasing panel for pre-action and deluge, water based extinguishing systems or for agent extinguishing systems. The PFC-4410RC may also be used as a stand alone fire control panel. This unit complies with NFPA-12, NFPA-12A, NFPA-13, NFPA-15, NFPA -16, NFPA-17, NFPA-17A, NFPA-72, NFPA-750, NFPA-2001.

The PFC-4410RC complies with UL Standard 864, ULC S527-11, Canadian Electrical Code Part 1 C22.1., ULC S524, FM, CSFM, NYMEA, and is RoHS Compliant.

### **System Features**

• Four Class B (Style B) Initiating zones. Each initiating zone can be set up for any of the following:

- **Alarm Zones**
- Detection alarm zone
- Waterflow
- Linear Heat Detection (700 ohms per zone.)
- Manual Release

- **Supervisory Zones**

- Supervisory
- Tamper
- Low Air Supervisory
- High Air
- Low Air Alarm

NOTE: Only zones programmed as Detection, Waterflow, Linear Heat, Manual Release, and Low Air Alarm can be mapped to outputs programmed as release.

- Remote Annunciator Output for connection to RA-4410RC:
  - RS-485 communication, (2-wire shielded cable required)
  - Regulated 24VDC annunciator power
- Two Supervisory Zones, Class B (Style B). This zone can be set up for any of the following:
  - Supervisory
  - Tamper
  - Low Air Supervisory
  - High Air
  - \* Abort (Supervisory zone 1 only)

NOTE: \* Abort on a water-based extinguishing system is not a UL Listed function.
- Four Class B (Style Y) Output circuits. Each output can be set up for any of the following:
  - Notification Appliance circuit, (First or Second alarm notification in chemical extinguishing mode)
  - Releasing circuit
  - Pulse Releasing circuit (called eAEROSOL, 1/16th sec on 15/16th sec off. Chemical mode only, will cycle 200 times before turning off)
  - Supervisory Bell circuit
  - Trouble Bell circuit
- One Abort Circuit (Available in Chemical Mode only) Programmable for four different operating modes
  - ULI – Stops the pre-discharge timer at 10 seconds
  - IRI – Abort must be activated before the second alarm is received
  - NYC (not UL listed) A one time operation that adds 90 seconds to the remaining pre-discharge time
  - \* 30 Second Abort (stops or reverts the pre-discharge timer at 30 seconds)

NOTE: \* Not a UL Listed function

**⚠ CAUTION**

An eAEROSOL output shall only be used with Aerosol Generators (listed on page 90). Using a standard releasing circuit for an Aerosol Generator can prevent the Aerosol agent from being released.

**⚠ CAUTION**

Abort does not function and has no effect on panel operation from zones programmed as MANUAL RELEASE.

- Fifteen Standard Programs for water based systems or custom program capability
- Nine Standard Programs for Chemical based systems or custom program capability
- User selectable between Water Based or Chemical Extinguishing
- Releasing Zones can be set up for either normal or cross zoning operation
- Discharge time is user selectable for either 7, 8, 9, 10, 20 minutes or continuous in the custom program
- All circuits inherently power limited per NEC 760 and UL 864 Section 14.4
- Initiating Circuit Disable feature
- Output Disable feature
- One-Man Walktest feature with automatic 30 minute restoration and releasing circuit disable
- Class B (Style B) Abort circuit available in Chemical mode. Four Abort modes available
- Pre-Discharge timer from 0-60 seconds available in Chemical mode only
- Manual Release 0-30 seconds pre-discharge timer in Chemical Mode only
- Notification Appliance Circuits can be programmed to operate upon 1<sup>st</sup> or 2<sup>nd</sup> alarm in Chemical Mode for pre-discharge signal
- Diagnostic Indicators



- Signal Silence button
- Buzzer Silence button
- Manual event scroll buttons
- Automatic resound of silenced trouble signals after 24 hours
- Built-in Trouble buzzer
- Common Contacts for Alarm/Trouble/Supervisory/Waterflow
- 32 Character Liquid Crystal Display (LCD)
- 34 LED display
- User Generated Banner Message
- User Generated Zone Labeling
- 24 or 90 hour Battery Standby available (Where required by FM and Others)
- 24 Hour Clock
- Password Protection
- Remote annunciator output
- 4-Wire resettable smoke detector power

**Options** See Appendix B of the manual for product data sheets.

1. CAM - Module to convert one Class B Indicating Appliance Circuit to one Class A circuit.
2. CA2Z - Module to convert two Class B Initiating Device Circuits to two Class A circuits.
3. ARM-1 - Module to provide non-supervised 4PDT Relay designed to be activated by 24VDC Indicating and/or Releasing, polarity reversing circuits.
4. ARM-2 - Module to provide two Form C contacts activated by Indicating or Releasing, polarity reversing circuits.
5. ARM-44 - Module to provide 8 Form C contacts activated by corresponding initiating zones and outputs. Contact manufacture for data sheet 5401202.
6. RA-4410RC – Remote annunciator provides 34 LED's for each zone in alarm supervisory or trouble, each output activated or in trouble, AC power, Power trouble, System trouble, Ground fault, Supervisory, Supervisory trouble, Alarm, Alarm silence and Pre-discharge/Discharging. The annunciator also has a lamp test switch. Contact manufacture for data sheet 5401175.
7. Abort switch. Contact manufacture for data sheet 5401136.
8. RCDS-1 - Releasing Circuit Disable Switch Contact manufacture for data sheet 5401214.

**Ordering Information**

Model No.	Description	Stock No.
RA-4410RC	Remote annunciator	3006400
BB-RA-44R	Surface mount back box for RA-4410RC	3006401
EOLP-R	End of Line Plate f/Resistor	3002182
EOLP-D	End of Line Plate f/Diode Assy	3002181
P32-1T	Manual release station	1000447
	Abort Switch-Red	3001000
	Abort Switch-Blue	3001004
PFC-TW	Bezel for semi-flush mounting (white)	5090157
PFC-TR	Bezel for semi-flush mounting (red)	5090155
BT80	Battery, for 24 hour standby, 12V, 8.0AH (2 req'd)	5130084
BT120	Battery, for 60-90 hour standby, 12V, 12.0AH (2 req'd)	5130090
CA2Z	2-Zone Class A initiating module	3006013
CAM	Class A indicating circuit module	3005300
ARM-1	Auxiliary Relay Module 4 Pole	3004726
ARM-2	Auxiliary Relay Module	3004725
ARM-44	8 Relay Module	3006221
RCDS-1	Releasing Circuit Disable Switch	3001002

**Spare or Replacement Parts**

EOL Resistor	5080593
EOL Resistor and Diode Assembly for releasing circuit	3005012
EOL Resistor with 6" wire leads	3005013
eMatch Protection Assembly for eAEROSOL circuit	3005014
Main Circuit Board Module	3006230

**WARNING**

This equipment generates, uses, and can radiate radio frequency energy and if not installed and used in accordance with the instruction manual, may cause interference to radio communications. It has been tested and found to comply with the limits for a Class A computing device pursuant to Subpart J of Part 15 of FCC Rules which are designed to provide reasonable protection against such interference when operated in a commercial environment. Operation of this equipment in a residential area is likely to cause interference in which case the user at his own expense will be required to take whatever measures may be required to correct the interference.



**Specifications**

PFC-4410RC

Type - 18 gauge sheet steel with hinged, removable, locked door

Size - 18 1/2" x 14 1/4" x 4 3/4"

Finish - Off-white or red cabinet with red on black logo.

Knockouts - 1/2" and 3/4", one of each on left side, two 3/4" and one 1/2" on right side, four 1/2", two 3/4" on top, and two 1/2" and one 3/4" on the back

Option - Bezel for semi-flush mounting

**PFC-4410RC Visual Indicators**

LED Indicators (red = alarm)

32 Character Alpha-Numeric Liquid Crystal Display (LCD)

**LCD**

A 2 line 32 character alpha-numeric liquid crystal display shows the condition, status and circuit for all Alarm, Supervisory and Trouble conditions.

CONDITION	STATUS	CIRCUIT
Alarm	Silenced	<user Defined Message> (Up To 10 Characters)
Trouble	Disabled	Output #1
Supervisory	Acknowledged	Output #2
Tamper		Output #3
Low Air		Output #4
High Air		Battery
Aborted		A.C.
Pre-discharging		Supervisory
Releasing		Zone #1
Released		Zone #2
		Zone #3
		Zone #4
		Ground

**PFC-4410RC Visual Indicators**

In accordance with ULC S527-11 option B:

LED Annunciator Module

Red LED's: Initiating Device Circuits Active (4),  
Notification/Release Circuits Active (4)  
Common Alarm (1)

Green LED: Power on

Yellow LED's: Initiating Device Circuits Troubles (4),  
Output Circuits Troubles (4)  
Supervisory Initiating Zone (4)  
Supervisory Bell Output Active (4)

(1) each: Supervisory 1, Supervisory 2, Power Trouble, Supervisory Trouble, System Trouble, Earth Fault, Pre-Discharge/Discharging, Signal Silenced

CONDITION	STATUS	LED State
Trouble	Non-Silenced	Flashing
Trouble	Silenced	Steady ON
Alarm	Non-Silenced	Flashing
Alarm	Silenced	Steady ON
Supervisory	Non-Silenced	Flashing
Supervisory	Silenced	Steady ON
Pre-discharge		Flashing
Discharging		Steady ON

**Control Buttons**

- Signal Silence - Momentary, silences signaling circuits, (except those activated by zones programmed as WATERFLOW)
- System Reset - Momentary, resets all alarm circuits if condition has been corrected, removes power from initiating device circuits.
- Scroll Up - Scrolls LCD display to most recent events
- Scroll Down - Scrolls LCD display to previous events

NOTE: Trouble silence is accomplished by scrolling through all events.

**Circuit Parameters (All voltages regulated DC) - Initiating Device Circuits**

Initiating Device Zones: For connection of dry contact initiating devices and compatible 2 wire smoke detectors. (All values nominal)

- 4 Class B, Style B (Class A Style D module available)
- Power limited, current limited to protect 2 wire smoke detectors
- Maximum 2 wire 24VDC smoke detector load per zone - 2.5 mA (Use only detectors that are listed in compatibility list.)
- Maximum Line resistance - 100 ohms (Except linear heat detection cable, 700 ohms per zone)
- End-of-Line Resistance - 5.1K ohm
- Normal standby current - approximately 4.0 mA
- Standby voltage - 25VDC maximum, 13.4 minimum
- Maximum short circuit current - approximately 36mA
- Maximum Impedance for Alarm - 1400 ohms
- Normal supervisory current - approximately 4mA
- Low current trouble activation - approximately 3.3mA
- Alarm activation current - approximately 10mA
- Ripple voltage - .4VDC
- Maximum operating voltage range: 22.5 - 25.9VDC
- Frequency - continuous

**Dedicated Supervisory Zone**

- For dry contact supervisory devices such as tamper, low air, or high air switches
- 2 Class B Style B circuit, latching
- Power limited, current limited
- End-of-Line resistance - 5.1K ohms
- Ripple Voltage - .1VDC
- Frequency - continuous
- Maximum voltage - 25VDC
- Maximum short circuit current - approximately 36mA
- Maximum line resistance - 100 ohms
- Normal supervisory current - approximately 4mA
- Low current trouble activation - approximately 3.3mA
- Supervisory current condition - approximately 10mA

**Notification/Release Circuits**

The indicating circuits of the PFC-4410RC are Non-coded. This allows the use of visual and audible appliances on the same circuit. If temporal notification appliances are required for evacuation, selectable tone appliances such as the Potter EH24 horn or HS24 Series strobe/horns or a temporal module such as Potter AVSM or equivalents shall be used.

The notification outputs do not provide synchronization. The notification appliances shall be compatible with the sync module selected. The sync' module shall be installed as per manufacturers instructions. Synchronization is limited to only one circuit and not between circuits. Systems intended for the release of Halon 1301 as described in NFPA 12A, or clean agents as described in NFPA 2001, shall have provision for a pre-discharge notification circuit. If the signal is required to be separate and/or distinct from the evacuation signal, two notification circuits are required. One shall be programmed as FIRST ALARM. It will provide a steady output upon activation of any initiating zone programmed as an alarm zone. This is the evacuation signal. If a temporal signal is required, notification appliances such as Potter model EH24 or others that can produce a temporal tone shall be used. This allows the use of strobes and horns on the same circuit. The other notification circuit shall be programmed as SECOND ALARM. It will provide a steady output upon activation of a second initiating zone programmed as an alarm zone. This is when the pre-discharge timer would start and would be the pre-discharge signal. If a temporal or other type of signal is required, notification appliances such as Potter model EH24 or equivalent shall be used. This allows the use of strobes and horns on the same circuit. If a separate signal for discharge were required, a third notification circuit would be used that would be programmed to

operate whenever the release circuit is activated.

Zones programmed as MANUAL RELEASE will activate outputs programmed as SECOND ALARM, even if the MANUAL RELEASE zone is the first alarm zone activated. SECOND ALARM is intended to be used as a pre-discharge signal for cross zone applications. Refer to page 52 for a complete description of first and second alarm requirements and operation.

- 4 Class B Style Y (Class A Style Z module available for notification)
- Reverse polarity upon activation
- Power limited, Current limited
- Outputs identified as Release are Special Application. All other outputs are Regulated 24 VDC, rated 1 Amp each, 2.5 Amps total for all 4 circuits.
- End-of-Line-Resistor - 5.1k ohms
- Frequency - continuous
- Maximum voltage - 27VDC
- Ripple voltage - .3VDC
- Maximum impedance: 3 divided by NAC current draw
- Maximum resistance for outputs programmed as RELEASING:  
1 divided by the current draw of the solenoid when activated
- Normal standby supervisory current - approximately .38mA
- Low current trouble activation - .11mA
- High current trouble activation - .63mA

### Release Abort Circuit

- Available chemical mode only
- 1 momentary non-latching Class B Style B circuit
- Power limited, current limited
- Maximum loop resistance - 100 ohms
- End-of-Line-resistance - 5.1k ohms
- Frequency - continuous
- Normal supervisory current - approximately 4mA
- Low current trouble activation - approximately 3.3mA
- Abort current condition - approximately 10mA
- Maximum voltage - 23VDC

NOTE: Mode 3 is not UL Listed

Mode 1 – (ULI) Activation of the abort circuit stops the pre-discharge timer at 10 seconds. If there is less than 10 seconds remaining, the time goes back to 10 seconds. Releasing the abort switch starts the timer at 10 seconds.

Mode 2 – (IRI) Operates the same as the ULI mode except the abort circuit only functions if the abort button is pressed before the second alarm is received by the panel. The panel must be programmed for cross zoning for the IRI mode to function.

Mode 3 – (NYC) This mode is not UL listed. Activation of the abort circuit during the pre-discharge countdown adds 90 seconds to the original pre-discharge time. This is a one-time feature. Repeated pressing of the abort button has no effect. The pre-discharge timer resumes when the abort button is released.

Mode 4 – (30-Second Abort) This mode is not UL listed. Activation of the abort circuit stops the pre-discharge timer at 30 seconds. If there is less than 30 seconds remaining, the timer goes back to 30 seconds. Releasing the abort switch starts the timer at 30 seconds.

## CAUTION

Zones programmed as Manual Release cannot be aborted. If it is necessary to abort a manual station zone, program that zone as Detection.

If the pre-discharge timer is set at 0 the abort circuit will not stop the release circuit.

NFPA 12 prohibits the use of abort circuits on Suppression Systems employing carbon dioxide.

### Low/Missing Battery

Causes battery and system trouble if battery falls below 22 volts. Battery circuit is fused and reverse polarity protection is provided.

### Input Power

- Universal Input 120VAC, (60 Hz, 165VA) or 220VAC, (50/60 Hz, 185VA) 15 Amp Branch Line over current protection required
- AC Power indicator on LED annunciator module goes off on AC power loss (supervised)
- System trouble is also generated if voltage drops below 102V
- Supervised

## Backup Power Requirements

- PFC-4410RC - Standby 121 mA, alarm 274 mA at 24VDC, supervised

## Service Use

- NFPA 12 – Carbon Dioxide systems
- NFPA 12A – Halon 1301 fire systems
- NFPA 13 - Automatic Sprinkler
- NFPA 15 - Water Spray Fixed System
- NFPA 16 - Foam Water Sprinkler and Foam Water Spray
- NFPA 17 - Dry Chemical
- NFPA 17A - Wet Chemical
- NFPA 72 - National Fire Alarm Code
  - Local
  - Remote Station (protected premise unit)
  - Central Station (protected premise unit)
- NFPA 750 - Water Mist
- NFPA 2001 - Clean Agent Fire Extinguishing System

## Listings and Approvals

PFC-4410RC - UL Standard 864, ULC Standard S527, FM, CSFM, NYMEA, CE Marked, and RoHS Compliant.

## Terminals

- All terminals capable of #22 - #14 AWG wire
- All terminations have transient protection
- All four initiating device circuit terminals capable of handling linear heat detection.

## Relay Outputs

- Common system alarm contacts SPDT rated 3 Amps, 30VDC resistive
- Common supervisory contacts SPST, N.O. rated 3 Amps, 30VDC resistive
- Common system trouble contacts SPDT rated 3 Amps, 30VDC resistive
- Common waterflow contacts, SPST, N.O. rated 3 Amps, 30VDC resistive
- Circuits connected to relays should be connected within the same room\

## Auxiliary Power

- Auxiliary Power - 24VDC Special Application. Rated 200 mA max. Power limited, current limited, non-supervised
- Re-settable for 4-wire smoke detectors, see Annex A.

## Annunciator Connection

- Auxiliary Power - 24VDC regulated. Rated 200 mA max. Power limited, current limited, supervised for RA-4410RC Annunciator
- RS-485 For connection to RA-4410RC remote annunciator
- Maximum 2000' with 22 AWG, 4000' with 20 AWG wire

## Optional Accessories

CA2Z MODULE (Class A initiating device circuit):  
Converts two Class B initiating device circuits to two Class A circuits.

CAM Module (Class A Notification Appliance Circuit):  
Converts indicating appliance circuit from Class B to Class A. One model CAM (Class A Module) is required for each circuit. (Do not use this on an output programmed as “Trouble Bell”.)

ARM-1/ARM-2 Module (Auxiliary Relay Module)  
Activated by 24VDC Indicating and/or Releasing, polarity reversing circuits. The module provides a non-supervised DPDT Relay that can be used for fan shutdown, door release, elevator recall, etc.

RA-4410RC (Remote Annunciator)  
Connects to RS-485 & 24VDC terminals. Provides 34 LED's for each zone in alarm supervisory, or trouble, each output activated or in trouble, Power On, Power trouble, System trouble, Earth fault, Supervisory, Supervisory trouble, Alarm, Signal silence and Pre-discharge/Discharging.

The annunciator also has a lamp test switch.

ARM-44 (Relay Module) - Relay installs in a cabinet and provides 8 relays. 4 relays mapped to inputs and 4 relays mapped to the outputs in a 1 to 1 relationship selectable disable switch.

RCDS-1 (Release Circuit Disconnect Switch)

Provides physical means of disconnecting release circuits in compliance with NFPA 72.

### Basic Operation

In addition to the following events, the panel also provides an output via the RS-485 terminals to the RA-4410RC remote annunciator to light the appropriate indicators. See remote annunciator operations, page 16.

Initiating Device Circuits Alarm Condition:

An increase of current on any alarm initiating device circuit to approximately 10 mA or greater will result in the following: ALARM, (Except zones programmed as LOW AIR ALARM):

1. Activation of the alarm relay contacts.
2. Activation of the output circuit(s) which are mapped to the initiating device circuit(s). Providing all zone(s) necessary for the activation of those circuits is in alarm
3. "ALARM" and zone # displayed on LCD.
4. "PRE-DISCHARGE" displayed on LCD if zone(s) in alarm activated pre-discharge timer (In chemical mode only).
5. Activation of red ZONE indicator(s) on LED display for the initiating device circuit(s).
6. Activation of red ALARM indicator on LED display.
7. Activation of red OUTPUT indicator(s) on LED display module for the output circuit(s) which are mapped to the initiating device circuit(s).
8. Activation of flashing red PRE-DISCHARGE indicator on LED display if in chemical mode and pre-discharge timer was activated by zone(s) in alarm. Providing all zone(s) necessary for the activation of those circuits is in alarm.

## CAUTION

When in CHEMICAL EXTINGUISHING mode, the release circuit(s), are not activated until the pre-discharge timer expires, if a pre-discharge time was programmed. The predischarge time defaults to 30 seconds for Manual Release and 60 seconds for all other alarm tones.

### Low Air Alarm

1. Operation of supervisory relay contacts and local buzzer.
2. Activation of the notification appliance circuit(s) or releasing circuit(s) which are mapped to the initiating device circuit(s). Providing all zone(s) necessary for the activation of those circuits is in alarm.
3. LOW AIR ALARM and <CIRCUIT #> displayed on LCD.
4. Activation of yellow ZONE indicator on LED annunciator module for the initiating device circuit.
5. Activation of yellow ZONE indicator(s) on LED annunciator module for the initiating device circuit(s) described as "LOW AIR ALARM".
6. Activation of yellow OUTPUT indicator(s) on LED annunciator module for the output circuit(s) which are mapped to the zone. Providing all zone(s) necessary for the activation of those circuits is in alarm.
7. Activation of the amber supervisory LED in a flashing mode. **NOTE:** The supervisory LED will continue to flash until all events in the SUPERVISORY queue are viewed. This is accomplished by scrolling through all of the events by use of the scroll up and scroll down buttons. The LED will go steady after all alarm events have been viewed.

### Supervisory

An increase of current to approximately 8 mA or greater on the supervisory initiating device circuit(s) or disabling an output programmed as releasing will result in the following:

1. Operation of supervisory relay contacts and local buzzer.
2. Operation of any output circuits that have been described as SUPERVISORY BELL.
3. "SUPERVISORY", "TAMPER", "LOW AIR", or "HIGH AIR" and <CIRCUIT> displayed on LCD.
4. Activation of yellow SUPERVISORY indicator on LED display.
5. Activation of yellow ZONE indicator(s) on LED display for the initiating device circuit(s) described as "SUPERVISORY", "TAMPER", "LOW AIR SUPERVISORY", or "HIGH AIR".
6. Activation of yellow OUTPUT indicator(s) on LED display for the Notification appliance circuit(s) described as SUPERVISORY BELL.
7. Activation of the amber SUPERVISORY LED in a flashing modes well as the corresponding zone LED. **NOTE:** The SUPERVISORY LED will continue to flash until all events in the SUPERVISORY queue are viewed. This is accomplished by

scrolling through all of the events by use of the scroll up and scroll down buttons. The LED will go steady after all supervisory events have been viewed.

### Trouble Conditions

In custom program mode, failure to map at least 1 zone to every output or only mapping 1 zone to a release output programmed as cross zoned will cause a system trouble. The display will read: TROUBLE NO OUTPUTS.

### Initiating Device Circuits

A decrease of current to approximately 3.3 mA or programming the zone as disabled on any initiating device circuit will result in the following:

1. Activation of trouble relay contacts, trouble LED and local buzzer.
2. Operation of any output circuits which have been described as TROUBLE BELL.
3. "TROUBLE" and <CIRCUIT> displayed on LCD.
4. Activation of yellow ZONE indicator(s) on LED annunciator module for the initiating device circuit(s).
5. Activation of yellow SYSTEM TROUBLE indicator on LED annunciator module.
6. Activation of yellow OUTPUT indicator(s) on LED annunciator module of any output circuit(s) which have been described as TROUBLE BELL.
7. Activation of the amber TROUBLE LED in a flashing mode. NOTE: The TROUBLE LED will continue to flash until all events in the TROUBLE queue are viewed. This is accomplished by scrolling through all of the events by use of the scroll up and scroll down buttons. The LED will go steady after all trouble events have been viewed.

NOTE: When the circuits are operated in the Class A mode any trouble condition will require manual operation of the reset switch to restore the panel to normal after the fault has been removed.

A complete loss of power will result in the transfer of the common system trouble relay contacts.

### Notification Appliance/Releasing Circuits

An increase of current to approximately 0.63 mA or a decrease in current to approximately 0.11 mA on any output circuit or connecting an indicating appliance backwards, or disabling an output will result in the following:

1. Activation of trouble relay contacts, trouble LED and local buzzer.
2. Operation of any output circuits which have been described as TROUBLE BELL. If this output is in trouble, a TROUBLE BELL on this output may not function correctly, depending on the type of trouble.
3. "TROUBLE" and "OUTPUT #" <CIRCUIT NO.> displayed on LCD.
4. Activation of yellow OUTPUT indicator(s) on LED display for the notification appliance(s).
5. Activation of yellow SYSTEM TROUBLE indicator on LED display.
6. Activation of yellow OUTPUT indicator(s) on LED display of any output circuit(s) which have been described as TROUBLE BELL.

NOTE: A current in excess of 1.4 Amps, when the panel is in the alarm condition, will result in that output being disabled and a trouble as described above.

## CAUTION

A problem in an audible or visual device may not be apparent when the panel is in a normal condition. If the circuit indicates a trouble condition when the panel is in an alarm condition the problem must be located and corrected.

### Earth Fault

A short between any circuit and earth ground will result in the following:

1. Activation of trouble relay contacts, trouble and EARTH FAULT LEDs in a flashing mode, and local buzzer.
2. Operation of any output circuits which have been described as TROUBLE BELL.
3. "TROUBLE" and "GROUND" displayed on LCD.
4. Activation of the amber TROUBLE LED in a flashing mode. NOTE: The TROUBLE LED will continue to flash until all events in the TROUBLE queue are viewed. This is accomplished by scrolling through all of the events by use of the scroll up and scroll down buttons. The LED will go steady after all trouble events have been viewed.

### Loss or Reduction of AC Power

A reduction in the AC input voltage will result in the following:

1. Trouble LED and local buzzer will sound 1½ hour delay of trouble relay.
2. Operation of any output circuits which have been described as TROUBLE BELL.



3. "TROUBLE" and "A.C." displayed on LCD.
4. LCD Backlight will be extinguished.
5. Green AC POWER indicator on LED display will be extinguished.
6. Activation of yellow POWER TROUBLE indicator on LED display.
7. Activation of yellow SYSTEM TROUBLE indicator on LED display.
8. Activation of yellow OUTPUT indicator(s) on LED display of any output circuit(s) which have been described as TROUBLE BELL.

### Low Battery Voltage

Loss of or reduction of battery voltage to 22 volts will result in the following:

1. Activation of trouble relay contacts, trouble LED and local buzzer.
2. Operation of any output circuits that have been described as TROUBLE BELL.
3. "TROUBLE" and "BATTERY" displayed on LCD.
4. Activation of yellow POWER TROUBLE indicator on LED display.
5. Activation of yellow SYSTEM TROUBLE indicator on LED display.
6. Activation of yellow OUTPUT indicator(s) on LED display of any output circuit(s) which have been described as TROUBLE BELL.

### Loss Of Auxiliary Power Output

Loss of output of the auxiliary power will result in the following:

1. Activation of trouble relay contacts, trouble LED and local buzzer.
2. Operation of any output circuits that have been described as TROUBLE BELL.
3. "TROUBLE" and "AUX LOW" displayed on LCD.
4. Activation of yellow POWER TROUBLE indicator on LED annunciator module.
5. Activation of yellow SYSTEM TROUBLE indicator on LED annunciator module.
6. Activation of yellow OUTPUT indicator(s) on LED annunciator module of any output circuit(s) which have been described as TROUBLE BELL.
7. The remote annunciator RA-4410RC will not function if problem exists on nonresettable 24VDC.

### To Silence the Buzzer (or outputs that have been described as trouble or supervisory bell)

Press the scroll up or scroll down buttons. Once all events in the trouble or supervisory queue have been viewed, the buzzer and appropriate outputs will silence. The applicable system TROUBLE or SUPERVISORY LED will change from flashing to steady. NOTE: Any continuous trouble conditions that have been silenced automatically resound 24 hours after the first trouble condition was silenced.

### To Silence a Signaling Appliance

Press the SIGNAL SILENCE button. All silencable outputs will de-activate. A trouble condition will be created. The Amber Alarm Silence LED will light.

## CAUTION

Where audible and/or visual indicators are being used as an evacuation signal, do not silence an alarm condition without investigating and determining that an emergency condition does not exist.

### NOTES:

1. Alarms initiated from zones that are in the waterflow mode cannot be silenced. The panel must be reset to silence audible alarm devices.
2. If silenceable waterflow indication is desired it must be programmed as detection and annunciated on the zone identification portion of the LCD.

### To Reset an Alarm or Supervisory Condition

1. Determine the cause of the alarm condition and if necessary remove the cause.
2. Press the reset button.

### To Reset A Trouble Condition

1. Determine the cause of the trouble condition and remove the cause.
2. This circuit is self-restoring. When all trouble conditions are removed all indications will return to normal.

NOTE: When an initiating device zone is operated in a Class A (Style D) mode any trouble condition will require manual operation of the reset switch to restore the panel to normal after the fault has been corrected.



## Lamp Test

When the panel is in a Normal Condition, pushing the SCROLL-UP and SCROLL-DOWN buttons together will illuminate all of the LED's and display for approximately one second.

## Remote Annunciator Model RA-4410RC Operation

- Red LED's: Initiating Device Circuits Active (4)  
 Notification/Release Circuits Active (4)  
 Common Alarm (1)
- Green LED's: Power on
- Yellow LED's: Initiating Device Circuits troubles (4)  
 Output Circuit Troubles (4)  
 Supervisory Initiating Zone (4)  
 Supervisory Bell Output Active (4)  
 (1) each: Sup 1/Abort, Supervisory 2, Power Trouble,  
 Supervisory Trouble, System Trouble, Earth Fault,  
 Pre-Discharge/Discharging, Signal Silenced

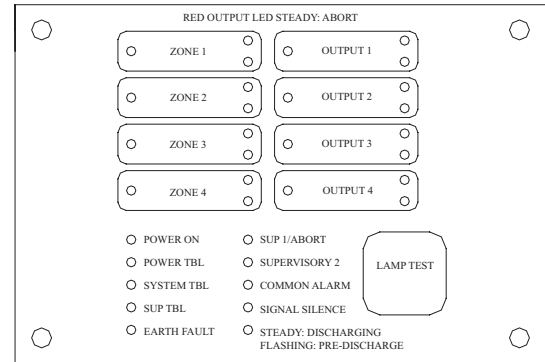

The appropriate LED flashes to indicate a change of status on the panel. A trouble or supervisory condition will flash the appropriate Yellow LED indicating the location of the condition. If any outputs are programmed as TROUBLE or SUPERVISORY BELL, that Yellow output LED will flash indicating the output is activated. Pressing the TROUBLE SILENCE button on the panel changes the flashing zone Amber LED to steady on and turns the flashing Yellow output LED off.

An alarm condition will flash a Red LED indicating the zone in alarm and any outputs mapped to that zone that have activated. Pressing the SIGNAL SILENCE button changes the flashing Red Zone LED to steady on and the flashing Red Output LED mapped to that zone off unless the output is programmed as RELEASE. In addition, the Yellow SIGNAL SILENCE LED will light.

Any zone programmed as WATERFLOW is considered non-silenceable so the SIGNAL SILENCE button will have no effect on the flashing zone and output LED's. A buzzer on the annunciator sounds for any trouble condition. Pressing the LAMP TEST button can be used to test the LED's.

The release panel supervises and communicates with the annunciator via separate connections for the RS-485 communication and 24VDC power requirements of the RA-4410RC. Separate cables should be used for power and communication. Shielded cable shall be used for the communication line. Up to four annunciators can be connected to one panel. A rotary switch is provided on the panel to indicate how many annunciators are connected. Another rotary switch is on the annunciator to set the address. The annunciators must be addressed consecutively. See page 89 for wiring information. Refer to bulletin #8840024 for installation instructions and maximum wire run.

## Test Procedure

The system should be inspected, tested and maintained in accordance with NFPA-72 National Fire Alarm Code and any other requirements of the local authority having jurisdiction.

### Test Procedure (Canada)

The system should be inspected, tested and maintained in accordance with ULC Standard CAN/ULC-S536 and any other requirements of the local authority having jurisdiction.

## Testing should be done as a minimum as described below

1. Notify the fire department or other receiving station if alarm, supervisory and/or trouble signals are transmitted.
2. Notify the proper building personnel so that audible and/or visual signals can be ignored.
3. If the release panel is monitored by a building fire alarm panel, take appropriate action to eliminate any unwanted events.
4. Momentarily open each of the following circuits.
  - Each initiating device zone
  - Supervisory circuit
  - Notification Appliance/Releasing circuit - observe that this results in a trouble condition and all indicators operate as described in the appropriate preceding section for the particular circuit that is faulted.

5. Move the PROGRAM switch down. The LCD should respond: "LOOK AT HISTORY?". Press the FUNCTION button until the display reads: "PASSWORD=000". Press the SET button three times. Press the FUNCTION button until the LCD reads "SYSTEM MODE: NORMAL". Press the SELECT button. The LCD will read "SYSTEM MODE: ONE MAN WALKTEST". Press the SET button then move the PROGRAM switch up. The panel will respond with "ONE MAN WALKTEST" and the time. The trouble LED will light. Any output described as "RELEASING" will automatically be disabled.

**Note:** The RCDS-1, Release Circuit Disconnect Switch, shall be used to provide physical means of disconnecting the release circuit in compliance with NFPA 72.

**⚠ WARNING**

Failure to enter the walktest mode and subsequent operation of initiating zones may result in a release.

**After 30 minutes of no activity in the walk test mode the panel automatically reverts to normal operation.**

6. Operate each initiating device on all zones. All audible and visual alarm devices should operate for about 3 seconds. Then the system will automatically reset allowing the user to go to the next initiating device.
7. Operate each initiating device on the supervisory circuit. Observe that all the indications described in the section on supervisory conditions occur.
8. Move the PROGRAM switch down again. The LCD should respond: "LOOK AT HISTORY?". Press the FUNCTION button until the LCD reads: PASSWORD=000, enter the password. Press the FUNCTION button until the display reads: "SYSTEM MODE: ONE MAN WALKTEST". Press the SELECT button. The LCD will read: "SYSTEM MODE: NORMAL". Press the SET button then restore the PROGRAM switch to the up position. The LCD will show the normal banner message.
9. All audible and visual indicators should be off.
10. Notify all building, fire department, and/or other receiving station personnel that the test has concluded.

**Maintenance**

Test batteries per local and national standards. At a minimum replace batteries every four (4) years or sooner depending on test results. The date of purchase shall be marked on all batteries.

**Programming Mode Instructions**

To use the Programming Mode push the program switch to the right (see drawing below).

**Panel Visual Display**

As a general rule, the following applies on the Programming Mode buttons:

- The SET button sets the message on the display into the memory.
- The SELECT button scrolls through the selections available for the function displayed.
- The FUNCTION button allows the user to skip the function without changing the program.

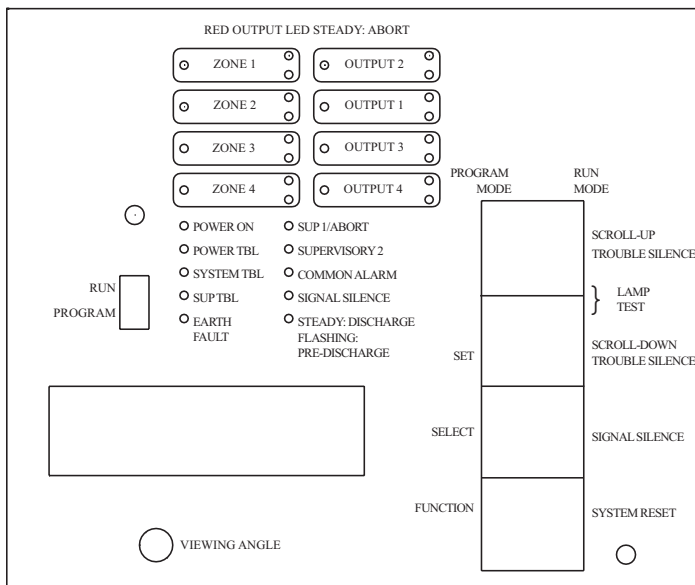

DWG# 3550-18

**⚠ WARNING**

After 30 minutes of no activity, the panel will automatically exit Program Mode and revert to run mode.

To program, push the Program Switch down.

There is no capability to back up screens in the program mode. If a mistake was made during programming, move the program switch back up, then move it down and start from the beginning.

To exit the program mode at any time, move the Program Switch to the left.

When the programming switch is down (see Panel Visual Display) the following will appear in the display window:

L	O	O	K		A	T								
H	I	S	T	O	R	Y	?							

**History**

To examine the HISTORY press the SET button, the display window will show the time and date of the last event or action. To skip to the next function or to exit history, press the FUNCTION button.

**SET**  Press the SET button to discover the time and date of the last event or action and to scroll forward.

**SELECT**  To scroll back, press the SELECT button.

**FUNCTION**  To exit or skip HISTORY, press the FUNCTION button.

After pressing the FUNCTION button the following will appear in the display window:

S	E	T		T	I	M	E	?						

**Date and Time**

**SELECT**  To change the time, press the SELECT button.

**FUNCTION**  To exit to the next function, press the FUNCTION button.

If the SELECT button is pushed, the date and time will appear in the display window:

					0	1	/	0	5	/	2	0	0	7	
M	I	N	U	T	E	S		0	5	:	1	9	:	3	5

The date is shown at the top and the time at the bottom of the display window. "MINUTES" indicates that the user can now change the minutes.

**SET**  Pressing the SET button will decrease the minutes.

**SELECT**  Pressing the SELECT button will increase the minutes.

**FUNCTION**  When finished setting the minutes, Press the FUNCTION button. The minutes will change to hours.

Continue this process and change the DAY, MONTH and YEAR. When you have finished changing the year, press the FUNCTION button. A display similar to the following will appear:

P	A	S	S	W	O	R	D	=	0	0	0			
									^					

**Password**

This display prevents unauthorized programming of the panel by requiring the user to enter the proper password. To select the appropriate number for the space indicated by the ^ symbol, press the SELECT button. When the proper number is displayed press the SET button to set the number and move to the next space. If the wrong password is entered, the panel will automatically return to a normal condition. All panels are shipped from the factory with a password of 000. If the password is lost contact Potter.

**SET**  After selecting the desired number, press the SET button to set and move to the next number.

**SELECT**  Press the SELECT button to scroll through the numbers.

**FUNCTION**  Pressing the FUNCTION button will have no effect.

After entering the correct password, a display similar to the following will appear:

I	N	I	T		Z	O	N	E		#	1				
E	N	A	B	L	E	D									

**Zone Disabled/Enabled**

This display allows the user to ENABLE or DISABLE Initiating zones. This display window shows that initiating ZONE #1 is enabled. To toggle from ENABLED to DISABLED or visa versa, press the SELECT button.

**SET**  After selecting ENABLED or DISABLED, press the SET button to set and move to the next zone.

**SELECT**  Press the SELECT button to toggle between ENABLED or DISABLED.

**FUNCTION**  To skip to the next function, press the FUNCTION button.

After selecting all four zones or pressing the FUNCTION button, the following will appear in the display window:

O	U	T	P	U	T		#	1							
E	N	A	B	L	E	D									

**Output Enable/Disable**

This display allows the user to ENABLE or DISABLE any of the output circuits.

**SET**  After selecting ENABLED or DISABLED, press the SET button to set and move to the next output.

**SELECT**  Press the SELECT button to toggle between ENABLED or DISABLED.

**FUNCTION**  To skip to the next function, press the FUNCTION button.

After selecting all four outputs or pressing the FUNCTION button, the following will appear in the display window:

**NOTICE**

Disabling any input or outputs will create a trouble condition on the panel.

S	Y	S	T	E	M		M	O	D	E	:				
N	O	R	M	A	L										

**One Man Walktest**

This display allows the user to select system mode NORMAL or ONE MAN WALKTEST by pressing the SELECT button to toggle back and forth from NORMAL to ONE MAN WALKTEST. When the desired mode is displayed, press the SET button. If ONE MAN WALKTEST is selected for test purposes, the display must be restored to the NORMAL setting after the test is completed by toggling to it using the SELECT button.

 <b style="font-size: 1.2em;">WARNING</b>
After 30 minutes of no activity the panel automatically reverts to normal.

**Note:** NFPA 72 requires a physical means of disconnecting release circuits. The Potter Model, RCDS-1, complies with those requirements.

**SET**  After selecting NORMAL or ONE MAN WALKTEST, press the SET button to set that mode.

**SELECT**  Press the SELECT button to toggle between NORMAL and CROSS ZONED.

**FUNCTION**  Press the FUNCTION button to skip to the next function.

After selecting the operating mode or pressing the FUNCTION button a display similar to the following will appear in the display window:

P	R	O	G	R	A	M		#	0						

**PFC-4410RC Standard Program Information**

The PFC-4410RC has 24 standard programs which are detailed in the following pages. Selecting one of these programs will automatically program every function of the panel except the custom banner and zone message functions.

**NOTES:**

The release discharge time is continuous for all 24 programs.

In the chemical extinguishing programs the pre-discharge timer defaults to 60 seconds, manual release pre-discharge timer defaults to 30 seconds, the abort mode defaults to UL.

The following is an explanation of how the various programs operate and information about the types of devices that are to be connected to the input and output zones.

If none of the standard programs are acceptable for the installation required, select the custom program #0 then press the SET button. This will allow the user to custom program the panel. Turn to page 72 for custom program information.

	<b>Type</b>	<b>Description</b>
<b>Alarm Zones</b>	Detection	Smoke Detectors, Spot Type Heat Detectors
	Waterflow	PS10 Pressure Switch
	Linear Heat	Cable Type Heat Detectors
	Manual Release	Pull Stations
<b>Supervisory Zones</b>	Supervisory	Valve Tamper, Low Air, High Air, Room Temperature
	Low Air supervisory	Low Air Switch
	High Air	High Air Switch
	Tamper	Valve Tamper Switch
	Low Air Alarm *	PS10, PS40
<b>Outputs</b>	Alarm	24VDC Bells, Horns, Strobes, to indicate an alarm condition.
	Release	Solenoid Valve, Squib, Releasing Mechanism
	eAEROSOL	Aerosol Generator
	Supervisory	24VDC Bells, Horns, Strobes, to indicate a supervisory condition.
	Trouble	24VDC Bells, Horns, Strobes, to indicate a trouble condition.

To program the PFC-4410RC to operate with one of the following 24 standard programs:

The water based extinguishing programs are numbered 1-15. The chemical extinguishing programs are numbered 20-28. A description, theory of operation, and wiring diagrams for all standard programs start on the next page.

1. Press SELECT button to scroll to the program number (#1 through #15, #20 through #28) you desire.
2. Press SET button.
3. Turn to page 81 to program the banner message and to finish programming the panel.

<b>SET</b>	<input type="checkbox"/>	After selecting the proper program number, press the SET button to set the program and move to the next function.
<b>SELECT</b>	<input type="checkbox"/>	Press the SELECT button to scroll through the programs.
<b>FUNCTION</b>	<input type="checkbox"/>	Press the FUNCTION button to skip to the next function.

**NOTICE**

After selecting the desired program number with the SELECT button, SET button **must** be pressed to set the program.

**\*Not available on Supervisory Zones: Sup 1 or Sup 2.**

Wiring Diagram Program #1  
 Single Hazard, 3 Alarm Zones with 1  
 Waterflow Zone and 2 Supervisory Zones

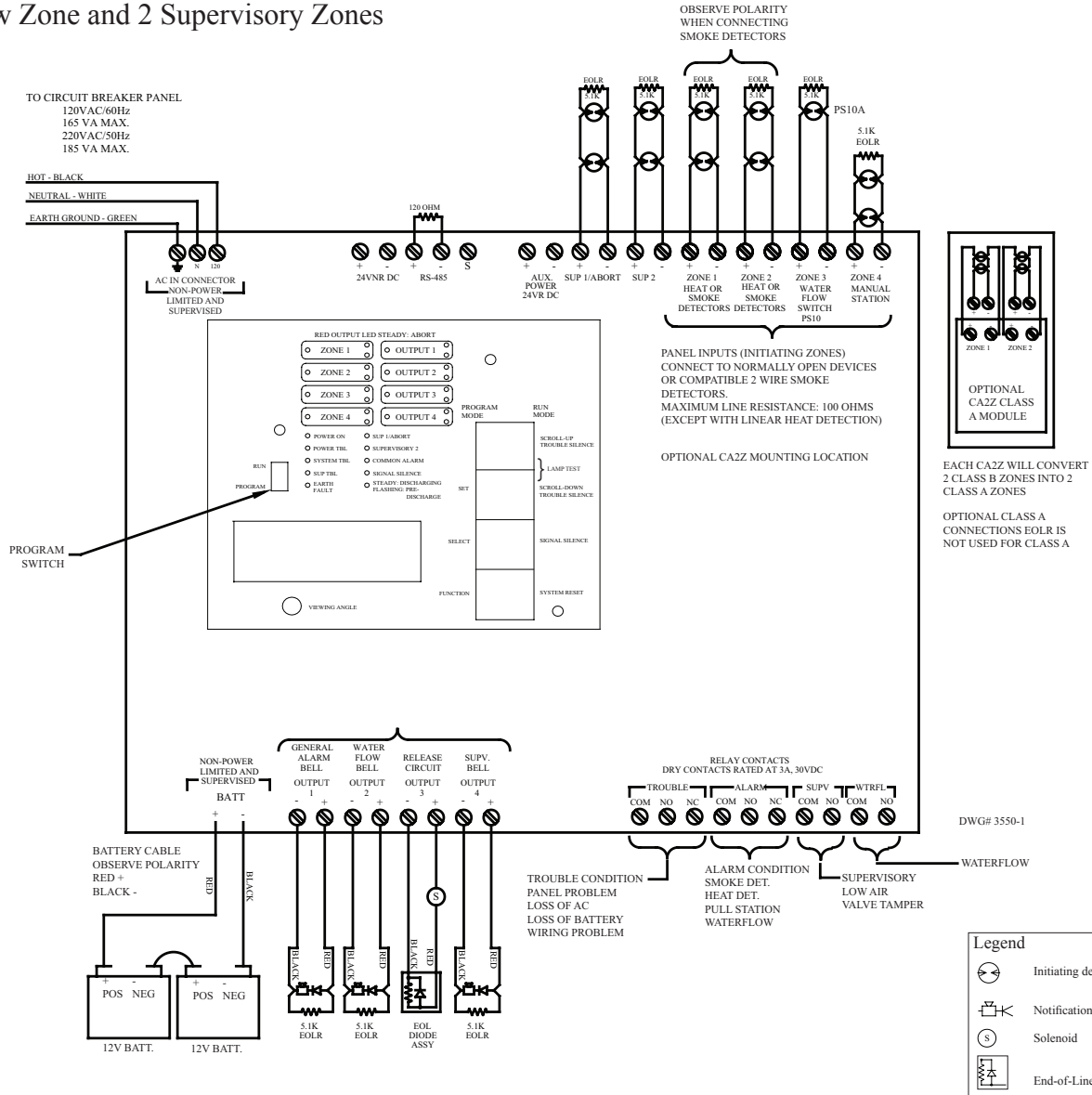

NOTES:

1. Connect only UL Listed 24VDC devices to indicating circuits.
2. Connect EOL Diode assembly IN SERIES with solenoid on release circuit
3. Leave EOLR (provided) on all unused circuits.
4. Polarity is shown on indicating circuits in an activated (off-normal) condition.
5. Polarity reverses when output is activated.
6. Maximum current per output is 1 Amp. Maximum voltage is 33 VDC.
7. Outputs identified as Release are Special Application. All other outputs are Regulated 24 VDC, Rated 1 Amp each, 2.5 Amp total for all 4 circuits.
8. All initiating and NAC/Release circuits are supervised and power limited. See note 3 on page 90 for power limited wire routing instructions. All frequencies are continuous.
9. Refer to pgs. 16, 83-85 for installation, test and maintenance information.
10. Maximum resistance on outputs is 10 ohms. Maximum resistance on outputs programmed as releasing, is 1 divided by current requirements of solenoid.
11. Notification outputs do not provide synchronization. If synchronization is needed, refer to the NAC Compatibility Document, 5403592. Synchronization is only on one circuit and not between circuits. The maximum cannot exceed 1 amp or whatever the maximum that the sync' module can support, whichever is lower.

See page 89 for smoke detector compatibility data.

See page 85 for battery information.



**Program #1 Mode**

1. Apply power to panel.
2. Move the program switch down.
3. Press the FUNCTION button until the display reads “PASSWORD = 000”.
4. To enter a password, press the SELECT button until the proper number is displayed above the ^ symbol, then press the SET button to move to the next digit. After entering the third number the display will change. (All panels are shipped with a 000 password.)
5. Press the FUNCTION button until the display reads “PROGRAM #0”.
6. Press the SELECT button until the display reads “PROGRAM #1”.
7. Press the SET button.
8. The panel is completely programmed except for the custom banner and zone messages. Move the program switch back up.

PROGRAM #1						
	ZONES					
	SUP 1	SUP 2	#1	#2	#3	#4
OUTPUTS	Supervisory		Detection	Detection	Waterflow	Manual Release
#1 ALARM INDICATING			X	X		X
#2 ALARM INDICATING					X	
#3 RELEASE			X	X		X
#4 SUPERVISORY	X	X				

Description: Single hazard - 3 zone  
 Inputs: 2 detection zones, 1 waterflow zone, 1 manual release zone, 2 supervisory zones  
 Outputs: 1 general alarm bell, 1 waterflow bell, 1 solenoid release circuit, 1 supervisory bell  
 Operation: Activation of either detection zone or the manual release zone will operate the release circuit and general alarm output.  
 Activation of the waterflow zone will operate the waterflow bell output.  
 Activation of the supervisory zone will operate the supervisory bell output.

When either zone 1, 2 or 4 is in alarm - output #1 (general alarm) and output #3 (solenoid release) will operate.  
 When zone 3 is in alarm - output #2 will operate (waterflow bell).  
 When the supervisory zone is activated - output #4 will operate (supervisory bell).

Wiring Diagram Program #2  
 Single Hazard, 2 Alarm Zones (Cross-Zoned), 1 Manual  
 Station Zone, 1 Waterflow Zone, and 2 Supervisory Zones

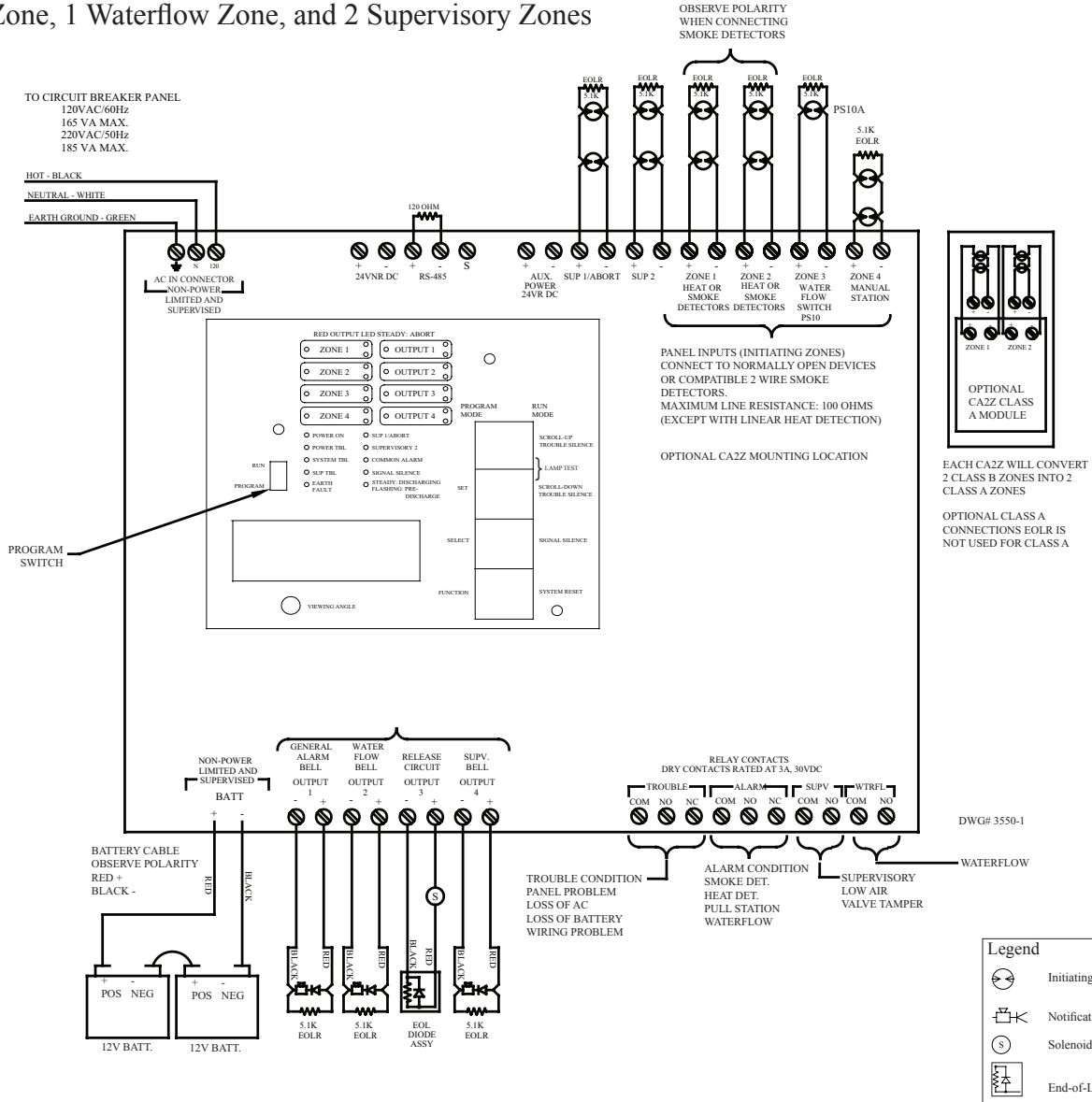

NOTES:

1. Connect only UL Listed 24VDC devices to indicating circuits.
  2. Connect EOL Diode assembly IN SERIES with solenoid on release circuit
  3. Leave EOLR (provided) on all unused circuits.
  4. Polarity is shown on indicating circuits in an activated (off-normal) condition.
  5. Polarity reverses when output is activated.
  6. Maximum current per output is 1 Amp. Maximum voltage is 33VDC.
  7. Outputs identified as Release are Special Application. All other outputs are Regulated 24 VDC, Rated 1 Amp each, 2.5 Amp total for all 4 circuits.
  8. All initiating and NAC/Release circuits are supervised and power limited. See note 3 on page 90 for power limited wire routing instructions. All frequencies are continuous.
  9. Refer to pgs. 16, 83-85 for installation, test and maintenance information.
  10. Maximum resistance on outputs is 10 ohms. Maximum resistance on outputs programmed as releasing, is 1 divided by current requirements of solenoid.
  11. Notification outputs do not provide synchronization. If synchronization is needed, refer to the NAC Compatibility Document, 5403592. Synchronization is only on one circuit and not between circuits. The maximum cannot exceed 1 amp or whatever the maximum that the sync' module can support, whichever is lower.
- See page 89 for smoke detector compatibility data.  
 See page 85 for battery information.

**Program #2 Mode**

1. Apply power to panel.
2. Move the program switch down.
3. Press the FUNCTION button until the display reads “PASSWORD = 000”.
4. To enter a password, press the SELECT button until the proper number is displayed above the ^ symbol, then press the SET button to move to the next digit. After entering the third number the display will change. (All panels are shipped with a 000 password.)
5. Press the FUNCTION button until the display reads “PROGRAM #0”.
6. Press the SELECT button until the display reads “PROGRAM #2”.
7. Press the SET button.
8. The panel is completely programmed except for the custom banner and zone messages. Move the program switch up.

PROGRAM #2						
	ZONES					
	SUP 1	SUP 2	#1	#2	#3	#4
OUTPUTS	Supervisory		Detection	Detection	Waterflow	Manual Release
#1 ALARM INDICATING			X	X		X
#2 ALARM INDICATING					X	
#3 RELEASE			XX	XX		X
#4 SUPERVISORY	X	X				

XX = Cross-Zoned

Description: Single hazard, cross zone with manual station override.

Inputs: 2 detection zones (cross zoned), 1 waterflow zone, 1 manual release zone, 2 supervisory zones

Outputs: 1 general alarm bell, 1 waterflow bell, 1 solenoid release circuit, 1 supervisory bell

Operation: Activation of both detection zones at the same time, or activation of the manual release zone will operate the release output and the general alarm output.

Activation of one detection zone will operate the general alarm output.

Activation of the waterflow zone will operate the waterflow bell output.

Activation of the supervisory zone will operate the supervisory bell output.

When zone 1, 2 or 4 is in alarm - output #1 will operate (general alarm bell).

When zone 3 is in alarm - output #2 will operate (waterflow bell).

When both zones 1 and 2 are in alarm at the same time - output #3 will operate (solenoid release).

When zone 4 is in alarm - outputs #3 (solenoid release) and #1 (general alarm) will operate.

# Wiring Diagram Program #3

## Dual Hazard, Combined Release - 2 Alarm Zones, 1 Manual Station Zone, 1 Waterflow Zone, and 2 Supervisory Zones

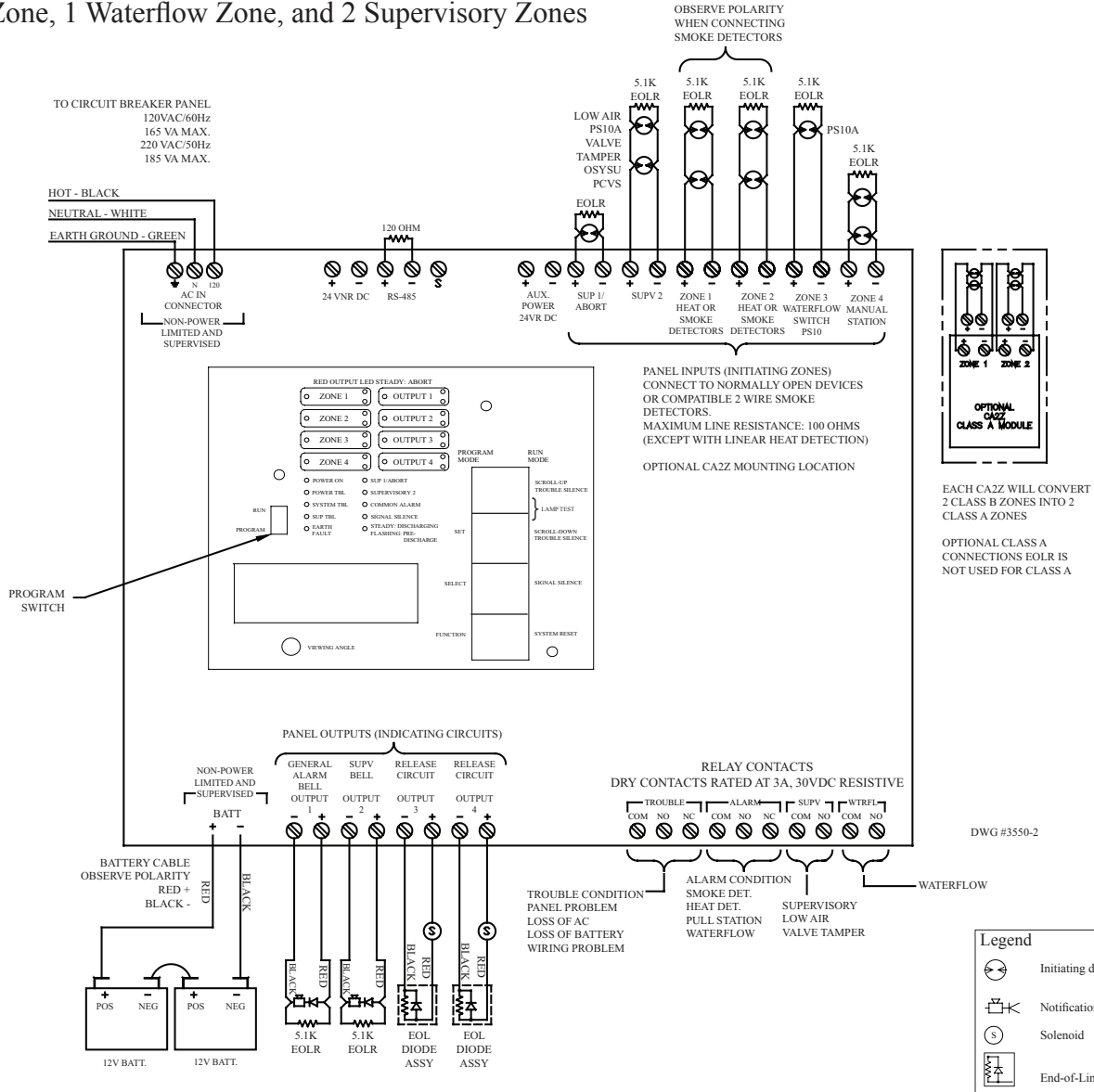

**NOTES:**

1. Connect only UL Listed 24VDC devices to indicating circuits.
  2. Connect EOL Diode assembly IN SERIES with solenoid on release circuit
  3. Leave EOLR (provided) on all unused circuits.
  4. Polarity is shown on indicating circuits in an activated (off-normal) condition.
  5. Polarity reverses when output is activated.
  6. Maximum current per output is 1 Amp. Maximum voltage is 33VDC.
  7. Outputs identified as Release are Special Application. All other outputs are Regulated 24 VDC, Rated 1 Amp each, 2.5 Amp total for all 4 circuits.
  8. All initiating and NAC/Release circuits are supervised and power limited. See note 3 on page 90 for power limited wire routing instructions. All frequencies are continuous.
  9. Refer to pgs. 16, 83-85 for installation, test and maintenance information.
  10. Maximum resistance on outputs is 10 ohms. Maximum resistance on outputs programmed as releasing, is 1 divided by current requirements of solenoid.
  11. Notification outputs do not provide synchronization. If synchronization is needed, refer to the NAC Compatibility Document, 5403592. Synchronization is only on one circuit and not between circuits. The maximum cannot exceed 1 amp or whatever the maximum that the sync' module can support, whichever is lower.
- See page 89 for smoke detector compatibility data.
- See page 85 for battery information.

**Program #3 Mode**

1. Apply power to panel.
2. Move the program switch down.
3. Press the FUNCTION button until the display reads “PASSWORD = 000”.
4. To enter a password, press the SELECT button until the proper number is displayed above the ^ symbol, then press the SET button to move to the next digit. After entering the third number the display will change. (All panels are shipped with a 000 password.)
5. Press the FUNCTION button until the display reads “PROGRAM #0”.
6. Press the SELECT button until the display reads “PROGRAM #3”.
7. Press the SET button.
8. The panel is completely programmed except for the custom banner and zone messages. Move the program switch back up.

PROGRAM #3						
	ZONES					
	SUP 1	SUP 2	#1	#2	#3	#4
OUTPUTS	Supervisory		Detection	Detection	Waterflow	Manual Release
#1 ALARM INDICATING			X	X	X	X
#2 SUPERVISORY	X	X				
#3 RELEASE			X	X		X
#4 RELEASE			X	X		X

Description: Dual hazard, combined release.  
 Inputs: 2 detection zones, 1 waterflow zone, 1 manual release zone, 2 supervisory zones  
 Outputs: 1 general alarm bell, 1 supervisory bell, 2 solenoid release circuits  
 Operation: Activation of either detection zone or the manual release zone will activate both solenoid release outputs and the general alarm bell.  
 Activation of the waterflow zone will operate the general alarm bell.  
 Activation of the supervisory zone will operate the supervisory bell output.

When either zone 1, 2 or 4 is in alarm - outputs #1 (general alarm), #3 and #4 (solenoid release) will operate.  
 When zone 3 is in alarm - output #1 (general alarm) will operate.  
 When the supervisory zone is activated - output #2 (supervisory bell) will operate.

Wiring Diagram Program #4  
 Dual Hazard, Split-Release - 2 Alarm Zones, 1 Waterflow Zone,  
 and 2 Supervisory Zones

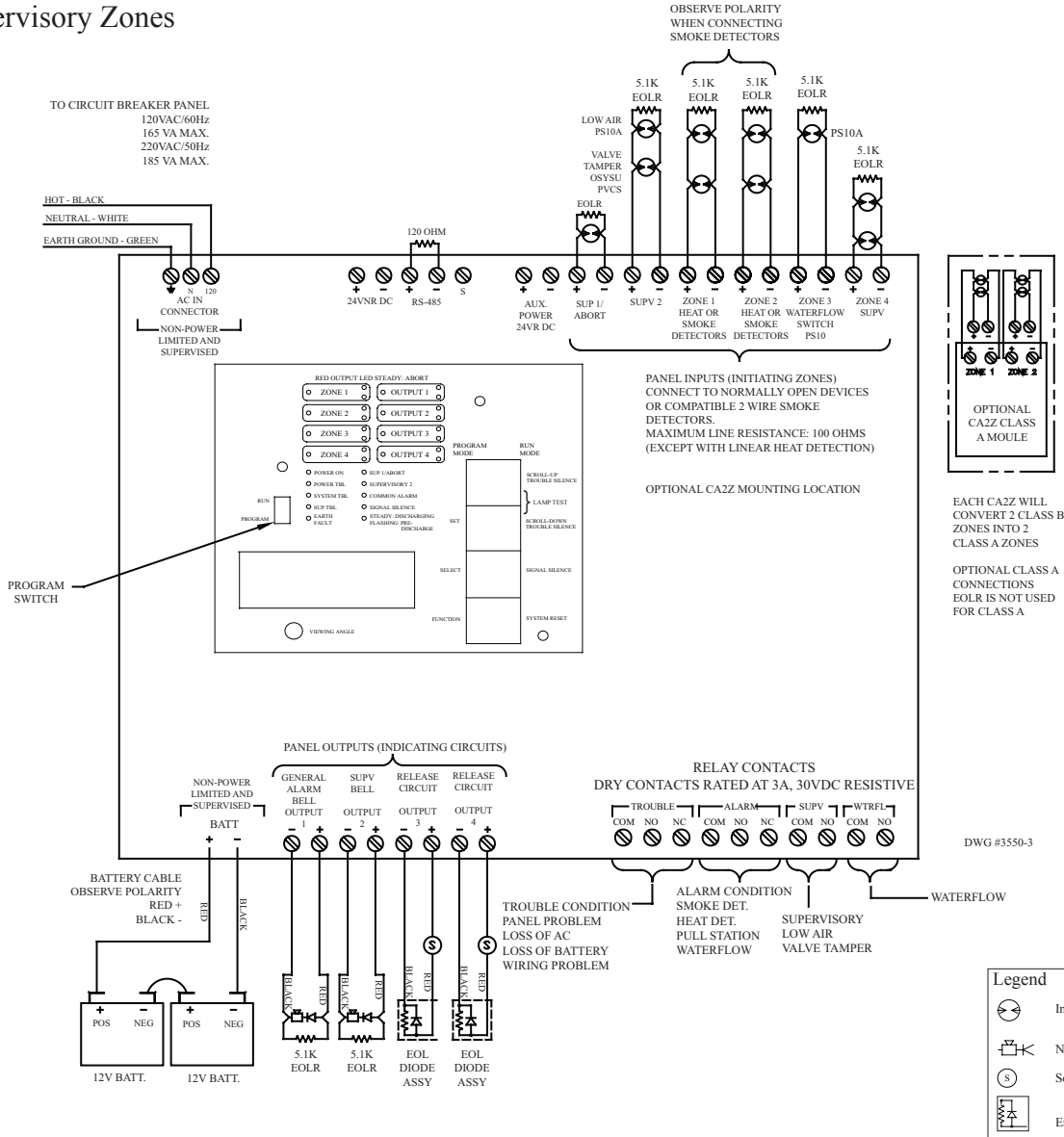

NOTES:

1. Connect only UL Listed 24VDC devices to indicating circuits.
  2. Connect EOL Diode assembly IN SERIES with solenoid on release circuit
  3. Leave EOLR (provided) on all unused circuits.
  4. Polarity is shown on indicating circuits in an activated (off-normal) condition.
  5. Polarity reverses when output is activated.
  6. Maximum current per output is 1 Amp. Maximum voltage is 33VDC.
  7. Outputs identified as Release are Special Application. All other outputs are Regulated 24 VDC, Rated 1 Amp each, 2.5 Amp total for all 4 circuits.
  8. All initiating and NAC/Release circuits are supervised and power limited. See note 3 on page 90 for power limited wire routing instructions. All frequencies are continuous.
  9. Refer to pgs. 16, 83-85 for installation, test and maintenance information.
  10. Maximum resistance on outputs is 10 ohms. Maximum resistance on outputs programmed as releasing, is 1 divided by current requirements of solenoid.
  11. Notification outputs do not provide synchronization. If synchronization is needed, refer to the NAC Compatibility Document, 5403592. Synchronization is only on one circuit and not between circuits. The maximum cannot exceed 1 amp or whatever the maximum that the sync' module can support, whichever is lower.
- See page 89 for smoke detector compatibility data.  
 See page 85 for battery information.

**Program #4 Mode**

1. Apply power to panel.
2. Move the program switch down.
3. Press the FUNCTION button until the display reads “PASSWORD = 000”.
4. To enter a password, press the SELECT button until the proper number is displayed above the ^ symbol, then press the SET button to move to the next digit. After entering the third number the display will change. (All panels are shipped with a 000 password.)
5. Press the FUNCTION button until the display reads “PROGRAM #0”.
6. Press the SELECT button until the display reads “PROGRAM #4”.
7. Press the SET button.
8. The panel is completely programmed except for the custom banner and zone messages. Move the program switch up.

PROGRAM #4						
	ZONES					
	SUP 1	SUP 2	#1	#2	#3	#4
OUTPUTS	Supervisory		Detection	Detection	Waterflow	Supervisory
#1 ALARM INDICATING			X	X	X	
#2 SUPERVISORY	X	X				X
#3 RELEASE			X			
#4 RELEASE				X		

Description: Dual hazard, split release.  
 Inputs: 2 detection zones, 1 waterflow zone, 3 supervisory zones  
 Outputs: 1 general alarm bell, 1 supervisory bell, 2 solenoid release circuits  
 Operation: Activation of detection zone #1 will operate solenoid release circuit #1 (output #3) and the general alarm bell.  
 Activation of detection zone #2 will operate solenoid release circuit #2 (output #4) and the general alarm bell.  
 Activation of zone #3 (Waterflow) will operate output #1 (General Alarm).  
 Activation of either supervisory zone will operate the supervisory bell.

When zone 1 is in alarm - output #1 (general alarm) and output #3 (solenoid release #1) will operate.  
 When zone 2 is in alarm - output #1 (general alarm) and output #4 (solenoid release #2) will operate.  
 When either zone 4 or the supervisory zones are activated - output #2 (supervisory bell) will operate.



Wiring Diagram Program #5  
 Single Hazard with Trouble Bell - 2 Alarm Zones, 1 Manual  
 Station Zone, 1 Waterflow Zone, and 2 Supervisory Zones

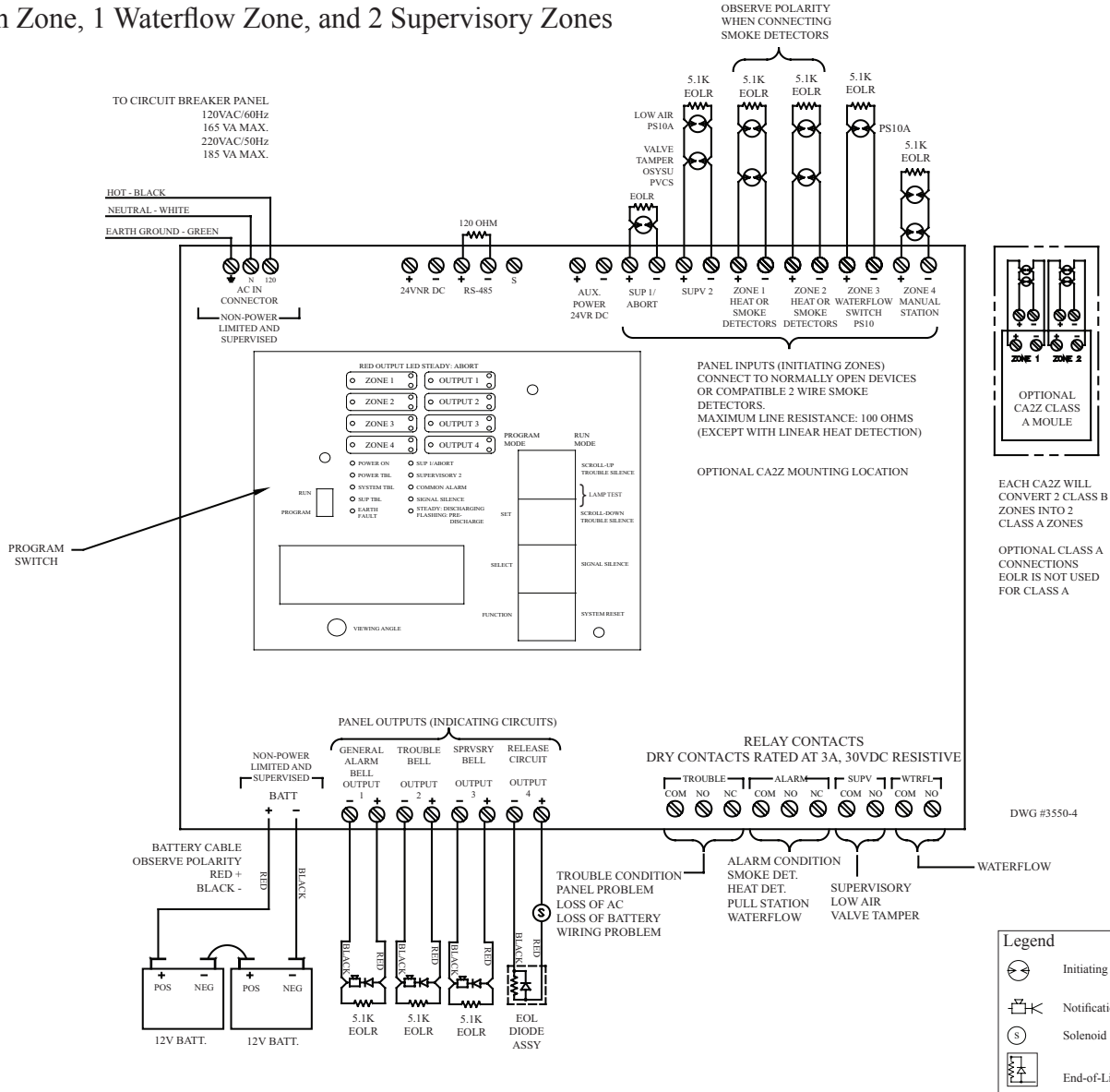

NOTES:

1. Connect only UL Listed 24VDC devices to indicating circuits.
  2. Connect EOL Diode assembly IN SERIES with solenoid on release circuit
  3. Leave EOLR (provided) on all unused circuits.
  4. Polarity is shown on indicating circuits in an activated (off-normal) condition.
  5. Polarity reverses when output is activated.
  6. Maximum current per output is 1 Amp. Maximum voltage is 33VDC.
  7. Outputs identified as Release are Special Application. All other outputs are Regulated 24 VDC, Rated 1 Amp each, 2.5 Amp total for all 4 circuits.
  8. All initiating and NAC/Release circuits are supervised and power limited. See note 3 on page 90 for power limited wire routing instructions. All frequencies are continuous.
  9. Refer to pgs. 16, 83-85 for installation, test and maintenance information.
  10. Maximum resistance on outputs is 10 ohms. Maximum resistance on outputs programmed as releasing, is 1 divided by current requirements of solenoid.
  11. Notification outputs do not provide synchronization. If synchronization is needed, refer to the NAC Compatibility Document, 5403592. Synchronization is only on one circuit and not between circuits. The maximum cannot exceed 1 amp or whatever the maximum that the sync' module can support, whichever is lower.
- See page 89 for smoke detector compatibility data.  
 See page 85 for battery information.

**Program #5 Mode**

1. Apply power to panel.
2. Move the program switch down.
3. Press the FUNCTION button until the display reads “PASSWORD = 000”.
4. To enter a password, press the SELECT button until the proper number is displayed above the ^ symbol, then press the SET button to move to the next digit. After entering the third number the display will change. (All panels are shipped with a 000 password.)
5. Press the FUNCTION button until the display reads “PROGRAM #0”.
6. Press the SELECT button until the display reads “PROGRAM #5”.
7. Press the SET button.
8. The panel is completely programmed except for the custom banner and zone messages. Move the program switch up.

PROGRAM #5						
	ZONES					
	SUP 1	SUP 2	#1	#2	#3	#4
OUTPUTS	Supervisory		Detection	Detection	Waterflow	Manual Release
#1 ALARM INDICATING			X	X	X	X
#2 TROUBLE						
#3 SUPERVISORY	X	X				
#4 RELEASE			X	X		X

Description: Single hazard, 3 zone with trouble bell.  
 Inputs: 2 detection zones, 1 waterflow zone, 1 manual release zone, 2 supervisory zones  
 Outputs: 1 general alarm bell, 1 trouble bell, 1 supervisory bell, 1 solenoid release circuit  
 Operation: Activation of either detection zone or the manual release zone will operate the solenoid release circuit and the general alarm bell.  
 Activation of the waterflow zone will operate the general alarm bell.  
 Activation of the supervisory zone will operate the supervisory bell.  
 A trouble condition (low battery, wire problem, etc.) will operate the trouble bell.

When either zone 1, 2 or 4 is in alarm - outputs #1 (general alarm) and #4 (solenoid release) will operate.  
 When zone 3 is in alarm - output #1 (general alarm) will operate.  
 When the supervisory zone is activated - output #3 (supervisory bell) will operate.  
 When the panel is in a trouble condition - output #2 (trouble bell) will operate.

Wiring Diagram Program #6  
 Single Hazard, 2 Alarm Zones with 1  
 Waterflow and 3 Supervisory Zones

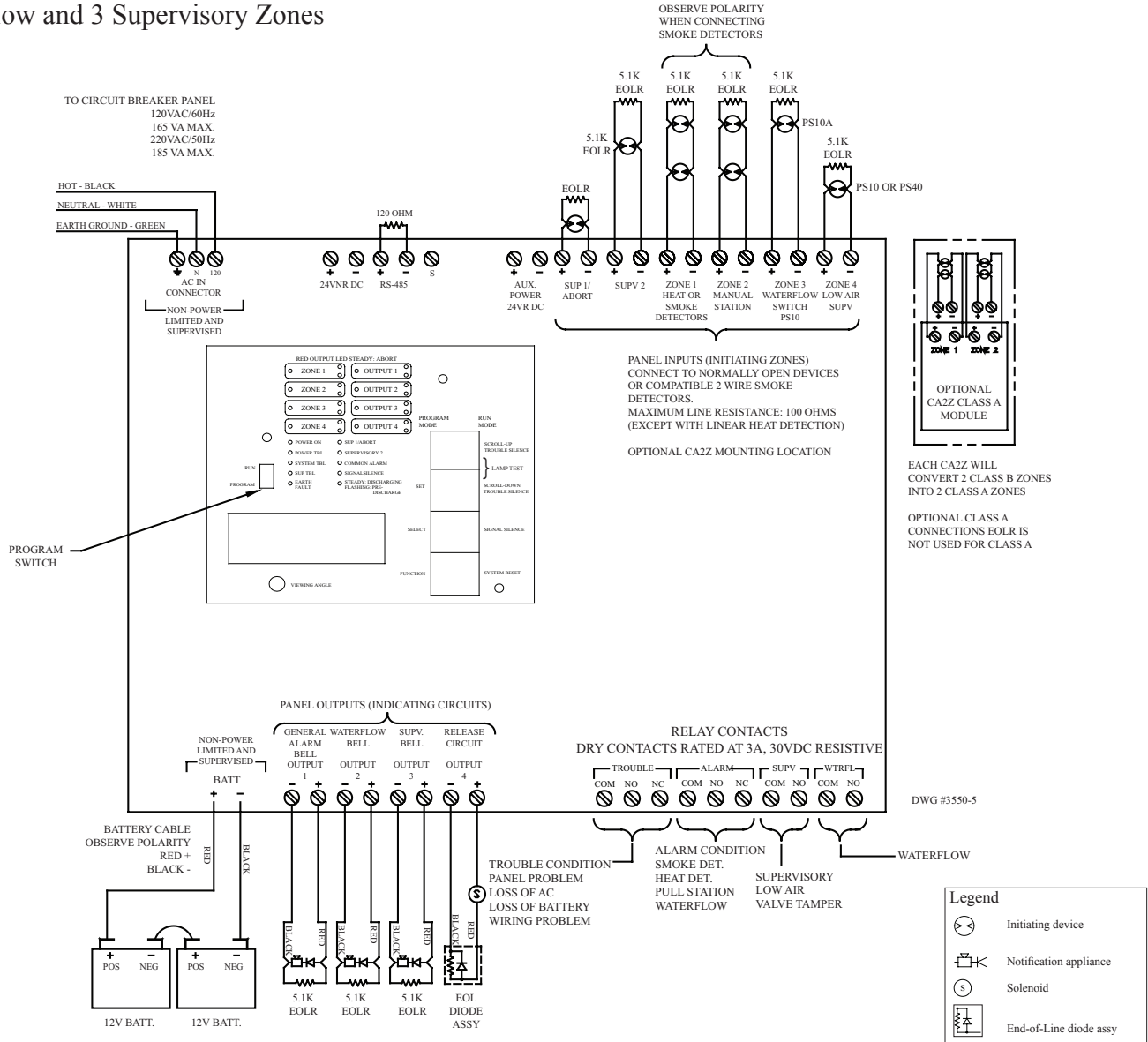

NOTES:

1. Connect only UL Listed 24VDC devices to indicating circuits.
  2. Connect EOL Diode assembly IN SERIES with solenoid on release circuit
  3. Leave EOLR (provided) on all unused circuits.
  4. Polarity is shown on indicating circuits in an activated (off-normal) condition.
  5. Polarity reverses when output is activated.
  6. Maximum current per output is 1 Amp. Maximum voltage is 33VDC.
  7. Outputs identified as Release are Special Application. All other outputs are Regulated 24 VDC, Rated 1 Amp each, 2.5 Amp total for all 4 circuits.
  8. All initiating and NAC/Release circuits are supervised and power limited. See note 3 on page 90 for power limited wire routing instructions. All frequencies are continuous.
  9. Refer to pgs. 16, 83-85 for installation, test and maintenance information.
  10. Maximum resistance on outputs is 10 ohms. Maximum resistance on outputs programmed as releasing, is 1 divided by current requirements of solenoid.
  11. Notification outputs do not provide synchronization. If synchronization is needed, refer to the NAC Compatibility Document, 5403592. Synchronization is only on one circuit and not between circuits. The maximum cannot exceed 1 amp or whatever the maximum that the sync' module can support, whichever is lower.
- See page 89 for smoke detector compatibility data.  
 See page 85 for battery information.

**Program #6 Mode**

1. Apply power to panel.
2. Move the program switch down.
3. Press the FUNCTION button until the display reads “PASSWORD = 000”.
4. To enter a password, press the SELECT button until the proper number is displayed above the ^ symbol, then press the SET button to move to the next digit. After entering the third number the display will change. (All panels are shipped with a 000 password.)
5. Press the FUNCTION button until the display reads “PROGRAM #0”.
6. Press the SELECT button until the display reads “PROGRAM #6”.
7. Press the SET button.
8. The panel is completely programmed except for the custom banner and zone messages. Move the program switch up.

PROGRAM #6						
	ZONES					
	SUP 1	SUP 2	#1	#2	#3	#4
OUTPUTS	Supervisory		Detection	Manual Release	Waterflow	Low Air Supervisory
#1 ALARM INDICATING			X	X		
#2 ALARM INDICATING					X	
#3 SUPERVISORY	X	X				X
#4 RELEASE			X	X		

Description: Single hazard, 2 zones and 2 supervisory zones.

Inputs: 1 detection zone, 1 manual release zone, 1 waterflow zone, 1 low air zone, 2 supervisory zones

Outputs: 1 general alarm bell, 1 waterflow bell, 1 supervisory bell, 1 solenoid release circuit

Operation: Activation of either the detection zone or the manual release zone will operate the solenoid release circuit and the general alarm bell.

Activation of the waterflow zone will operate the waterflow bell.

Activation of either the low air zone or the supervisory zone will operate the supervisory bell.

When either zone 1 or 2 is in alarm - output #1 (general alarm) and output #4 (solenoid release) will operate.

When zone 3 is in alarm - output #2 (waterflow bell) will operate.

When either zone 4 or the supervisory zone is activated - output #3 (supervisory bell) will operate.

# Wiring Diagram Program #7

## Single Hazard Cross-Zoned, 2 Alarm Zones, 1 Waterflow Zone and 3 Supervisory Zones

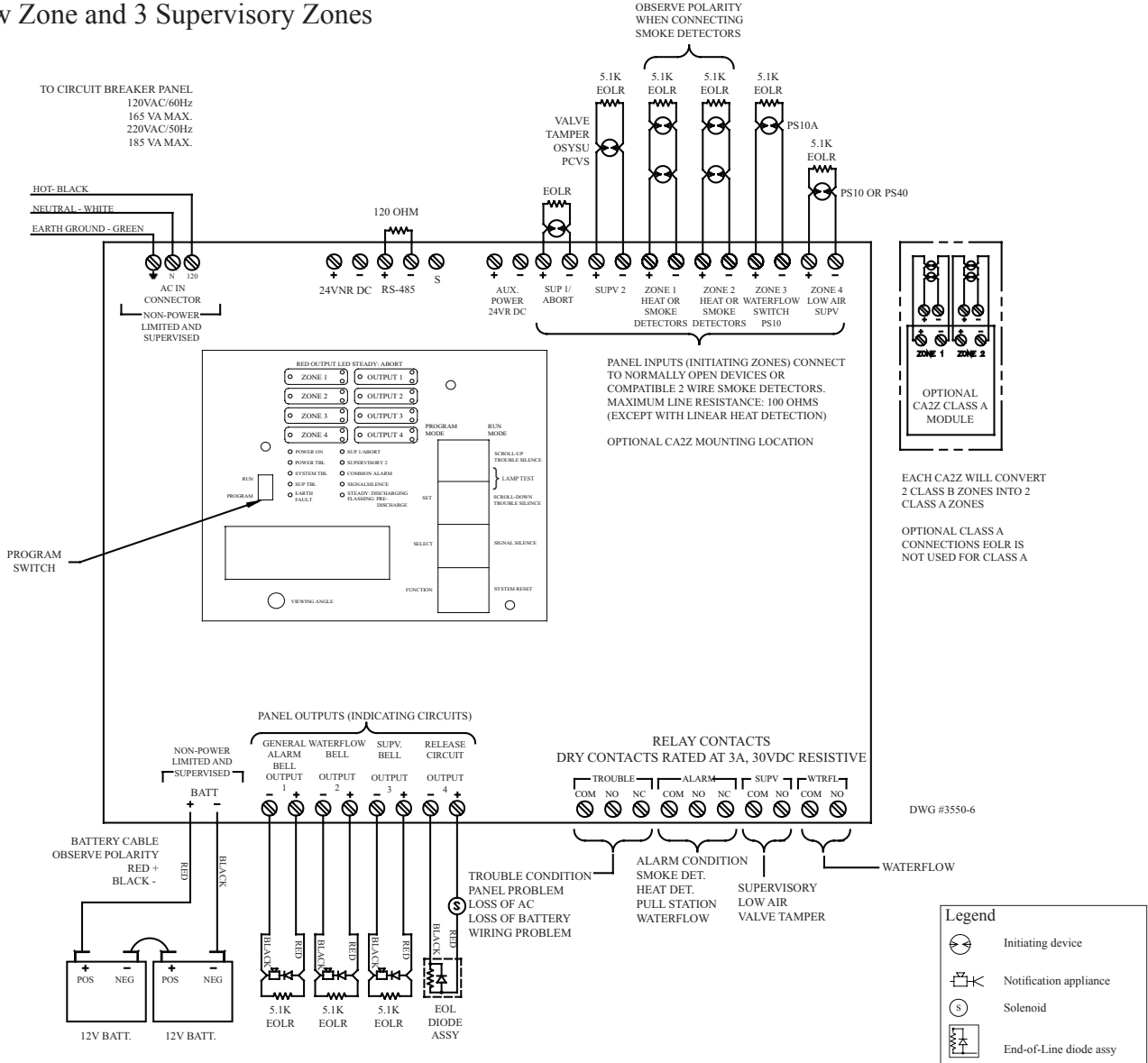

### NOTES:

1. Connect only UL Listed 24VDC devices to indicating circuits.
  2. Connect EOL Diode assembly IN SERIES with solenoid on release circuit
  3. Leave EOLR (provided) on all unused circuits.
  4. Polarity is shown on indicating circuits in an activated (off-normal) condition.
  5. Polarity reverses when output is activated.
  6. Maximum current per output is 1 Amp. Maximum voltage is 33VDC.
  7. Outputs identified as Release are Special Application. All other outputs are Regulated 24 VDC, Rated 1 Amp each, 2.5 Amp total for all 4 circuits.
  8. All initiating and NAC/Release circuits are supervised and power limited. See note 3 on page 90 for power limited wire routing instructions. All frequencies are continuous.
  9. Refer to pgs. 16, 83-85 for installation, test and maintenance information.
  10. Maximum resistance on outputs is 10 ohms. Maximum resistance on outputs programmed as releasing, is 1 divided by current requirements of solenoid.
  11. Notification outputs do not provide synchronization. If synchronization is needed, refer to the NAC Compatibility Document, 5403592. Synchronization is only on one circuit and not between circuits. The maximum cannot exceed 1 amp or whatever the maximum that the sync' module can support, whichever is lower.
- See page 89 for smoke detector compatibility data.
- See page 85 for battery information.

**Program #7 Mode**

1. Apply power to panel.
2. Move the program switch down.
3. Press the FUNCTION button until the display reads “PASSWORD = 000”.
4. To enter a password, press the SELECT button until the proper number is displayed above the ^ symbol, then press the SET button to move to the next digit. After entering the third number the display will change. (All panels are shipped with a 000 password.)
5. Press the FUNCTION button until the display reads “PROGRAM #0”.
6. Press the SELECT button until the display reads “PROGRAM #7”.
7. Press the SET button.
8. The panel is completely programmed except for the custom banner and zone messages. Move the program switch up.

PROGRAM #7						
	ZONES					
	SUP 1	SUP 2	#1	#2	#3	#4
OUTPUTS	Supervisory		Detection	Detection	Waterflow	Low Air Supervisory
#1 ALARM INDICATING			X	X		
#2 ALARM INDICATING					X	
#3 SUPERVISORY	X	X				X
#4 RELEASE			XX	XX		

XX = Cross-Zoned

- Description: Single hazard, 2 zones and cross zoned with 2 supervisory zones.  
 Inputs: 2 detection zones (cross zoned), 1 waterflow zone, 1 low air zone, 2 supervisory zones  
 Outputs: 1 general alarm bell, 1 waterflow bell, 1 supervisory bell, 1 solenoid release circuit  
 Operation: Activation of both detection zones at the same time will operate the solenoid release circuit and the general alarm bell.  
 Activation of either detection zone will operate the general alarm bell.  
 Activation of the waterflow zone will operate the waterflow bell.  
 Activation of either the low air zone or the supervisory zone will operate the supervisory bell.

- When either zone 1 or 2 is in alarm - output #1 (general alarm) will operate.
- When zones 1 and 2 are in alarm at the same time - output #4 (solenoid release) and output #1 (general alarm) will operate.
- When zone 3 is in alarm - output #2 (waterflow bell) will operate.
- When either zone 4 or the supervisory zone is activated - output #3 (supervisory bell) will operate.

# Wiring Diagram Program #8

## Single Hazard-Dual Zone, 2 Alarm Zones with 1 Waterflow Zone and 3 Supervisory Zones

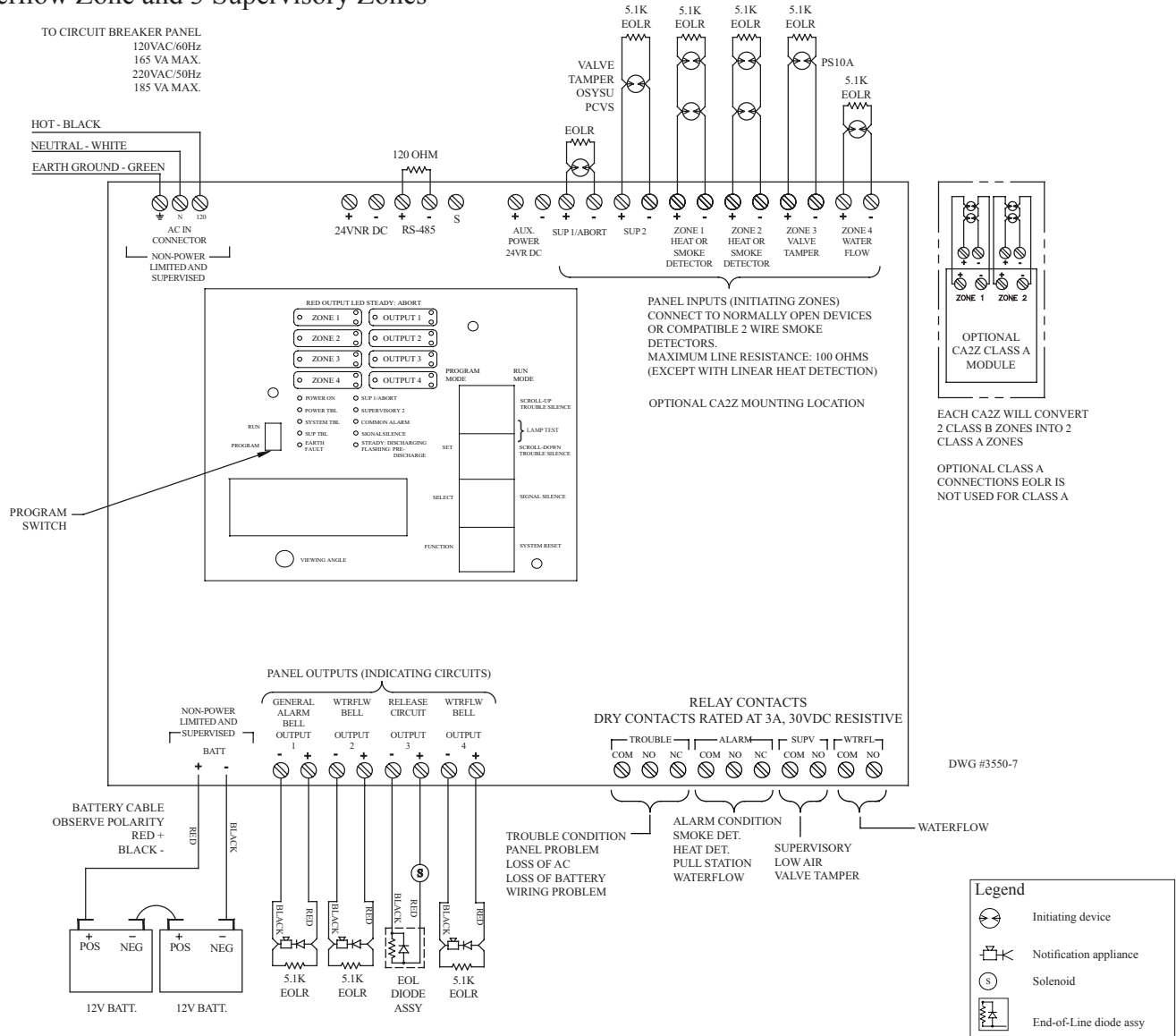

**NOTES:**

1. Connect only UL Listed 24VDC devices to indicating circuits.
2. Connect EOL Diode assembly IN SERIES with solenoid on release circuit
3. Leave EOLR (provided) on all unused circuits.
4. Polarity is shown on indicating circuits in an activated (off-normal) condition.
5. Polarity reverses when output is activated.
6. Maximum current per output is 1 Amp. Maximum voltage is 33VDC.
7. Outputs identified as Release are Special Application. All other outputs are Regulated 24 VDC, Rated 1 Amp each, 2.5 Amp total for all 4 circuits.
8. All initiating and NAC/Release circuits are supervised and power limited. See note 3 on page 90 for power limited wire routing instructions. All frequencies are continuous.
9. Refer to pgs. 16, 83-85 for installation, test and maintenance information.
10. Maximum resistance on outputs is 10 ohms. Maximum resistance on outputs programmed as releasing, is 1 divided by current requirements of solenoid.
11. Notification outputs do not provide synchronization. If synchronization is needed, refer to the NAC Compatibility Document, 5403592. Synchronization is only on one circuit and not between circuits. The maximum cannot exceed 1 amp or whatever the maximum that the sync' module can support, whichever is lower.

See page 89 for smoke detector compatibility data.

See page 85 for battery information.



**Program #8 Mode**

1. Apply power to panel.
2. Move the program switch down.
3. Press the FUNCTION button until the display reads “PASSWORD = 000”.
4. To enter a password, press the SELECT button until the proper number is displayed above the ^ symbol, then press the SET button to move to the next digit. After entering the third number the display will change. (All panels are shipped with a 000 password.)
5. Press the FUNCTION button until the display reads “PROGRAM #0”.
6. Press the SELECT button until the display reads “PROGRAM #8”.
7. Press the SET button.
8. The panel is completely programmed except for the custom banner and zone messages. Move the program switch up.

PROGRAM #8						
	ZONES					
	SUP 1	SUP 2	#1	#2	#3	#4
OUTPUTS	Supervisory	Low Air Supervisory	Detection	Detection	Valve Tamper	Waterflow
#1 ALARM INDICATING			X	X		X
#2 ALARM INDICATING						X
#3 RELEASE			X	X		
#4 ALARM						X

Description: Single hazard, dual zone.

Inputs: 1 supervisory zone, 1 low air supervisory zone, 2 detection zones, 1 tamper switch zone, 1 waterflow zone

Outputs: 1 general alarm output, 2 waterflow outputs, 1 solenoid release circuit

Operation: Activation of either detection zone will operate the general alarm bell and the solenoid release circuit.  
 Activation of the waterflow zone will operate the general alarm bell and both of the waterflow bell outputs.

When zone 1 or zone 2 is in alarm - output #1 (general alarm) and output #3 (solenoid release) will operate.

When either zone 3 or the supervisory zone is activated - the panel will be in a supervisory condition, no outputs will be activated.

When zone 4 is in alarm - output #1 (general alarm) and outputs #2 and #4 (both waterflow bells) will operate.

Wiring Diagram Program #9

Single Hazard Cross-Zoned, 1 Detection Zone with Low Air Alarm Zone, 1 Waterflow, 1 Low Air Supervisory, and 2 Supervisory Zones

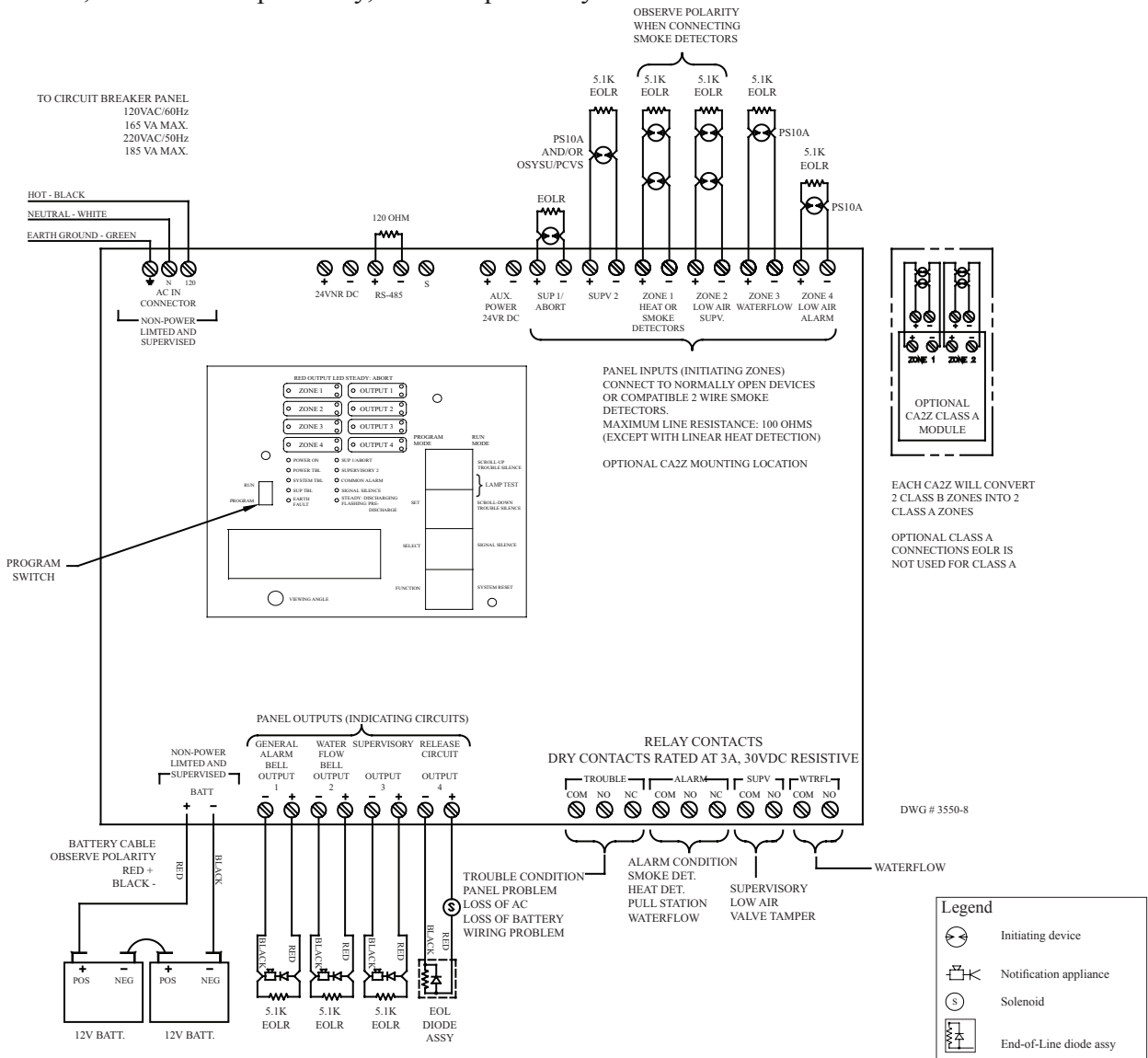

NOTES:

1. Connect only UL Listed 24VDC devices to indicating circuits.
  2. Connect EOL Diode assembly IN SERIES with solenoid on release circuit
  3. Leave EOLR (provided) on all unused circuits.
  4. Polarity is shown on indicating circuits in an activated (off-normal) condition.
  5. Polarity reverses when output is activated.
  6. Maximum current per output is 1 Amp. Maximum voltage is 33VDC.
  7. Outputs identified as Release are Special Application. All other outputs are Regulated 24 VDC, Rated 1 Amp each, 2.5 Amp total for all 4 circuits.
  8. All initiating and NAC/Release circuits are supervised and power limited. See note 3 on page 90 for power limited wire routing instructions. All frequencies are continuous.
  9. Refer to pgs. 16, 83-85 for installation, test and maintenance information.
  10. Maximum resistance on outputs is 10 ohms. Maximum resistance on outputs programmed as releasing, is 1 divided by current requirements of solenoid.
  11. Notification outputs do not provide synchronization. If synchronization is needed, refer to the NAC Compatibility Document, 5403592. Synchronization is only on one circuit and not between circuits. The maximum cannot exceed 1 amp or whatever the maximum that the sync' module can support, whichever is lower.
- See page 89 for smoke detector compatibility data.  
See page 85 for battery information.

**Program #9 Mode**

1. Apply power to panel.
2. Move the program down.
3. Press the FUNCTION button until the display reads “PASSWORD = 000”.
4. To enter a password, press the SELECT button until the proper number is displayed above the ^ symbol, then press the SET button to move to the next digit. After entering the third number the display will change.  
(All panels are shipped with a 000 password.)
5. Press the FUNCTION button until the display reads “PROGRAM #0”.
6. Press the SELECT button until the display reads “PROGRAM #9”.
7. Press the SET button.
8. The panel is completely programmed except for the custom banner and zone messages. Move the program switch up.

PROGRAM #9						
	ZONES					
	SUP 1	SUP 2	#1	#2	#3	#4
OUTPUTS	Supervisory		Detection	Low Air Supervisory	Waterflow	Low Air Alarm
#1 ALARM INDICATING			X			
#2 ALARM INDICATING					X	
#3 SUPERVISORY	X	X		X		X
#4 RELEASE			XX			XX

XX = Cross-Zoned

Description: Single Hazard, detection and low air alarm zones cross-zoned\*.  
 Inputs: 2 supervisory zones, 1 detection zone, 1 low air supervisory zone, 1 waterflow zone, 1 low air alarm zone.  
 Outputs: 1 general alarm, 1 supervisory, 1 waterflow, 1 solenoid release circuit  
 Operation: Activation of the detection zone and the low air alarm zone at the same time will operate the solenoid release circuit and the general alarm bell.  
 Activation of the detection zone only will operate the general alarm output  
 Activation of the low air supervisory zone will operate the supervisory bell output.  
 Activation of the waterflow zone will operate the waterflow bell output  
 Activation of the low air alarm zone will operate the supervisory bell output. It will not operate the alarm relay

When zone 1 is in alarm, output 1 will operate  
 When zone 2 is activated, output 3 will operate  
 When zone 3 is in alarm, output 2 will operate  
 When zone 4 is activated, output 3 will operate. This will create a supervisory condition not an alarm condition.  
 The alarm relay will not operate, the supervisory relay will.  
 When both zones 1 & 4 are activated at the same time, the solenoid release circuit will operate.

\*Cross Zoning acceptable for NFPA 13, 15, and 16 type extinguishing systems.

Wiring Diagram Program #10  
 Single Hazard Cross-Zoned, 2 Detection Zones with 1 Low  
 Air Alarm Zone 1 Waterflow Zone, and 2 Supervisory Zones

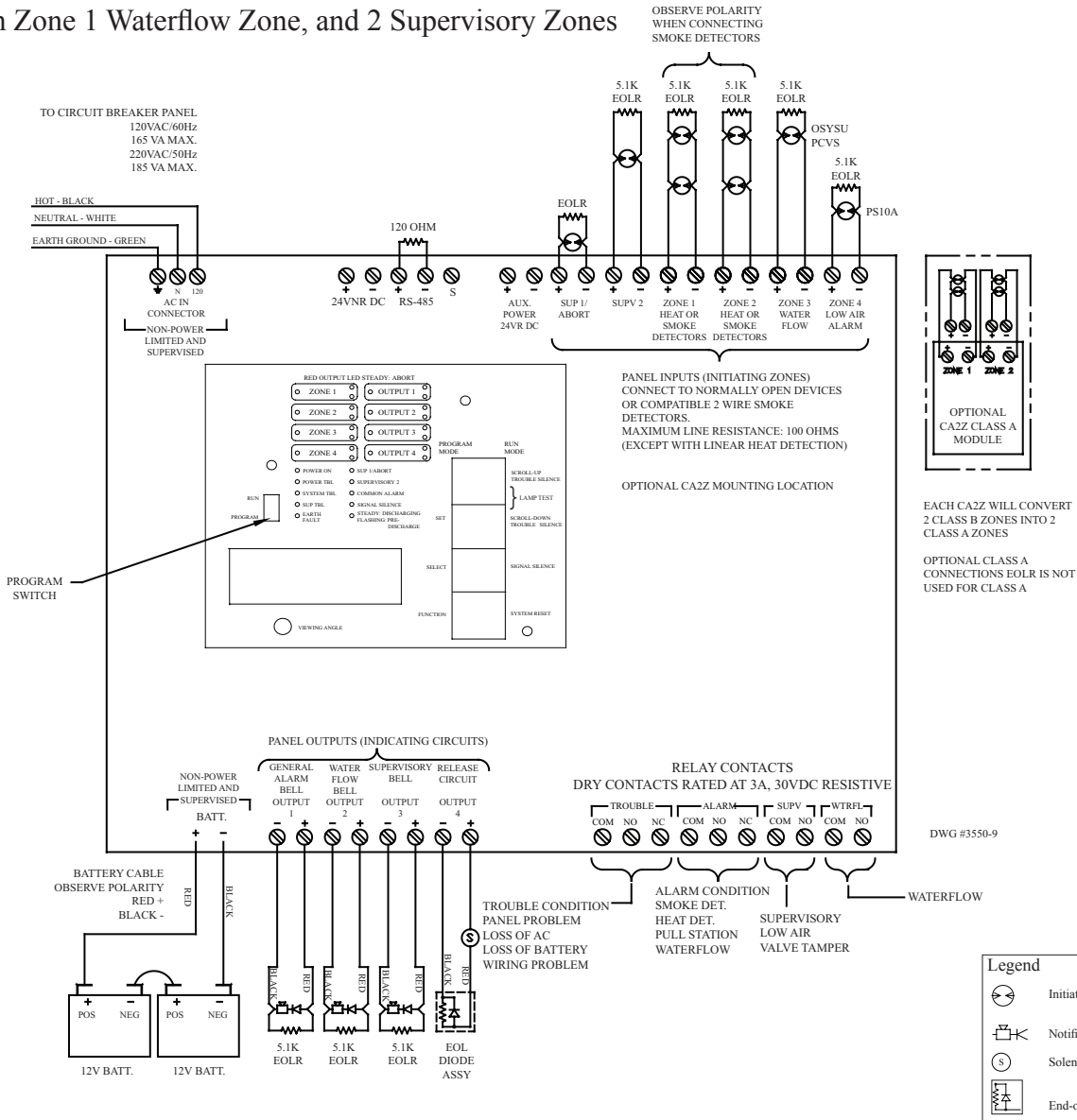

NOTES:

1. Connect only UL Listed 24VDC devices to indicating circuits.
2. Connect EOL Diode assembly IN SERIES with solenoid on release circuit
3. Leave EOLR (provided) on all unused circuits.
4. Polarity is shown on indicating circuits in an activated (off-normal) condition.
5. Polarity reverses when output is activated.
6. Maximum current per output is 1 Amp. Maximum voltage is 33VDC.
7. Outputs identified as Release are Special Application. All other outputs are Regulated 24 VDC, Rated 1 Amp each, 2.5 Amp total for all 4 circuits.
8. All initiating and NAC/Release circuits are supervised and power limited. See note 3 on page 90 for power limited wire routing instructions. All frequencies are continuous.
9. Refer to pgs. 16, 83-85 for installation, test and maintenance information.
10. Maximum resistance on outputs is 10 ohms. Maximum resistance on outputs programmed as releasing, is 1 divided by current requirements of solenoid.
11. Notification outputs do not provide synchronization. If synchronization is needed, refer to the NAC Compatibility Document, 5403592. Synchronization is only on one circuit and not between circuits. The maximum cannot exceed 1 amp or whatever the maximum that the sync' module can support, whichever is lower.

See page 89 for smoke detector compatibility data.

See page 85 for battery information.

**Program #10 Mode**

1. Apply power to panel.
2. Move the program down.
3. Press the FUNCTION button until the display reads “PASSWORD = 000”.
4. To enter a password, press the SELECT button until the proper number is displayed above the ^ symbol, then press the SET button to move to the next digit. After entering the third number the display will change.  
(All panels are shipped with a 000 password.)
5. Press the FUNCTION button until the display reads “PROGRAM #0”.
6. Press the SELECT button until the display reads “PROGRAM #10”.
7. Press the SET button.
8. The panel is completely programmed except for the custom banner and zone messages. Move the program switch back up.

PROGRAM #10						
	ZONES					
	SUP 1	SUP 2	#1	#2	#3	#4
OUTPUTS	Supervisory		Detection	Detection	Waterflow	Low Air Alarm
#1 ALARM INDICATING			X	X		
#2 ALARM INDICATING					X	
#3 SUPERVISORY	X	X				X
#4 RELEASE			XX	XX		XX

XX = Cross-Zoned

**Description:** Single Hazard, 2 detection and low air alarm zones cross-zoned\*.  
**Inputs:** 2 supervisory zones, 2 detection zone, 1 waterflow zone, 1 low air alarm zone.  
**Outputs:** 1 general alarm, 1 supervisory, 1 waterflow, 1 solenoid release circuit  
**Operation:** Activation of both detection zones and the low air alarm zone at the same time will operate the solenoid release circuit and the general alarm bell.  
 Activation of either detection zone only will operate the general alarm output  
 Activation of the waterflow zone will operate the waterflow bell output  
 Activation of the low air alarm zone will operate the supervisory bell output. It will not operate the alarm relay

When either zone 1 or 2 is in alarm, output 1 will operate  
 When zone 3 is in alarm, output 2 will operate  
 When zone 4 is activated, output 3 will operate. This will create a supervisory condition not an alarm condition.  
 The alarm relay will not operate, the supervisory relay will.  
 When zones 1, 2 & 4 are activated at the same time, the solenoid release circuit will operate.

\*Cross Zoning acceptable for NFPA 13, 15, and 16 type extinguishing systems.

Wiring Diagram Program #11  
 Single Hazard Cross-Zoned, 1 Detection Zone with Low Air Alarm  
 Zone 1 Waterflow, 1 Manual Release and 2 Supervisory Zones

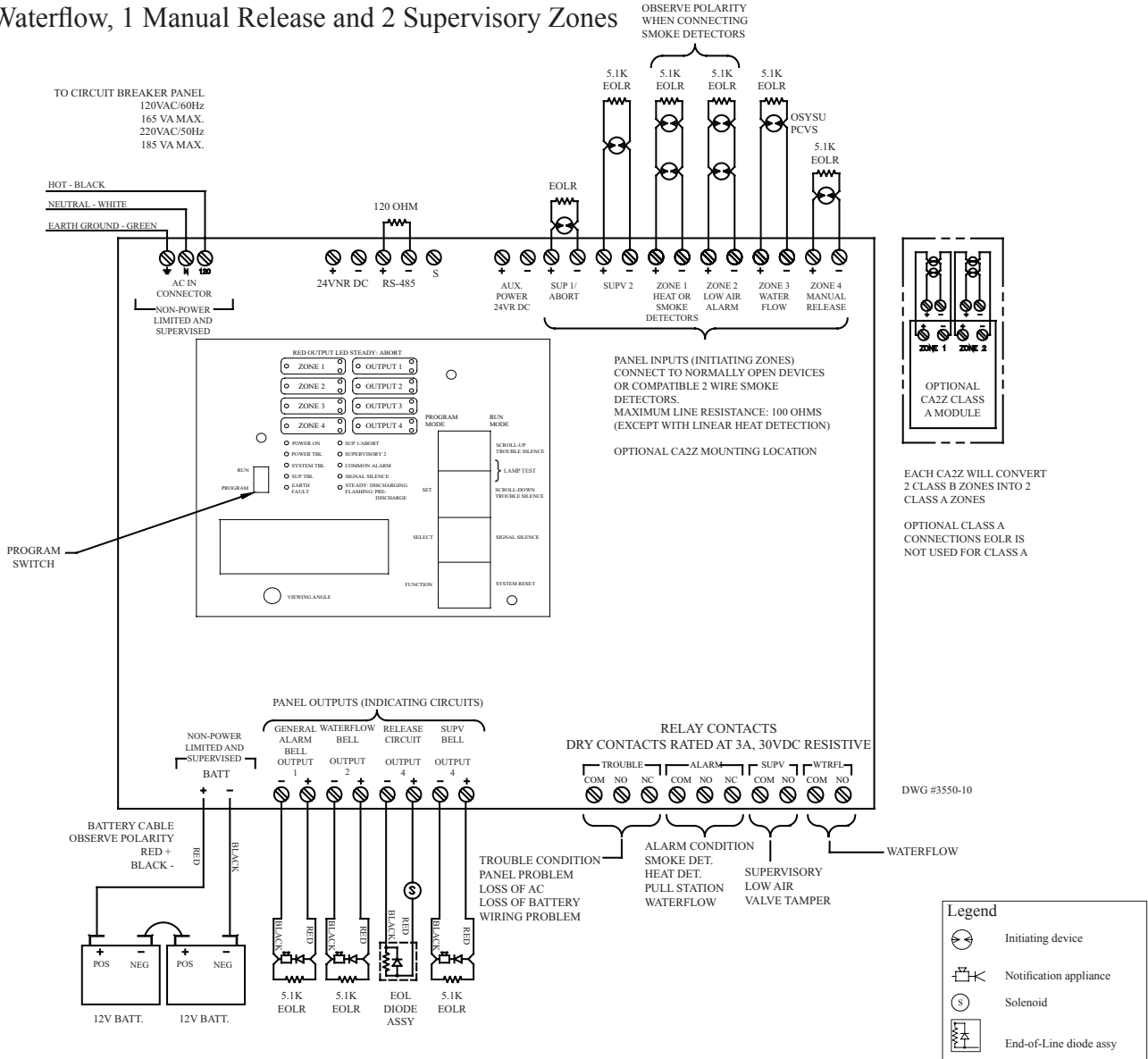

NOTES:

1. Connect only UL Listed 24VDC devices to indicating circuits.
  2. Connect EOL Diode assembly IN SERIES with solenoid on release circuit
  3. Leave EOLR (provided) on all unused circuits.
  4. Polarity is shown on indicating circuits in an activated (off-normal) condition.
  5. Polarity reverses when output is activated.
  6. Maximum current per output is 1 Amp. Maximum voltage is 33VDC.
  7. Outputs identified as Release are Special Application. All other outputs are Regulated 24 VDC, Rated 1 Amp each, 2.5 Amp total for all 4 circuits.
  8. All initiating and NAC/Release circuits are supervised and power limited. See note 3 on page 90 for power limited wire routing instructions. All frequencies are continuous.
  9. Refer to pgs. 16, 83-85 for installation, test and maintenance information.
  10. Maximum resistance on outputs is 10 ohms. Maximum resistance on outputs programmed as releasing, is 1 divided by current requirements of solenoid.
  11. Notification outputs do not provide synchronization. If synchronization is needed, refer to the NAC Compatibility Document, 5403592. Synchronization is only on one circuit and not between circuits. The maximum cannot exceed 1 amp or whatever the maximum that the sync' module can support, whichever is lower.
- See page 89 for smoke detector compatibility data.
- See page 85 for battery information.

**Program #11 Mode**

1. Apply power to panel.
2. Move the program switch down.
3. Press the FUNCTION button until the display reads “PASSWORD = 000”.
4. To enter a password, press the SELECT button until the proper number is displayed above the ^ symbol, then press the SET button to move to the next digit. After entering the third number the display will change.  
(All panels are shipped with a 000 password.)
5. Press the FUNCTION button until the display reads “PROGRAM #0”.
6. Press the SELECT button until the display reads “PROGRAM #11”.
7. Press the SET button.
8. The panel is completely programmed except for the custom banner and zone messages. Move the program switch back up.

PROGRAM #11						
	ZONES					
	SUP 1	SUP 2	#1	#2	#3	#4
OUTPUTS	Supervisory		Detection	Low Air Alarm	Waterflow	Manual Release
#1 ALARM INDICATING			X			X
#2 ALARM INDICATING					X	
#3 RELEASE			XX	XX		X
#4 SUPERVISORY	X	X		X		

XX = Cross-Zoned

**Description:** Single Hazard, detection and low air alarm zones cross-zoned\*. Also 1 waterflow and 1 manual release zone. Manual release overrides cross zoning.

**Inputs:** 2 supervisory zones, 1 detection zone, 1 low air alarm zone, 1 waterflow zone, 1 manual release zone.

**Outputs:** 1 general alarm, 1 supervisory, 1 waterflow, 1 solenoid release circuit

**Operation:** Activation of the detection zone and the low air alarm zone at the same time will operate the solenoid release circuit and the general alarm bell.  
Activation of the waterflow zone will operate the waterflow bell output  
Activation of the low air alarm zone will operate the supervisory bell output. It will not operate the alarm relay.

When zone 1 is in alarm, output 1 will operate  
 When zone 2 is activated, output 4 will operate. This will create a supervisory condition not an alarm condition. The alarm relay will not operate, the supervisory relay will.  
 When zone 3 is in alarm, output 2 will operate  
 When zone 4 is in alarm, outputs 1 & 3 will operate  
 When both zones 1 & 2 are activated at the same time, the solenoid release circuit, output 3, will operate.

\*Cross Zoning acceptable for NFPA 13, 15, and 16 type extinguishing systems.



Wiring Diagram Program #12  
 Single Hazard, 2 Detection Zones, 2  
 Supervisory Zones 1 Waterflow Zone

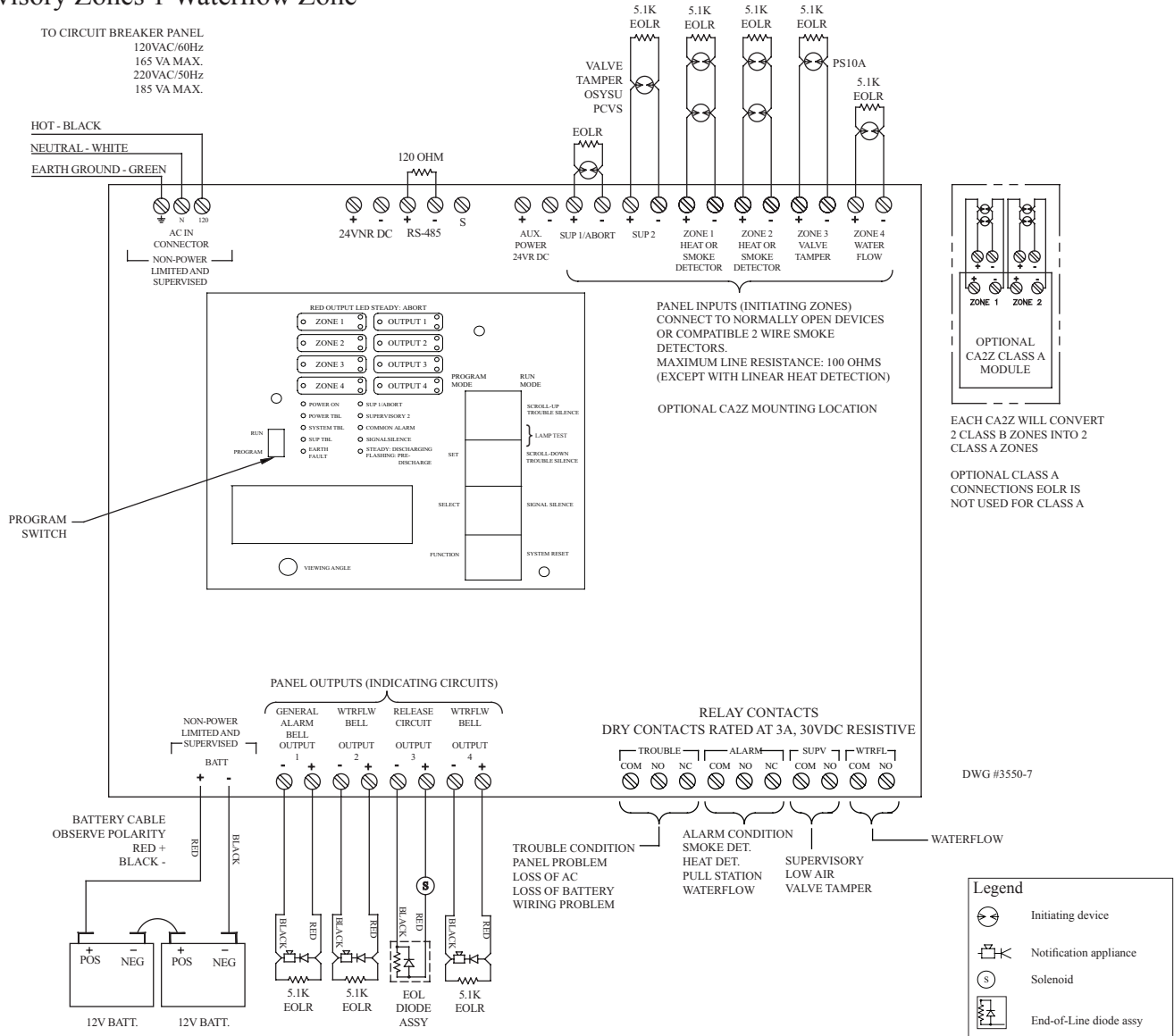

NOTES:

1. Connect only UL Listed 24VDC devices to indicating circuits.
  2. Connect EOL Diode assembly IN SERIES with solenoid on release circuit
  3. Leave EOLR (provided) on all unused circuits.
  4. Polarity is shown on indicating circuits in an activated (off-normal) condition.
  5. Polarity reverses when output is activated.
  6. Maximum current per output is 1 Amp. Maximum voltage is 33VDC.
  7. Outputs identified as Release are Special Application. All other outputs are Regulated 24 VDC, Rated 1 Amp each, 2.5 Amp total for all 4 circuits.
  8. All initiating and NAC/Release circuits are supervised and power limited. See note 3 on page 90 for power limited wire routing instructions. All frequencies are continuous.
  9. Refer to pgs. 16, 83-85 for installation, test and maintenance information.
  10. Maximum resistance on outputs is 10 ohms. Maximum resistance on outputs programmed as releasing, is 1 divided by current requirements of solenoid.
  11. Notification outputs do not provide synchronization. If synchronization is needed, refer to the NACCompatibility Document, 5403592. Synchronization is only on one circuit and not between circuits. The maximum cannot exceed 1 amp or whatever the maximum that the sync' module can support, whichever is lower.
- See page 89 for smoke detector compatibility data.
- See page 85 for battery information.

**Program #12 Mode**

1. Apply power to panel.
2. Move the program switch down.
3. Press the FUNCTION (button until the display reads “PASSWORD = 000”).
4. To enter a password, press the SELECT button until the proper number is displayed above the ^ symbol, then press the SET button to move to the next digit. After entering the third number the display will change.  
(All panels are shipped with a 000 password.)
5. Press the FUNCTION button until the display reads “PROGRAM #0”.
6. Press the SELECT button until the display reads “PROGRAM #12”.
7. Press the SET button.
8. The panel is completely programmed except for the custom banner and zone messages. Move the program switch back up.

PROGRAM #12						
OUTPUTS	ZONES					
	SUP 1	SUP 2	#1	#2	#3	#4
	Supervisory	Low Air Supervisory	Detection	Detection	Tamper	Waterflow
#1 ALARM INDICATING			X	X		X
#2 ALARM INDICATING						X
#3 RELEASE			X	X		
#4 ALARM INDICATING						X

Description: Single Hazard, 2 detection zones, 1 waterflow, and 3 supervisory zones.  
 Inputs: 1 supervisory zone, 1 low air supervisory zone, 2 detection zone, 1 waterflow zone, 1 tamper switch zone.  
 Outputs: 2 general alarm, 1 waterflow, 1 solenoid release circuit  
 Operation: Activation of either detection zone will operate the release and the general alarm bell outputs.  
 Activation of the waterflow zone will operate the waterflow and both general alarm bell outputs. Activation of either the tamper or supervisory zones will operate the supervisory relay only.

When either zone 1 or 2 is in alarm, outputs 1 & 3 will operate  
 When zone 3 or the supervisory zone is activated, only the supervisory relay operates  
 When zone 4 is in alarm, outputs 1, 2 & 4 will operate

Wiring Diagram Program #13  
 Single Hazard Cross-Zoned, 1 Detection Zone with Low Air Alarm Zone, 3 Supervisory Zones, and 1 Waterflow Zone

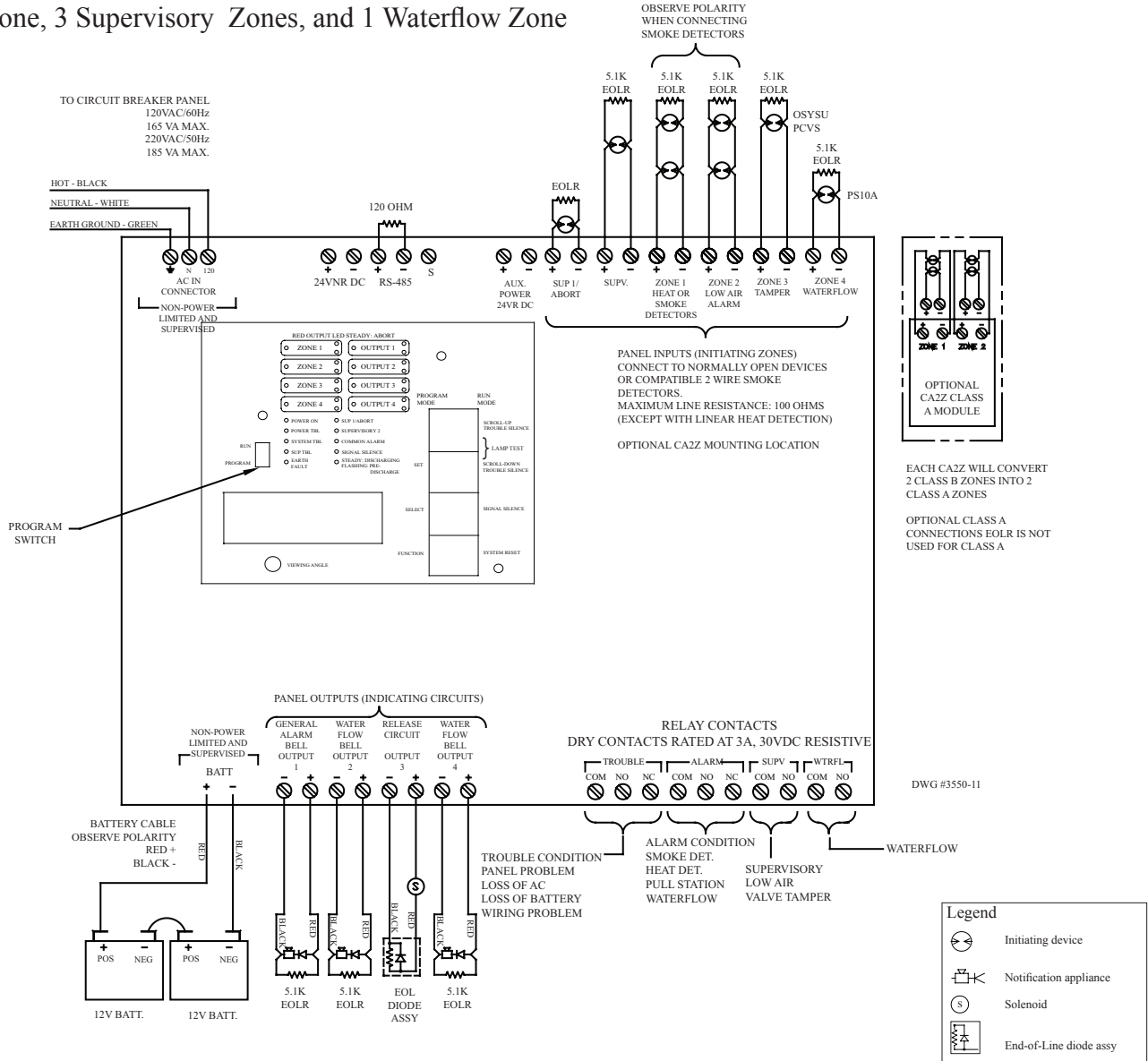

NOTES:

1. Connect only UL Listed 24VDC devices to indicating circuits.
2. Connect EOL Diode assembly IN SERIES with solenoid on release circuit
3. Leave EOLR (provided) on all unused circuits.
4. Polarity is shown on indicating circuits in an activated (off-normal) condition.
5. Polarity reverses when output is activated.
6. Maximum current per output is 1 Amp. Maximum voltage is 33VDC.
7. Outputs identified as Release are Special Application. All other outputs are Regulated 24 VDC, Rated 1 Amp each, 2.5 Amp total for all 4 circuits.
8. All initiating and NAC/Release circuits are supervised and power limited. See note 3 on page 90 for power limited wire routing instructions. All frequencies are continuous.
9. Refer to pgs. 16, 83-85 for installation, test and maintenance information.
10. Maximum resistance on outputs is 10 ohms. Maximum resistance on outputs programmed as releasing, is 1 divided by current requirements of solenoid.
11. Notification outputs do not provide synchronization. If synchronization is needed, refer to the NAC Compatibility Document, 5403592. Synchronization is only on one circuit and not between circuits. The maximum cannot exceed 1 amp or whatever the maximum that the sync' module can support, whichever is lower.

See page 89 for smoke detector compatibility data.

See page 85 for battery information.

**Program #13 Mode**

1. Apply power to panel.
2. Move the program switch down.
3. Press the FUNCTION button until the display reads “PASSWORD = 000”.
4. To enter a password, press the SELECT button until the proper number is displayed above the ^ symbol, then press the SET button to move to the next digit. After entering the third number the display will change.  
(All panels are shipped with a 000 password.)
5. Press the FUNCTION button until the display reads “PROGRAM #0”.
6. Press the SELECT button until the display reads “PROGRAM #13”.
7. Press the SET button.
8. The panel is completely programmed except for the custom banner and zone messages. Move the program switch back up.

PROGRAM #13						
	ZONES					
	SUP 1	SUP 2	#1	#2	#3	#4
OUTPUTS	Supervisory		Detection	Low Air Alarm	Tamper	Waterflow
#1 ALARM INDICATING			X			X
#2 ALARM INDICATING						X
#3 RELEASE			XX	XX		
#4 ALARM INDICATING						X

XX = Cross-Zoned

**Description:** Single Hazard, detection and low air alarm zones cross-zoned. Also 1 waterflow, 1 tamper and 1 supervisory zone

**Inputs:** 2 supervisory zones, 1 detection zone, 1 low air alarm zone, 1 tamper switch zone, 1 waterflow zone,

**Outputs:** 1 general alarm, 2 waterflow, 1 solenoid release circuit

**Operation:** Activation of the detection zone and the low air alarm zone at the same time will operate the solenoid release circuit and the general alarm bell.

Activation of the waterflow zone will operate both waterflow bell outputs

Activation of the low air alarm zone will not operate the alarm relay, only the supervisory relay.

When zone 1 is in alarm, output 1 will operate

When zone 2 is activated, it will create a supervisory condition not an alarm condition. The alarm relay will not operate, the supervisory relay will.

When zone 3 is activated, only the supervisory relay will operate.

When zone 4 is in alarm, outputs 1, 2 & 4 will operate.

When both zones 1 & 2 are activated at the same time, the solenoid release circuit, output 3, will operate.

\*Cross Zoning acceptable for NFPA 13, 15, and 16 type extinguishing systems.

Wiring Diagram Program #14

4 Alarm Zones and 4 Release Circuits mapped 1 to 1.

2 Supervisory Zones

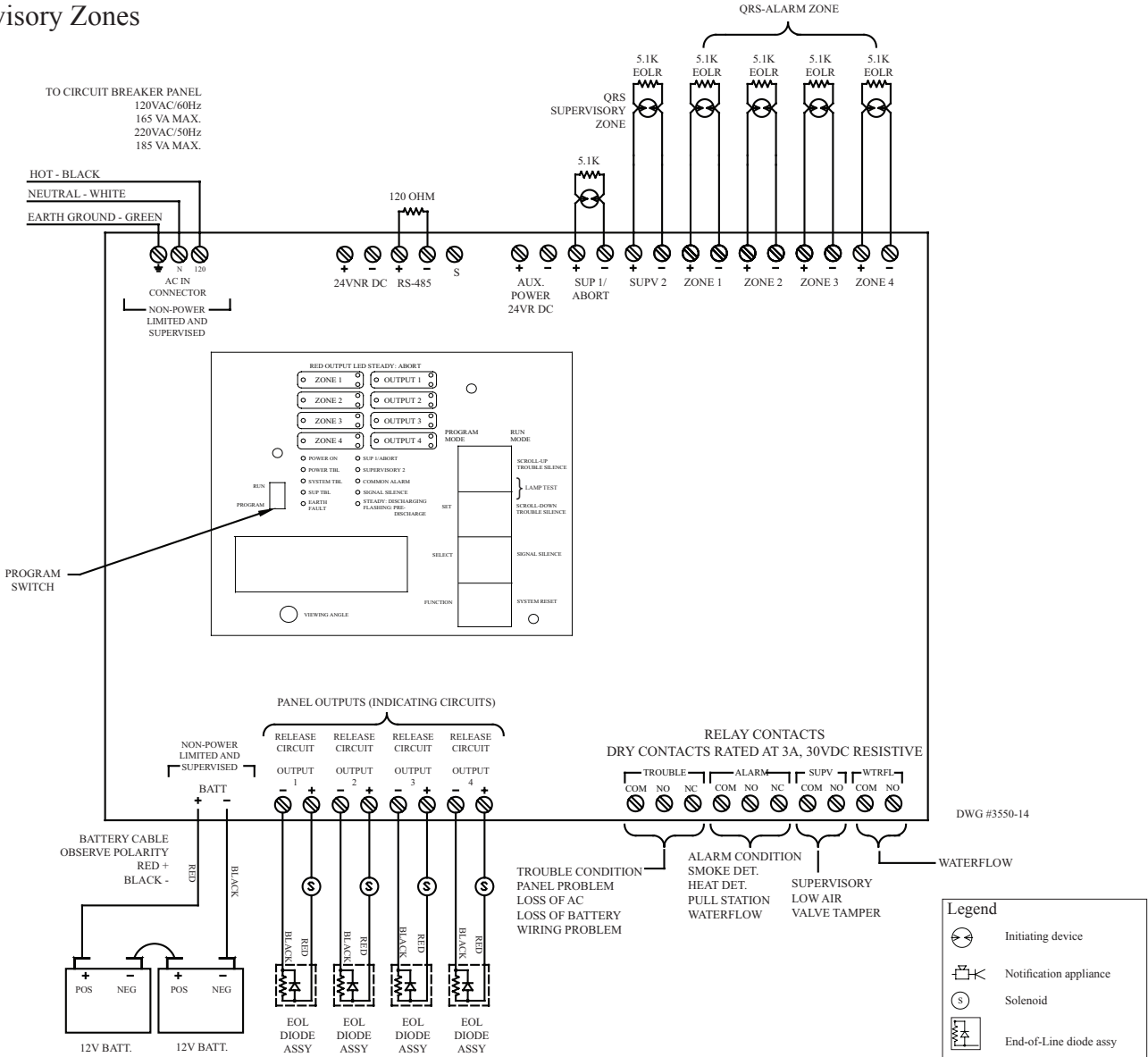

NOTES:

1. Connect only UL Listed 24VDC devices to indicating circuits.
2. Connect EOL Diode assembly IN SERIES with solenoid on release circuit
3. Leave EOLR (provided) on all unused circuits.
4. Polarity is shown on indicating circuits in an activated (off-normal) condition.
5. Polarity reverses when output is activated.
6. Maximum current per output is 1 Amp. Maximum voltage is 33VDC.
7. Outputs identified as Release are Special Application. All other outputs are Regulated 24 VDC, Rated 1 Amp each, 2.5 Amp total for all 4 circuits.
8. All initiating and NAC/Release circuits are supervised and power limited. See note 3 on page 90 for power limited wire routing instructions. All frequencies are continuous.
9. Refer to pgs. 16, 83-85 for installation, test and maintenance information.
10. Maximum resistance on outputs is 10 ohms. Maximum resistance on outputs programmed as releasing, is 1 divided by current requirements of solenoid.
11. Notification outputs do not provide synchronization. If synchronization is needed, refer to the NAC Compatibility Document, 5403592. Synchronization is only on one circuit and not between circuits. The maximum cannot exceed 1 amp or whatever the maximum that the sync' module can support, whichever is lower.

See page 89 for smoke detector compatibility data.

See page 85 for battery information.

**Program #14 Mode**

1. Apply power to panel.
2. Move the program switch down.
3. Press the FUNCTION button until the display reads “PASSWORD = 000”.
4. To enter a password, press the SELECT button until the proper number is displayed above the ^ symbol, then press the SET button to move to the next digit. After entering the third number the display will change.  
(All panels are shipped with a 000 password.)
5. Press the FUNCTION button until the display reads “PROGRAM #0”.
6. Press the SELECT button until the display reads “PROGRAM #14”.
7. Press the SET button.
8. The panel is completely programmed except for the custom banner and zone messages. Move the program switch back up.

PROGRAM #14						
	ZONES					
	SUP 1	SUP 2	#1	#2	#3	#4
OUTPUTS	Supervisory		Detection	Detection	Detection	Detection
#1 RELEASE			X			
#2 RELEASE				X		
#3 RELEASE					X	
#4 RELEASE						X

Description: QRS System 4 Manual Station zones and 4 Release Outputs mapped 1 to 1  
 Inputs: 4 Manual Station zones, 2 Supervisory zones  
 Outputs: 4 release circuits  
 Operation: Activation of detection zone 1 will activate release output #1  
 Activation of detection zone 2 will activate release output #2  
 Activation of detection zone 3 will activate release output #3  
 Activation of detection zone 4 will activate release output #4

**NOTE:**

After initially setting the PFC-4410RC to program 14 and returning the program switch to the normal UP position:  
 When setting or resetting the QRS, slide the program switch down. The display will read: OK TO CHARGE SYSTEM. Charge the system to normal operating pressure. After the system reaches normal operating pressure, press the SET button and slide the program switch back up.  
 Remember to wait 60 seconds after the system reaches normal operating pressure before testing the QRS.

 <b>CAUTION</b>
<b>WHEN THE PROGRAM SWITCH IS IN THE DOWN POSITION, THE PANEL IS INOPERATIVE. NONE OF THE OUTPUTS OR INPUTS WILL OPERATE. NO QRS WILL OPERATE. THE SPRINKLER SYSTEM WILL OPERATE AS A REGULAR DRY PIPE SYSTEM.</b>

Wiring Diagram Program #15

Dual Hazard, 1 Detection Zone and 1 Low Air Alarm Zone Cross-Zoned to 1 Release Circuit, 1 Other Detection and 1 other Low Air Alarm Zone Cross-Zoned to a Separate Release Circuit, and Supervisory Zones.

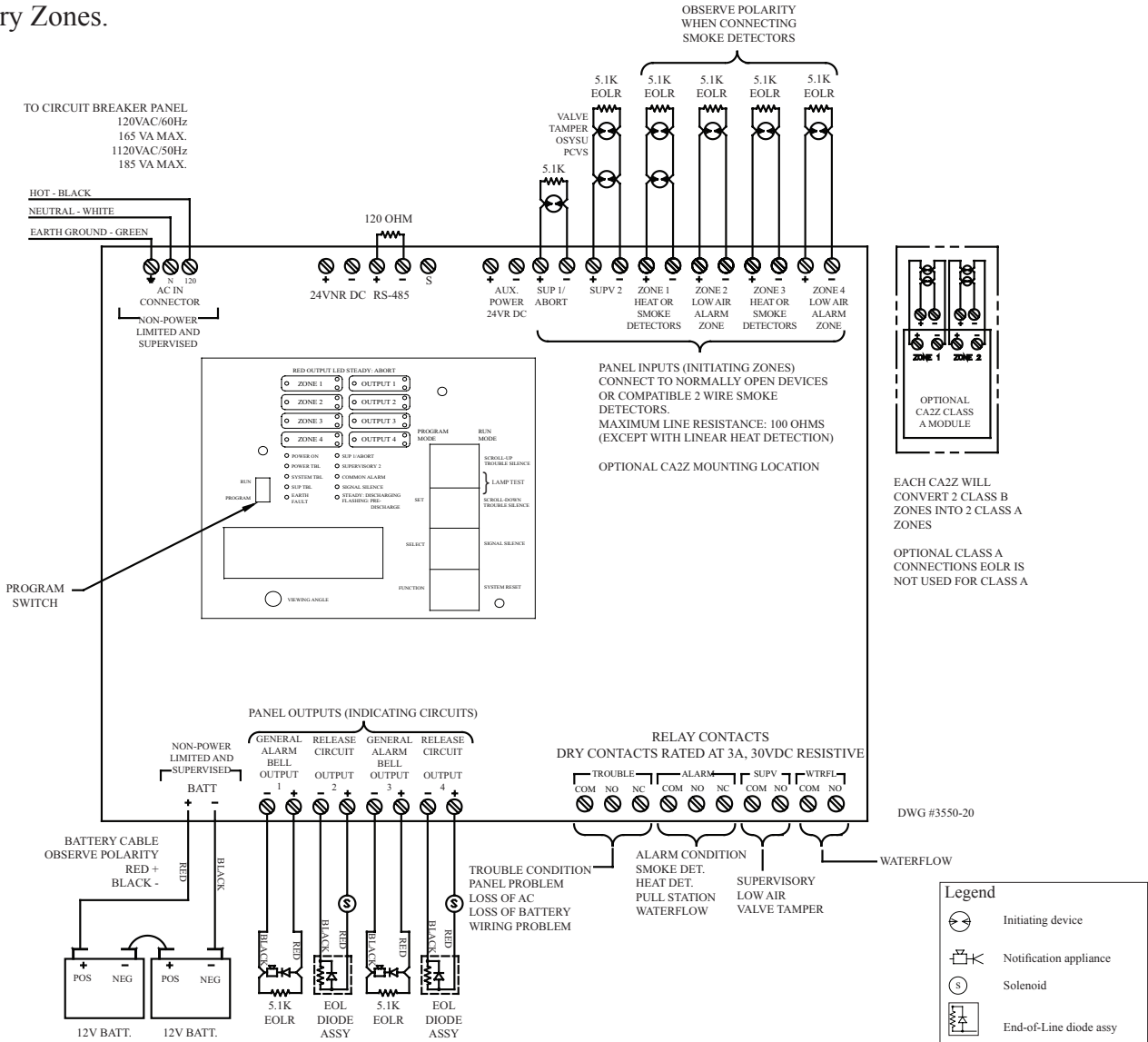

NOTES:

1. Connect only UL Listed 24VDC devices to indicating circuits.
2. Connect EOL Diode assembly IN SERIES with solenoid on release circuit
3. Leave EOLR (provided) on all unused circuits.
4. Polarity is shown on indicating circuits in an activated (off-normal) condition.
5. Polarity reverses when output is activated.
6. Maximum current per output is 1 Amp. Maximum voltage is 33VDC.
7. Outputs identified as Release are Special Application. All other outputs are Regulated 24 VDC, Rated 1 Amp each, 2.5 Amp total for all 4 circuits.
8. All initiating and NAC/Release circuits are supervised and power limited. See note 3 on page 90 for power limited wire routing instructions. All frequencies are continuous.
9. Refer to pgs. 16, 83-85 for installation, test and maintenance information.
10. Maximum resistance on outputs is 10 ohms. Maximum resistance on outputs programmed as releasing, is 1 divided by current requirements of solenoid.
11. Notification outputs do not provide synchronization. If synchronization is needed, refer to the NAC Compatibility Document, 5403592. Synchronization is only on one circuit and not between circuits. The maximum cannot exceed 1 amp or whatever the maximum that the sync' module can support, whichever is lower.

See page 89 for smoke detector compatibility data.

See page 85 for battery information.



**Program #15 Mode**

1. Apply power to panel.
2. Move the program switch down.
3. Press the FUNCTION button until the display reads “PASSWORD = 000”.
4. To enter a password, press the SELECT button until the proper number is displayed above the ^ symbol, then press the SET button to move to the next digit. After entering the third number the display will change.  
(All panels are shipped with a 000 password.)
5. Press the FUNCTION button until the display reads “PROGRAM #0”.
6. Press the SELECT button until the display reads “PROGRAM #15”.
7. Press the SET button.
8. The panel is completely programmed except for the custom banner and zone messages Move the program switch back up.

PROGRAM #15						
	ZONES					
	SUP 1	SUP 2	#1	#2	#3	#4
OUTPUTS	Supervisory		Detection	Low Air Alarm	Detection	Low Air Alarm
#1 ALARM INDICATING			X	X		
#2 RELEASE			XX	XX		
#3 ALARM INDICATING					X	X
#4 RELEASE					XX	XX

XX = Cross-Zoned

Description: Dual Hazard, 2 detection zones cross-zoned\* to 1 release circuit and 2 other detection zones cross zoned to another release circuit

Inputs: 2 supervisory zones, 4 detection zones

Outputs: 2 general alarm, 2 release circuit

Operation: Activation of either detection zones 1 and 2 will activate the alarm output #1  
 Activation of both detection circuits at the same time will release circuit output #2 as well as activate the alarm output #1  
 Activation of either detection zones 3 and 4 will activate the alarm output #3  
 Activation of both detection circuits at the same time will release circuit output #4 as well as activate the alarm output #3

When either zone 1 or 2 is in alarm, output 1 will operate  
 When both zones 1 and 2 are in alarm at the same time, output #2 will operate  
 When either zone 3 or 4 is in alarm, output 3 will operate  
 When both zones 3 and 4 are in alarm at the same time, output #4 will operate

\*Cross Zoning acceptable for NFPA 13, 15, and 16 type extinguishing systems.

**NOTICE**

The following programs are for chemical or gas extinguishing systems. Selecting the CHEMICAL mode allows the use of a pre-discharge timer and an abort circuit. The timer defaults to 60 seconds for all alarm zones programmed as other than MANUAL RELEASE. The MANUAL RELEASE default timer is 30 seconds. The system offers the programmer the ability to change the default timers to shorter times.

Systems intended for the release of Halon 1301 as described in NFPA 12A, or clean agents as described in NFPA 2001, shall have provision for a pre-discharge notification circuit. If this signal is required to be separate and/or distinct from the evacuation signal, two notification circuits are required. One shall be programmed as FIRST ALARM. It will provide a steady output upon activation of any initiating zone programmed as an alarm zone. This is the evacuation signal. If a temporal signal is required, notification appliances such as Potter model EH24 or others that can produce a temporal tone shall be used. This allows the use of strobes and horns on the same circuit. The other notification circuit shall be programmed as SECOND ALARM. It will provide a steady output upon activation of a second initiating zone programmed as an alarm zone. This is when the pre-discharge timer would start and would be the pre-discharge signal. If a temporal signal is required, notification appliances such as Potter model EH24 or others that can produce a temporal tone shall be used. This allows the use of strobes and horns on the same circuit. If a separate signal for discharge were required, a third notification circuit would be used that would be programmed to operate whenever the release circuit is activated.

Zones programmed as MANUAL RELEASE will activate outputs programmed as SECOND ALARM, even if the MANUAL RELEASE zone is the first alarm zone activated. SECOND ALARM is intended to be used as a pre-discharge signal for cross zone applications. Refer to page 79 for a complete description of first and second alarm requirements and operation.

**CAUTION**

**ZONES PROGRAMMED AS MANUAL RELEASE CANNOT BE ABORTED. IF IT IS NECESSARY TO ABORT A MANUAL RELEASE ZONE, THAT ZONE MUST BE PROGRAMMED AS DETECTION. IF THE PRE-DISCHARGE TIMER IS SET AT 0, THE ABORT CIRCUIT WILL NOT STOP THE RELEASE.**

NFPA 12 prohibits the use of abort circuits on suppression systems deploying carbon dioxide.

Systems designed and installed in accordance with NFPA 2001 shall be provided with a mechanical manual release system.

*NOTE:*

On programs 20-28, the SUP 1/Abort zone defaults to Abort.

**THIS PAGE INTENTIONALLY LEFT BLANK.**

Wiring Diagram Program #20

Dual Hazard, 2 Detection Zones Cross-Zoned to 1 Release Circuit, 2 Other Detection Zones Cross-Zoned to A Separate Release Circuit, 1 Supervisory Zone, 1 Abort Circuit

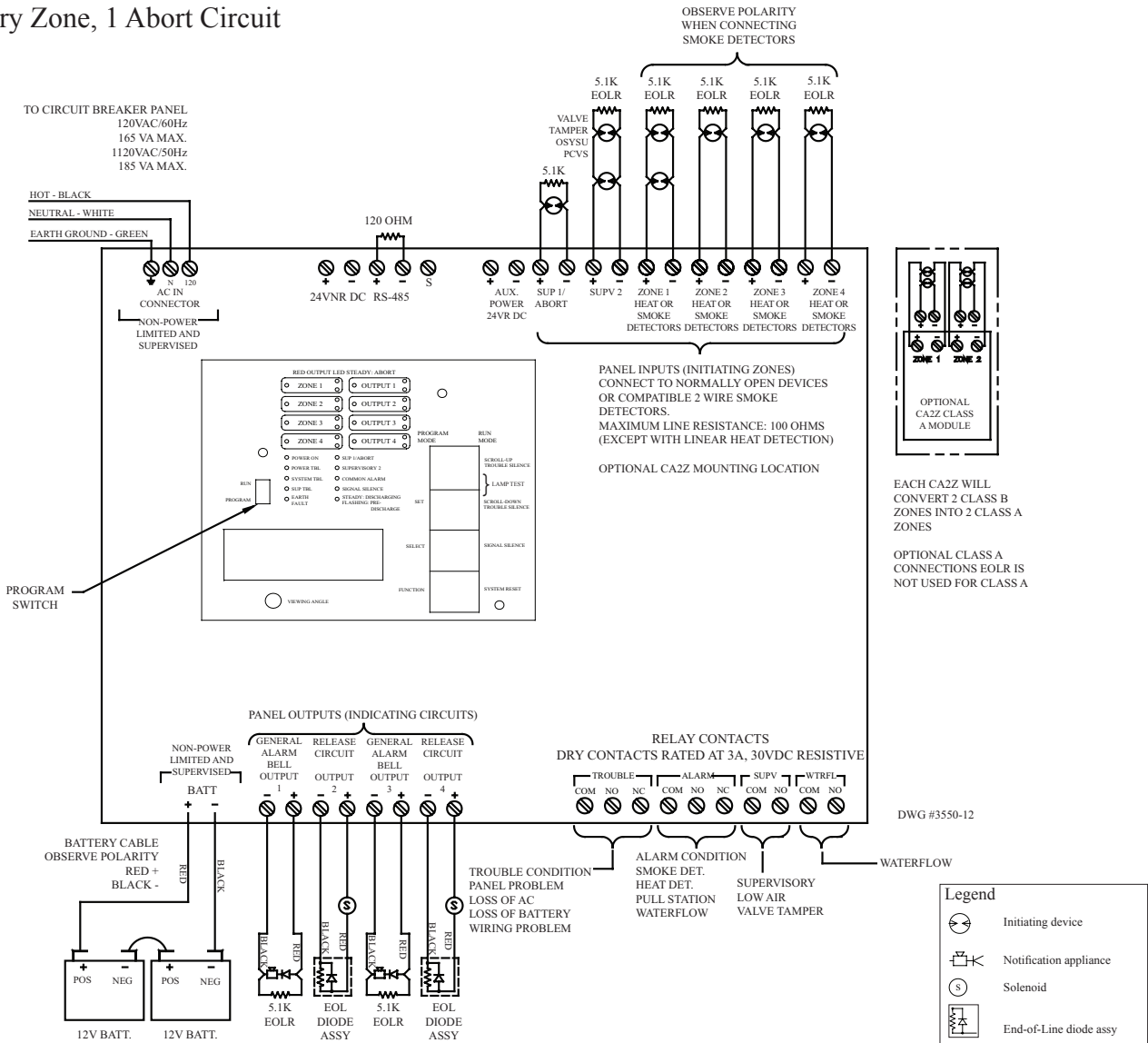

NOTES:

1. Connect only UL Listed 24VDC devices to indicating circuits.
  2. Connect EOL Diode assembly IN SERIES with solenoid on release circuit
  3. Leave EOLR (provided) on all unused circuits.
  4. Polarity is shown on indicating circuits in an activated (off-normal) condition.
  5. Polarity reverses when output is activated.
  6. Maximum current per output is 1 Amp. Maximum voltage is 33VDC.
  7. Outputs identified as Release are Special Application. All other outputs are Regulated 24 VDC, Rated 1 Amp each, 2.5 Amp total for all 4 circuits.
  8. All initiating and NAC/Release circuits are supervised and power limited. See note 3 on page 90 for power limited wire routing instructions. All frequencies are continuous.
  9. Refer to pgs. 16, 83-85 for installation, test and maintenance information.
  10. Maximum resistance on outputs is 10 ohms. Maximum resistance on outputs programmed as releasing, is 1 divided by current requirements of solenoid.
  11. Notification outputs do not provide synchronization. If synchronization is needed, refer to the NAC Compatibility Document, 5403592. Synchronization is only on one circuit and not between circuits. The maximum cannot exceed 1 amp or whatever the maximum that the sync' module can support, whichever is lower.
- See page 89 for smoke detector compatibility data.  
See page 85 for battery information.

**Program #20 Mode**

1. Apply power to panel.
2. Move the program switch down.
3. Press the FUNCTION button until the display reads “PASSWORD = 000”.
4. To enter a password, press the SELECT button until the proper number is displayed above the ^ symbol, then press the SET button to move to the next digit. After entering the third number the display will change.  
(All panels are shipped with a 000 password.)
5. Press the FUNCTION button until the display reads “PROGRAM #0”.
6. Press the SELECT button until the display reads “PROGRAM #20”.
7. Press the SET button.
8. Press the SELECT button to change the pre-discharge time.
9. Press the SET button to enter the pre-discharge time displayed.
10. Press the SELECT button to change the abort mode. See page 11 for abort mode selections.
11. Press the SET button to enter the abort mode displayed.
12. The panel is completely programmed except for the custom banner and zone messages. Move the program switch back up.

PROGRAM #20					
	ZONES				
	SUPERVISORY 2	#1	#2	#3	#4
OUTPUTS	Supervisory	Detection	Detection	Detection	Detection
#1 ALARM INDICATING		X	X		
#2 RELEASE		XX	XX		
#3 ALARM INDICATING				X	X
#4 RELEASE				XX	XX

SUP 1 defaults to abort  
XX = Cross-Zoned

**Description:** Dual Hazard, 2 detection zones cross-zoned to 1 release circuit and 2 other detection zones cross zoned to another release circuit

**Inputs:** 1 supervisory zone, 4 detection zones, 1 abort circuit

**Outputs:** 2 general alarm, 2 release circuit

**Operation:** Activation of either detection zones 1 and 2 will activate the alarm output #1  
Activation of both detection circuits at the same time will start the pre-discharge timer for release circuit output #2 as well as activate the alarm output #1  
Activation of either detection zones 3 and 4 will activate the alarm output #3  
Activation of both detection circuits at the same time will start the pre-discharge timer for release circuit output #4 as well as activate the alarm output #3

When either zone 1 or 2 is in alarm, output 1 will operate  
When both zones 1 and 2 are in alarm at the same time, the pre-discharge timer for output #2 will operate  
When either zone 3 or 4 is in alarm, output 3 will operate  
When both zones 3 and 4 are in alarm at the same time, the pre-discharge timer for output #4 will operate

### Wiring Diagram Program #21

Dual Hazard, 2 Detection Zones Mapped to 1 Release Circuit and 2 Other Detection Zones Mapped to A Separate Circuit, 1 Abort Circuit, and 1 Supervisory Circuit

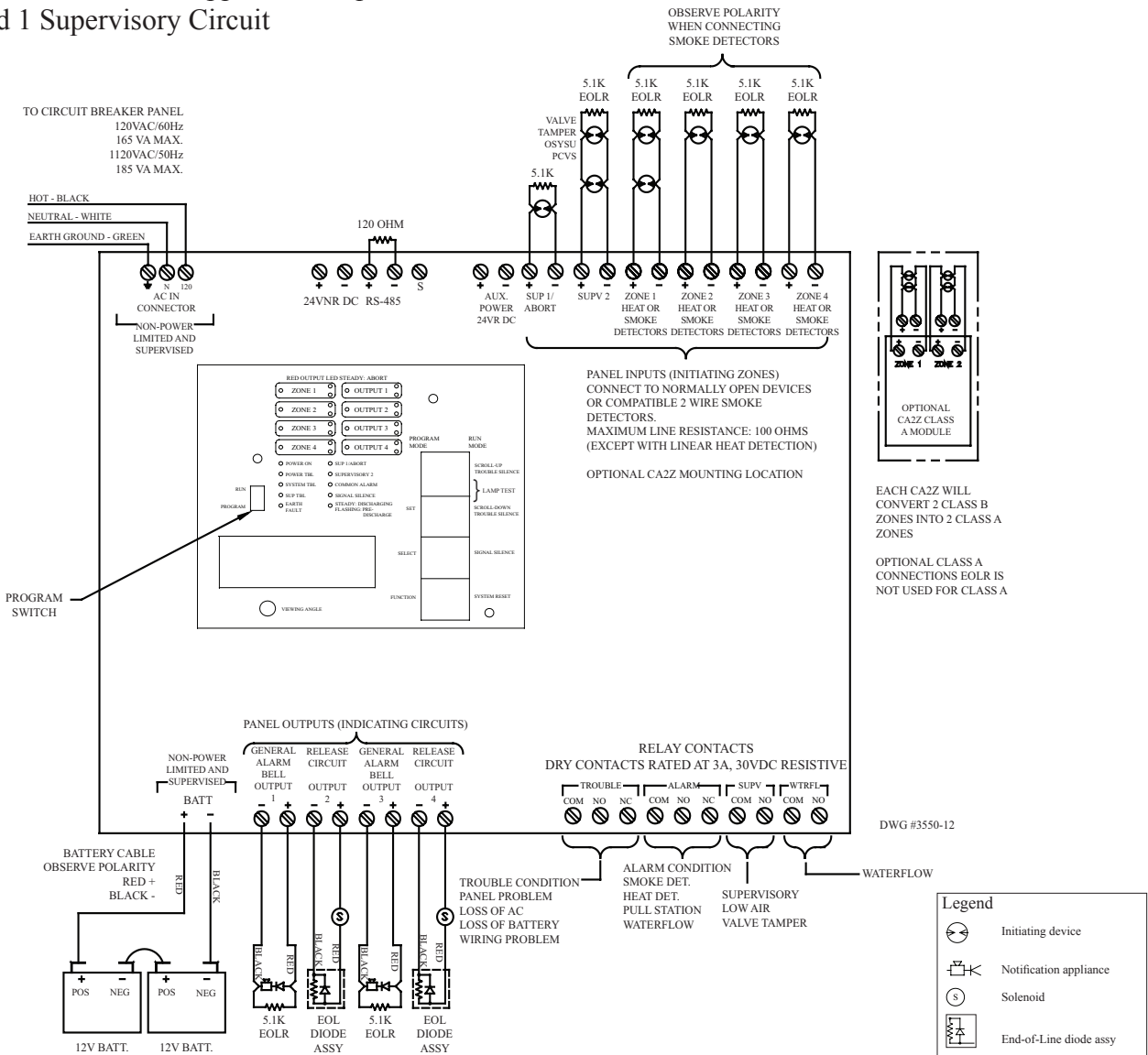

**NOTES:**

1. Connect only UL Listed 24VDC devices to indicating circuits.
2. Connect EOL Diode assembly IN SERIES with solenoid on release circuit
3. Leave EOLR (provided) on all unused circuits.
4. Polarity is shown on indicating circuits in an activated (off-normal) condition.
5. Polarity reverses when output is activated.
6. Maximum current per output is 1 Amp. Maximum voltage is 33VDC.
7. Outputs identified as Release are Special Application. All other outputs are Regulated 24 VDC, Rated 1 Amp each, 2.5 Amp total for all 4 circuits.
8. All initiating and NAC/Release circuits are supervised and power limited. See note 3 on page 90 for power limited wire routing instructions. All frequencies are continuous.
9. Refer to pgs. 16, 83-85 for installation, test and maintenance information.
10. Maximum resistance on outputs is 10 ohms. Maximum resistance on outputs programmed as releasing, is 1 divided by current requirements of solenoid.
11. Notification outputs do not provide synchronization. If synchronization is needed, refer to the NAC Compatibility Document, 5403592. Synchronization is only on one circuit and not between circuits. The maximum cannot exceed 1 amp or whatever the maximum that the sync' module can support, whichever is lower.

See page 89 for smoke detector compatibility data.

See page 85 for battery information.

**Program #21 Mode**

1. Apply power to panel.
2. Move the program switch down.
3. Press the FUNCTION button until the display reads “PASSWORD = 000”.
4. To enter a password, press the SELECT button until the proper number is displayed above the ^ symbol, then press the SET button to move to the next digit. After entering the third number the display will change.  
(All panels are shipped with a 000 password.)
5. Press the FUNCTION button until the display reads “PROGRAM #0”.
6. Press the SELECT button until the display reads “PROGRAM #21”.
7. Press the SET button.
8. Press the SELECT button to change the pre-discharge time.
9. Press the SET button to enter the pre-discharge time displayed.
10. Press the SELECT button to change the abort mode. See page 11 for abort mode selections.
11. Press the SET button to enter the abort mode displayed.
12. The panel is completely programmed except for the custom banner and zone messages. Move the program switch back up.

PROGRAM #21					
	ZONES				
	SUPERVISORY 2	#1	#2	#3	#4
OUTPUTS	Supervisory	Detection	Detection	Detection	Detection
#1 ALARM INDICATING		X	X		
#2 RELEASE		X	X		
#3 ALARM INDICATING				X	X
#4 RELEASE				X	X

SUP 1 defaults to abort

Description: Dual Hazard, 2 detection zones mapped to 1 release circuit and 2 other detection zones mapped to another release circuit

Inputs: 1 supervisory zone, 4 detection zones, 1 abort circuit

Outputs: 2 general alarm, 2 release circuit

Operation: Activation of either detection zone 1 or 2 will activate the alarm output #1 and start the pre-discharge timer for the release circuit output #2

Activation of either detection zone 3 or 4 will activate the alarm output #3 and start the pre-discharge timer for the release circuit output #2

When either zone 1 or 2 is in alarm, outputs 1 & 2 will operate

When either zone 3 or 4 is in alarm, outputs 3 & 4 will operate



Wiring Diagram Program #22  
 Single Hazard, 2 Detection Zones Cross-zoned to  
 1 Release Circuit, 1 Manual Station and A Discharge  
 Confirmation Zone

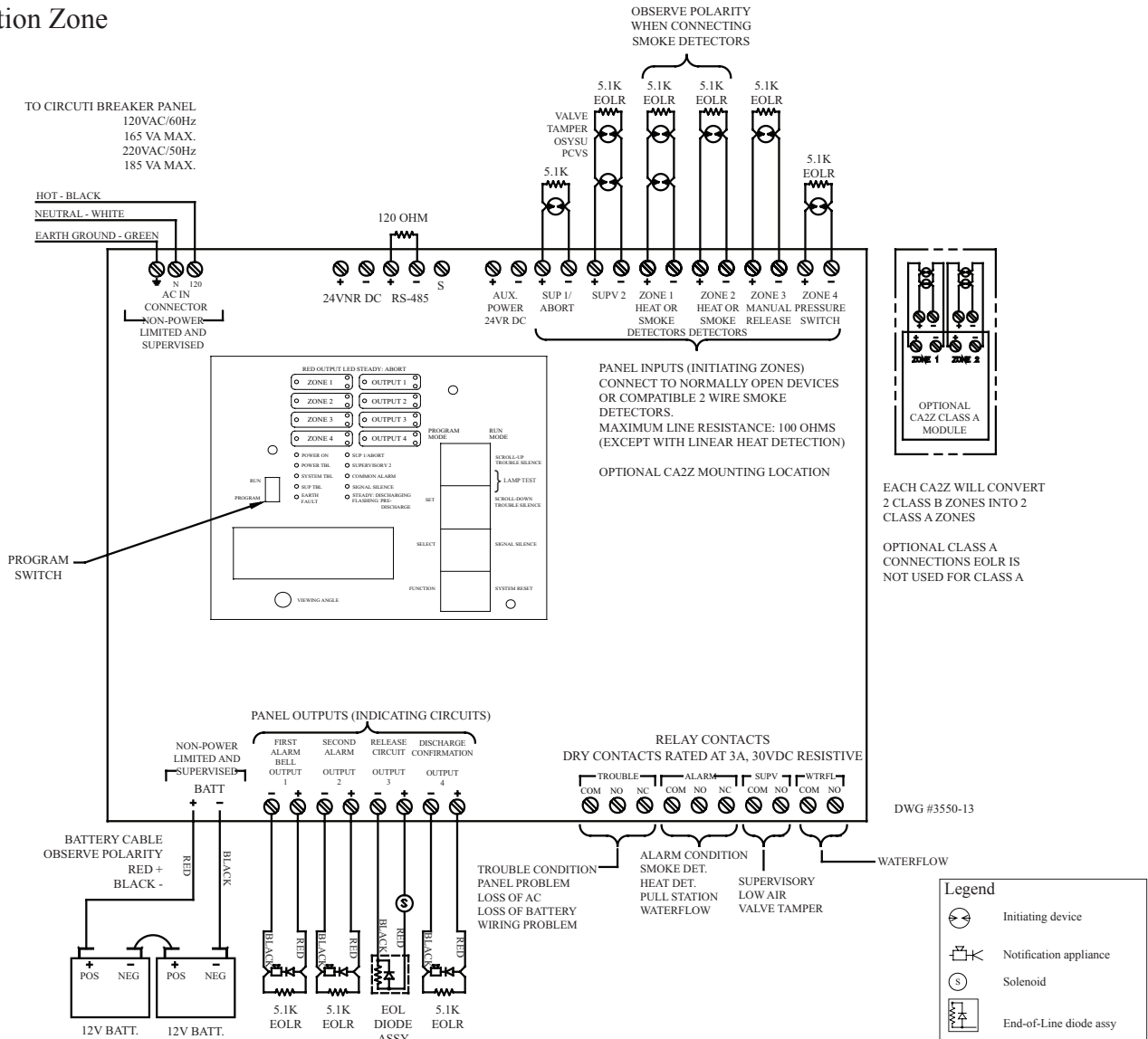

NOTES:

1. Connect only UL Listed 24VDC devices to indicating circuits.
2. Connect EOL Diode assembly IN SERIES with solenoid on release circuit
3. Leave EOLR (provided) on all unused circuits.
4. Polarity is shown on indicating circuits in an activated (off-normal) condition.
5. Polarity reverses when output is activated.
6. Maximum current per output is 1 Amp. Maximum voltage is 33VDC.
7. Outputs identified as Release are Special Application. All other outputs are Regulated 24 VDC, Rated 1 Amp each, 2.5 Amp total for all 4 circuits.
8. All initiating and NAC/Release circuits are supervised and power limited. See note 3 on page 90 for power limited wire routing instructions. All frequencies are continuous.
9. Refer to pgs. 16, 83-85 for installation, test and maintenance information.
10. Maximum resistance on outputs is 10 ohms. Maximum resistance on outputs programmed as releasing, is 1 divided by current requirements of solenoid.
11. Notification outputs do not provide synchronization. If synchronization is needed, refer to the NAC Compatibility Document, 5403592. Synchronization is only on one circuit and not between circuits. The maximum cannot exceed 1 amp or whatever the maximum that the sync' module can support, whichever is lower.

See page 89 for smoke detector compatibility data.

See page 85 for battery information.

**Program #22 Mode**

1. Apply power to panel.
2. Move the program switch down.
3. Press the FUNCTION button until the display reads “PASSWORD = 000”.
4. To enter a password, press the SELECT button until the proper number is displayed above the ^ symbol, then press the SET button to move to the next digit. After entering the third number the display will change.  
(All panels are shipped with a 000 password.)
5. Press the FUNCTION button until the display reads “PROGRAM #0”.
6. Press the SELECT button until the display reads “PROGRAM #22”.
7. Press the SET button.
8. Press the SELECT button to change the pre-discharge time.
9. Press the SET button to enter the pre-discharge time displayed.
10. Preset the SELECT button to change the manual release pre-discharge time. See page 11 for abort mode selections.
11. Press the SET button to enter the manual release pre-discharge time displayed.
12. Press the SELECT button to change the abort mode.
13. Press the SET button to enter the abort mode displayed.
14. The panel is completely programmed except for the custom banner and zone messages. Move the program switch back up.

PROGRAM #22					
	ZONES				
	SUPERVISORY 2	#1	#2	#3	#4
OUTPUTS	Supervisory	Detection	Detection	Manual Release	Detection
#1 FIRST ALARM		X	X		
#2 SECOND ALARM		X	X	X	
#3 RELEASE		XX	XX	X	
#4 ALARM INDICATING					X

SUP 1 defaults to abort  
XX = Cross-Zoned

**Description:** Single Hazard, 2 detection zones cross-zoned to 1 release circuit. A manual station zone and a discharge confirmation zone. Also first and second alarm notification circuits.

**Inputs:** 1 supervisory zone, 3 detection zones, 1 manual station zone, 1 abort circuit

**Outputs:** 3 general alarm, 1 release circuit

**Operation:** Activation of either detection zones 1 or 2 will activate the alarm output #1  
 Activation of both detection circuits at the same time will activate the alarm outputs #1, #2 and start the pre-discharge timer for the release circuit output #3  
 Activation of the manual release zone #3 will activate the alarm output #2 and start the manual release pre-discharge timer for release circuit output #3  
 Activation of zone 4 will operate output #4

When either zone 1 or 2 is in alarm, output 1 will operate  
 When both zones 1 and 2 are in alarm at the same time, outputs #1,2 will operate and the pre-discharge timer for output #3 will start  
 When zone 3 is in alarm, output 2 will operate and the manual release pre-discharge timer for output #3 will start  
 When zone 4 is in alarm, output #4 will operate



**Program #23 Mode**

1. Apply power to panel.
2. Move the program switch down.
3. Press the FUNCTION button until the display reads “PASSWORD = 000”
4. To enter a password, press the SELECT button until the proper number is displayed above the ^ symbol, then press the SET button to move to the next digit. After entering the third number the display will change.  
(All panels are shipped with a 000 password.)
5. Press the FUNCTION button until the display reads “PROGRAM #0”.
6. Press the SELECT button until the display reads “PROGRAM #23”.
7. Press the SET button.
8. Press the SELECT button to change the pre-discharge time.
9. Press the SET button to enter the pre-discharge time displayed.
10. Press the SELECT button to change the abort mode. See page 11 for abort selections.
11. Press the SET button to enter the abort mode displayed.
12. The panel is completely programmed except for the custom banner and zone messages. Move the program switch back up.

PROGRAM #23					
	ZONES				
	SUPERVISORY 2	#1	#2	#3	#4
OUTPUTS	Supervisory	Detection	Detection	Detection	Detection
#1 ALARM INDICATING		X	X	X	X
#2 TROUBLE					
#3 SUPERVISORY	X				
#4 RELEASE		X	X	X	X

SUP 1 defaults to abort

Description: Single Hazard, 4 detection zones mapped to 1 release  
 Inputs: 1 supervisory zone, 4 detection zones, 1 abort circuit  
 Outputs: 1 general alarm, 1 trouble, 1 supervisory, 1 release circuit  
 Operation: Activation of any detection zone will activate the alarm output #1 and start the pre-discharge timer for the release circuit output #4.  
 Activation of the supervisory zone will operate the supervisory bell.  
 A trouble condition (low battery, wire problem, etc.) will operate the trouble bell.

When either zone 1, 2, 3, or 4 is in alarm, outputs 1 & 4 will operate  
 When the supervisory zone is activated - output #3 (supervisory bell) will operate.  
 When the panel is in a trouble condition - output #2 (trouble bell) will operate.

# Wiring Diagram Program #24

## Single Hazard, 2 Detection Zones 1 Manual Station Zone and A Discharge Confirmation Zone

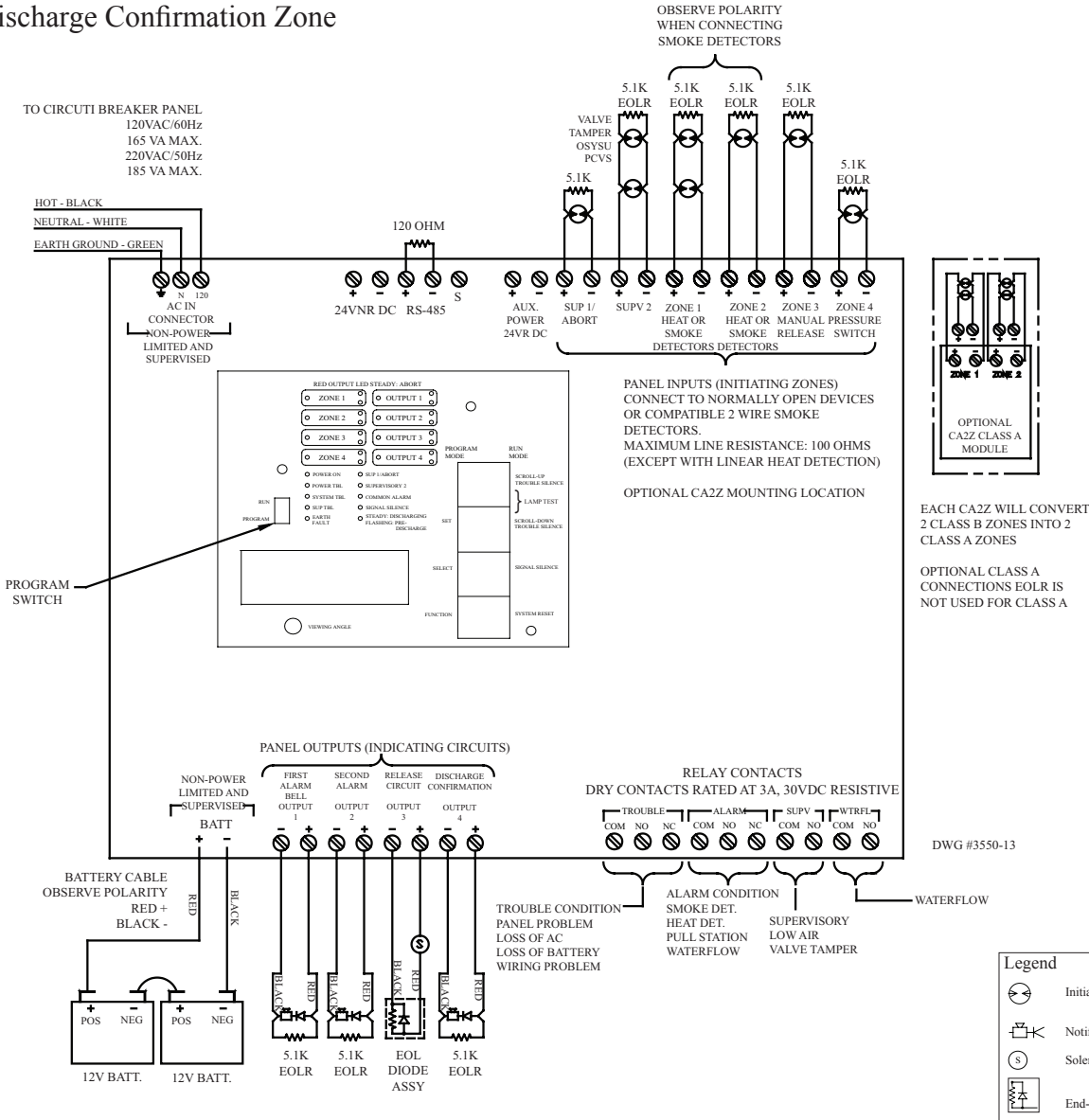

**NOTES:**

1. Connect only UL Listed 24VDC devices to indicating circuits.
2. Connect EOL Diode assembly IN SERIES with solenoid on release circuit
3. Leave EOLR (provided) on all unused circuits.
4. Polarity is shown on indicating circuits in an activated (off-normal) condition.
5. Polarity reverses when output is activated.
6. Maximum current per output is 1 Amp. Maximum voltage is 33VDC.
7. Outputs identified as Release are Special Application. All other outputs are Regulated 24 VDC, Rated 1 Amp each, 2.5 Amp total for all 4 circuits.
8. All initiating and NAC/Release circuits are supervised and power limited. See note 3 on page 90 for power limited wire routing instructions. All frequencies are continuous.
9. Refer to pgs. 16, 83-85 for installation, test and maintenance information.
10. Maximum resistance on outputs is 10 ohms. Maximum resistance on outputs programmed as releasing, is 1 divided by current requirements of solenoid.
11. Notification outputs do not provide synchronization. If synchronization is needed, refer to the NAC Compatibility Document, 5403592. Synchronization is only on one circuit and not between circuits. The maximum cannot exceed 1 amp or whatever the maximum that the sync' module can support, whichever is lower.

See page 89 for smoke detector compatibility data.  
See page 85 for battery information.

**Program #24 Mode**

1. Apply power to panel.
2. Move the program switch down.
3. Press the FUNCTION button until the display reads “PASSWORD = 000”.
4. To enter a password, press the SELECT button until the proper number is displayed above the ^ symbol, then press the SET button to move to the next digit. After entering the third number the display will change.  
(All panels are shipped with a 000 password.)
5. Press the FUNCTION button until the display reads “PROGRAM #0”.
6. Press the SELECT button until the display reads “PROGRAM #24”.
7. Press the SET button.
8. Press the SELECT button to change the pre-discharge time.
9. Press the SET button to enter the pre-discharge time displayed.
10. Press the SELECT button to change the manual release pre-discharge time. See page 11 for abort selections.
11. Press the SET button to enter the manual release pre-discharge time selected.
12. Press the SELECT button to change the abort mode.
13. Press the SET button to enter the abort mode displayed.
14. The panel is completely programmed except for the custom banner and zone messages. Move the program switch back up.

PROGRAM #24					
	ZONES				
	SUPERVISORY 2	#1	#2	#3	#4
OUTPUTS	Supervisory	Detection	Detection	Manual Release	Low Air
#1 ALARM INDICATING		X	X		
#2 ALARM INDICATING				X	
#3 RELEASE		X	X	X	
#4 SUPERVISORY	X				X

SUP 1 defaults to abort

- Description: Single Hazard, 2 detection zones, a manual station zone and a discharge confirmation zone.  
 Inputs: 1 supervisory zone, 1 low air zone, 2 detection zones, 1 manual station zone, 1 abort circuit  
 Outputs: 2 general alarm, 1 release circuit, 1 supervisory  
 Operation: Activation of either detection zones 1 or 2 will activate the alarm output #1 and start the pre-discharge timer for the release circuit output #3  
 Activation of the manual release zone #3 will activate the alarm output #2 and start the manual release pre-discharge timer for release circuit output #3  
 Activation of zone 4 will operate output #4

When either zone 1 or 2 is in alarm, output 1 will operate and the pre-discharge timer for output #3 will start  
 When zone 3 is in alarm, output 2 will operate and the manual release pre-discharge timer for output #3 will start.  
 When zone 4 is activated, output #4 will operate

Wiring Diagram Program #25

Dual Hazard, 2 Detection Zones Cross-Zoned to 1 eAEROSOL Circuit and 2 Other Detection Zones Cross-Zoned to a Separate eAEROSOL Circuit, 1 Abort Circuit, and 1 Supervisory Circuit

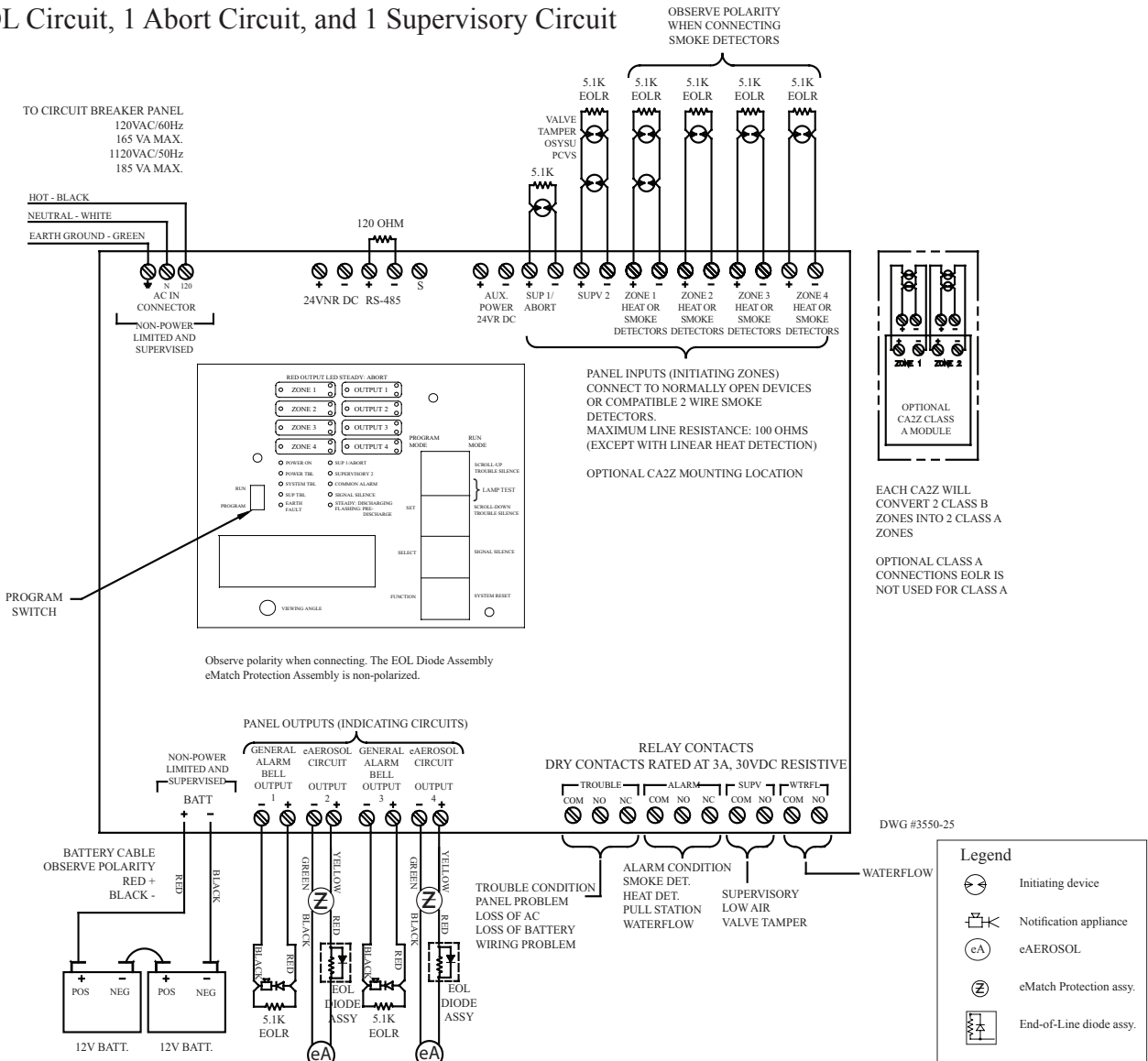

NOTES:

1. Connect only UL Listed 24VDC devices to indicating circuits.
  2. Connect EOL Diode assembly IN SERIES with aerosol on eAEROSOL circuit.
  3. Connect eMatch Protection IN PARALLEL with aerosol on eAEROSOL circuit.
  4. Leave EOLR (provided) on all unused circuits.
  5. Polarity is shown on indicating circuits in an activated (off-normal) condition.
  6. Polarity reverses when output is activated.
  7. Maximum current per output is 1 Amp. Maximum voltage is 33VDC.
  8. Outputs identified as Release are Special Application. All other outputs are Regulated 24 VDC, Rated 1 Amp each, 2.5 Amp total for all 4 circuits.
  9. All initiating and NAC/eAEROSOL circuits are supervised and power limited. See note 3 on page 90 for power limited wire routing instructions. All frequencies are continuous.
  10. Refer to pgs. 16, 83-85 for installation, test and maintenance information.
  11. Maximum resistance on outputs is 10 ohms. Maximum resistance on outputs programmed as releasing, is 1 divided by current requirements of solenoid.
  12. Notification outputs do not provide synchronization. If synchronization is needed, refer to the NAC Compatibility Document, 5403592. Synchronization is only on one circuit and not between circuits. The maximum cannot exceed 1 amp or whatever the maximum that the sync' module can support, whichever is lower.
- See page 89 for smoke detector compatibility data.
- See page 85 for battery information.



**Program #25 Mode**

1. Apply power to panel.
2. Move the program switch down.
3. Press the FUNCTION button until the display reads “PASSWORD = 000”.
4. To enter a password, press the SELECT button until the proper number is displayed above the ^ symbol, then press the SET button to move to the next digit. After entering the third number the display will change.  
(All panels are shipped with a 000 password.)
5. Press the FUNCTION button until the display reads “PROGRAM #0”.
6. Press the SELECT button until the display reads “PROGRAM #25”.
7. Press the SET button.
8. Press the SELECT button to change the pre-discharge time.
9. Press the SET button to enter the pre-discharge time displayed.
10. Press the SELECT button to change the abort mode. See page 11 for abort mode selections.
11. Press the SET button to enter the abort mode displayed.
12. The panel is completely programmed except for the custom banner and zone messages. Move the program switch back up.

PROGRAM #25					
	ZONES				
	SUPERVISORY 2	#1	#2	#3	#4
OUTPUTS	Supervisory	Detection	Detection	Detection	Detection
#1 ALARM INDICATING		X	X		
#2 eAEROSOL		XX	XX		
#3 ALARM INDICATING				X	X
#4 eAEROSOL				XX	XX

SUP 1 defaults to abort  
XX = Cross-Zoned

- Description: Dual Hazard, 2 detection zones cross-zoned to 1 eAEROSOL circuit and 2 other detection zones cross-zoned to another eAEROSOL circuit
- Inputs: 1 supervisory zone, 4 detection zones, 1 abort circuit
- Outputs: 2 general alarms, 2 eAEROSOL circuits
- Operation: Activation of either detection zone 1 or 2 will activate the alarm output #1.  
Activation of both Zones 1 and 2 simultaneously will activate the alarm output #1 and start the pre-discharge timer for the eAEROSOL circuit output #2.  
Activation of either detection zone 3 or 4 will activate the alarm output #3.  
Activation of both Zones 3 and 4 simultaneously will activate the alarm output #3 and start the pre-discharge timer for the eAEROSOL circuit output #4.
- When either zone 1 or 2 is in alarm, output 1 will operate.  
When both zones 1 or 2 are in alarm simultaneously, the pre-discharge timer to output 2 will operate.  
When either zone 3 or 4 is in alarm, output 3 will operate.  
When both zones 3 or 4 are in alarm simultaneously, the pre-discharge timer to output 4 will operate.



**Program #26 Mode**

1. Apply power to panel.
2. Move the program switch down.
3. Press the FUNCTION button until the display reads “PASSWORD = 000”.
4. To enter a password, press the SELECT button until the proper number is displayed above the ^ symbol, then press the SET button to move to the next digit. After entering the third number the display will change.  
(All panels are shipped with a 000 password.)
5. Press the FUNCTION button until the display reads “PROGRAM #0”.
6. Press the SELECT button until the display reads “PROGRAM #26”.
7. Press the SET button.
8. Press the SELECT button to change the pre-discharge time.
9. Press the SET button to enter the pre-discharge time displayed.
10. Preset the SELECT button to change the manual release pre-discharge time. See page 11 for abort mode selections.
11. Press the SET button to enter the manual release pre-discharge time displayed.
12. Press the SELECT button to change the abort mode.
13. Press the SET button to enter the abort mode displayed.
14. The panel is completely programmed except for the custom banner and zone messages. Move the program switch back up.

PROGRAM #26					
	ZONES				
	SUPERVISORY 2	#1	#2	#3	#4
OUTPUTS	Supervisory	Detection	Detection	Detection	Manual Release
#1 FIRST ALARM		X	X	X	
#2 SECOND ALARM		X	X		X
#3 eAEROSOL		XX	XX		X
#4 eAEROSOL		XX	XX		X

SUP 1 defaults to abort  
XX = Cross-Zoned

**Description:** Single Hazard, 2 detection zones cross-zoned to 2 release circuits. A manual station zone. Also first and second alarm notification circuits.

**Inputs:** 1 supervisory zone, 3 detection zones, 1 manual station zone, 1 abort circuit

**Outputs:** 2 general alarm, 2 eAEROSOL circuits

**Operation:** Activation of either detection zones 1 or 2 will activate the alarm output #1  
Activation of both detection circuits at the same time will activate the alarm outputs #1, #2 and start the pre-discharge timer for the eAEROSOL circuits output #3 and #4  
Activation of zone 3 will operate output #1  
Activation of the manual release Zones 4 will operate output #2 and start the pre-discharge timer for the eAEROSOL circuits output #3 and #4.

When either zone 1 or 2 is in alarm, output 1 will operate  
When both zones 1 and 2 are in alarm at the same time, outputs #1,2 will operate and the pre-discharge timer for outputs #3 and #4 will start  
When zone 3 is in alarm, output #1 will operate  
When zone 4 is in alarm, output 2 will operate and the manual release pre-discharge timer for outputs #3 and #4 will start



**Program #27 Mode**

1. Apply power to panel.
2. Move the program switch down.
3. Press the FUNCTION button until the display reads “PASSWORD = 000”
4. To enter a password, press the SELECT button until the proper number is displayed above the ^ symbol, then press the SET button to move to the next digit. After entering the third number the display will change.  
(All panels are shipped with a 000 password.)
5. Press the FUNCTION button until the display reads “PROGRAM #0”.
6. Press the SELECT button until the display reads “PROGRAM #27”.
7. Press the SET button.
8. Press the SELECT button to change the pre-discharge time.
9. Press the SET button to enter the pre-discharge time displayed.
10. Press the SELECT button to change the abort mode. See page 11 for abort selections.
11. Press the SET button to enter the abort mode displayed.
12. The panel is completely programmed except for the custom banner and zone messages. Move the program switch back up.

PROGRAM #27					
	ZONES				
	SUPERVISORY 2	#1	#2	#3	#4
OUTPUTS	Supervisory	Detection	Detection	Manual Release	Detection
#1 FIRST ALARM		X	X		
#2 SECOND ALARM		X	X	X	
#3 eAEROSOL		XX	XX	X	
#4 ALARM INDICATING					X

SUP 1 defaults to abort  
XX = Cross-Zoned

Description: Single Hazard, 2 detection zones cross-zoned to 1 eAEROSOL  
 Inputs: 1 supervisory zone, 3 detection zones, 1 abort circuit, a manual station zone  
 Outputs: 3 general alarm, 1 eAEROSOL circuit  
 Operation: Activation of either detection zones 1 or 2 will activate the alarm output #1  
 Activation of both detection circuits at the same time will activate the alarm outputs #1, #2 and start the pre-discharge timer for the eAEROSOL circuit output #3  
 Activation of the manual release zone 3 will activate the alarm output #2 and start the manual release pre-discharge timer for the eAEROSOL circuit output #3  
 Activation of zone 4 will operate output #4

When either zone 1 or 2 is in alarm, output 1 will operate  
 When both zones 1 and 2 are in alarm at the same time, outputs #1,2 will operate and the pre-discharge timer for output #3 will start  
 When zone 3 is in alarm, output #2 will operate and the manual release pre-discharge timer for output #3 will start.  
 When zone 4 is in activated, output #4 will operate.



**Program #28 Mode**

1. Apply power to panel.
2. Move the program switch down.
3. Press the FUNCTION button until the display reads “PASSWORD = 000”.
4. To enter a password, press the SELECT button until the proper number is displayed above the ^ symbol, then press the SET button to move to the next digit. After entering the third number the display will change.  
(All panels are shipped with a 000 password.)
5. Press the FUNCTION button until the display reads “PROGRAM #0”.
6. Press the SELECT button until the display reads “PROGRAM #28”.
7. Press the SET button.
8. Press the SELECT button to change the pre-discharge time.
9. Press the SET button to enter the pre-discharge time displayed.
10. Press the SELECT button to change the manual release pre-discharge time. See page 11 for abort selections.
11. Press the SET button to enter the manual release pre-discharge time selected.
12. Press the SELECT button to change the abort mode.
13. Press the SET button to enter the abort mode displayed.
14. The panel is completely programmed except for the custom banner and zone messages. Move the program switch back up.

PROGRAM #28					
	ZONES				
	SUPERVISORY 2	#1	#2	#3	#4
OUTPUTS	Supervisory	Detection	Detection	Detection	Manual Release
#1 ALARM INDICATING		X	X	X	X
#2 ALARM INDICATING		X	X	X	X
#3 eAEROSOL		X	X	X	X
#4 SUPERVISORY	X				

SUP 1 defaults to abort

Description: Single Hazard, 3 detection zones, and a manual station zone  
 Inputs: 1 supervisory zone, 3 detection zones, 1 manual station zone, 1 abort circuit  
 Outputs: 2 general alarm, 1 eAEROSOL circuit, 1 supervisory  
 Operation: Activation of either detection zones 1, 2, or 3 will activate the alarm output #1 and #2 and start the pre-discharge timer for the eAEROSOL circuit output #3  
 Activation of the manual release zone #4 will activate the alarm outputs #1 and #2 and start the manual release pre-discharge timer for eAEROSOL circuit output #3.  
 Activation of Supervisory 2 will activate output #4.

When either zone 1, 2, or 3 is in alarm, outputs #1 and #2 will operate and the pre-discharge timer for output #3 will start  
 When zone 4 is in alarm, outputs #1 and #2 will operate and the manual release pre-discharge timer for output #3 will start.



CUSTOM PROGRAM						
	ZONES					
	SUP 1/ABORT	SUP 2	#1	#2	#3	#4
OUTPUTS	*Supervisory or Abort	Supervisory				
#1						
#2						
#3						
#4						

\* If SUP 1/Abort zone is programmed as abort, activation of that zone will not operate any output circuits.

### Wiring Diagram Custom Program

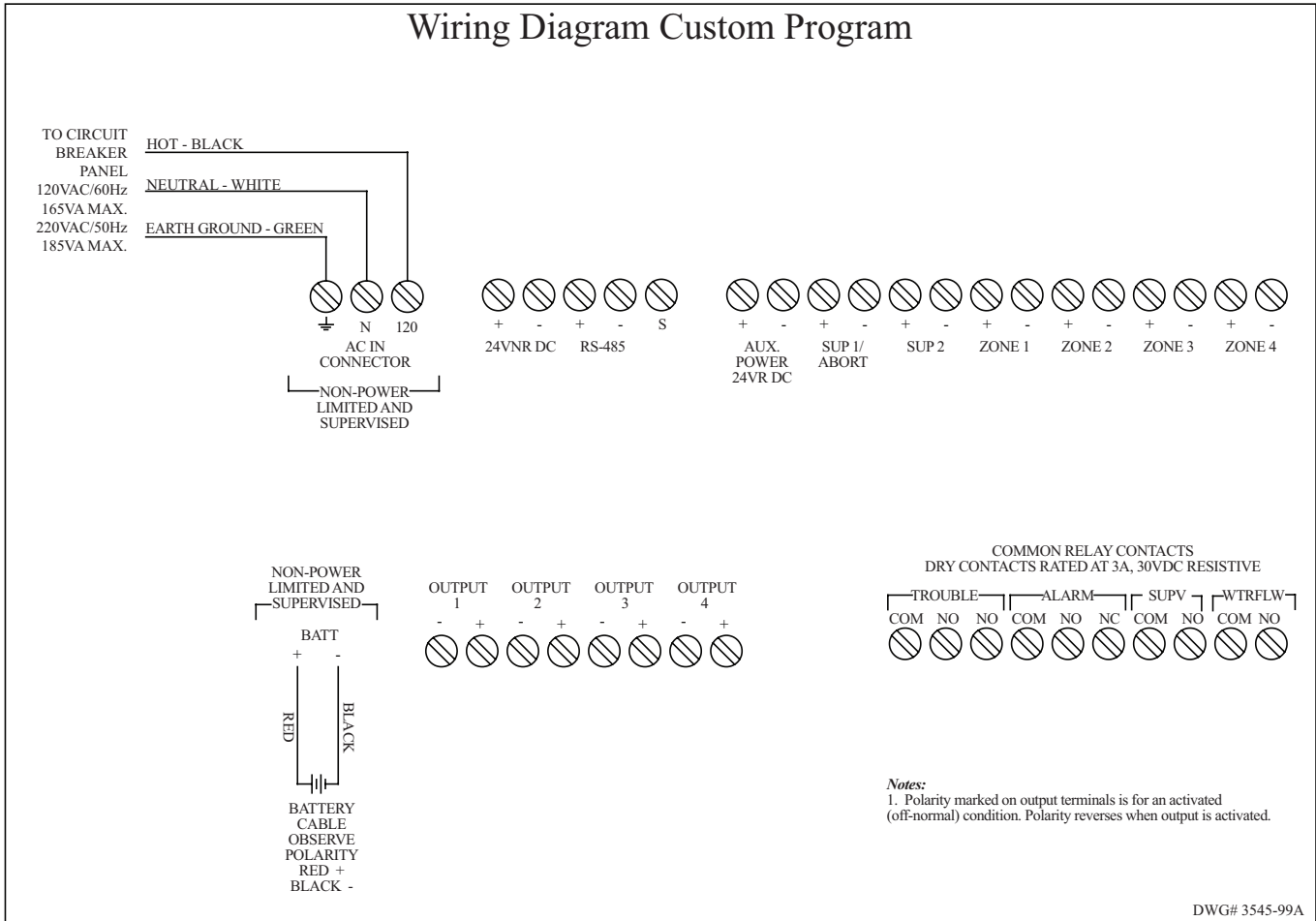

### PFC-4410RC Custom Program Information for Water Based Extinguishing Systems

If the user has selected program # 0 for a custom configuration of the panel the following will appear in the display window.

P	R	O	G	R	A	M	T	Y	P	E	:			
W	A	T	E	R		B	A	S	E	D				

This display allows the user to select functions for either water or chemical based extinguishing systems. This window is for water based, to toggle from water based to chemical based or visa versa, press the SELECT button

**SET**  Press the SET button to set the description displayed into the panels program

**SELECT**  Press the SELECT button to scroll between water or chemical based modes

**FUNCTION**  Press the FUNCTION button to skip to the next function

After setting the WATER BASED mode or pressing FUNCTION, the following will appear in the display:

I	N	I	T		Z	O	N	E	#	1				
D	E	T	E	C	T	I	O	N						

#### Initiating Zone Description

This allows the user to describe the initiating zones. Nine different descriptions are available. They are:

- 1) DETECTION - These include smoke detectors, pull stations, heat detectors and other devices put on a conventional zone.
- 2) WATERFLOW - Alarms from waterflow zones are non-silenceable
- 3) LINEAR HEAT DETECTION - These use a special wire with a fuseable insulation
- 4) MANUAL RELEASE - Used to override cross zoning and cause instant release
- 5) LOW AIR ALARM – This is for a low air switch used in a double interlock system. Usually cross zoned with a smoke or heat detector. Activation of this zone creates a supervisory condition on the panel but can still operate the release circuit.
- 6) SUPERVISORY - For monitoring any supervisory function as assigned
- 7) TAMPER - For control valve monitoring
- 8) LOW AIR - Used to detect low air pressure
- 9) HIGH AIR - Used to detect high air pressure

The first four descriptions (DETECTION, WATERFLOW, LINEAR HEAT DETECTION and MANUAL RELEASE) are Alarm Zones. When activated, they will put the panel into alarm and operate the appropriate output as well as operating the alarm relay.

The 5<sup>th</sup> description (LOW AIR ALARM) creates a supervisory condition on the panel but can be used to activate the release circuit. This activates the Supervisory relay not the Alarm relay.

The last four descriptions (SUPERVISORY, TAMPER, LOW AIR and HIGH AIR) are Supervisory Zones. When activated, they will put the panel in a supervisory condition and activate any output described as “SUPERVISORY BELL”. They cannot activate the release circuit

**SET**  Press the SET button to set the description displayed.

**SELECT**  Press the SELECT button to scroll through the nine descriptions.

**FUNCTION**  Press the FUNCTION button to skip to the next function.

After describing all initiating zones or skipping to the next function, the following will appear in the display window:

S	U	P	E	R	V	S	R	Y		1		Z	O	N	E
S	U	P	E	R	V	I	S	R	Y						

Supervisory 1 is a supervisory or abort zone and can only be described as SUPERVISORY, TAMPER, LOW AIR or HIGH AIR, or ABORT.

**SET**  Press the SET button to set the description displayed.

**SELECT**  Press the SELECT button to scroll through the four supervisory and abort descriptions.

**FUNCTION**  Press the FUNCTION button to skip to the next function.

After describing what the supervisory zone is to be or skipping to the next function, the following will appear in the display window:

S	U	P	E	R	V	S	R	Y		2		Z	O	N	E
S	U	P	E	R	V	I	S	R	Y						

**SET**  Press the SET button to set the description displayed.

**SELECT**  Press the SELECT button to scroll through the four supervisory and abort descriptions.

**FUNCTION**  Press the FUNCTION button to skip to the next function.

After describing what the supervisory zone is to be or skipping to the next function, the following will appear in the display window:

O	U	T	P	U	T		#	1							
I	N	D	I	C	A	T	I	N	G						

**Output Description**

This allows the user to describe the functions of the output circuits. Four descriptions are available:

- 1) ALARM INDICATING - Indicating appliances include bells, horns, strobes and other appliances used to indicate an alarm.
- 2) RELEASING - Releasing appliances include solenoids and other electrically compatible devices.
- 3) eAEROSOL – To be used with Aerosol Generators only. Pulse Releasing Output, 1/16th sec on, 15/16th sec off. Available only with chemical programs. Will turn off after 200 pulses (200 seconds).
- 4) SUPERVISORY BELL - Appliances on this circuit are used to indicate the presence of a supervisory condition. Any zone programmed as LOW AIR ALARM, SUPERVISORY, TAMPER, HI AIR or LOW AIR is automatically mapped to this output.
- 5) TROUBLE BELL - Appliances on this circuit are used to indicate the presence of a trouble condition. The user should describe each output circuit in the same manner as the initiating circuit was described by pressing the SELECT button to select and the SET button to set the desired function.

**SET**  Press the SET button to set the description displayed.

**SELECT**  Press the SELECT button to scroll through the descriptions.

**FUNCTION**  Press the FUNCTION button to skip to the next function.

After selecting all four outputs or pressing FUNCTION, the following will be displayed if any outputs have been described as RELEASING:

O	U	T	P	U	T		#	<	a	>					
N	O	R	M	A	L										

Where “<a>” is the number of the releasing circuit output.

**Normal/Cross-Zoning**

Each releasing circuit can be set up for the normal or cross zoned operation. In NORMAL operation, any alarm initiating zone including LOW AIR ALARM mapped to a releasing output must be in alarm before the output is activated. In cross zoned operation ALL initiating zones mapped to the releasing circuit must be in alarm before the output is activated. An initiating zone previously described as “MANUAL RELEASE” will override the cross zoning feature.

**SET**  Press the SET button to set the operation displayed.

**SELECT**  Press the SELECT button to toggle between NORMAL and CROSS ZONED.

**FUNCTION**  Press the FUNCTION button to skip to the next function.

After selecting normal or cross zone operation the next function will be displayed as follows:

D	I	S	C	H	A	R	G	E		T	I	M	E		
C	O	N	T	I	N	U	O	U	S						

**Releasing Output Time**

This allows the user to determine how long the releasing circuit is energized upon alarm. The available times are 7, 8, 9, 10 and 20 minutes and continuous (Potter recommends Continuous). Use the SELECT button to scroll through the possible options and the SET button to set that option. Press the FUNCTION button to skip to the next function.

**SET**  Press the SET button to set the time displayed.

**SELECT**  Press the SELECT button to scroll through the available time.

**FUNCTION**  Press the FUNCTION button to skip to the next function.

After choosing the discharge time, a display similar to the following will appear:

Z	O	N	E		1			V							
O	U	T	P	U	T	S	:		1		2		3		4

This display is where the outputs are mapped to the initiating zones. Any output that was previously described as “RELEASING” or “ALARM INDICATING” can be mapped to any initiating zones that were described as alarm zones, including zones programmed as LOW AIR ALARM.

Any initiating zone that was described as supervisory will automatically be mapped to outputs described as “SUPERVISORY BELL”, including zones programmed as LOW AIR ALARM. The “v” is pointing to the first available output for the zone indicated on the display. If the output number is displayed, it is turned on for that zone. If the number is not displayed, it is turned off. If an output is not available for that zone, i.e. “SUPERVISORY BELL”, the “v” will skip to the next available output.

**SET**  Press the SET button to set the output to the zone displayed and move to the next available output.

**SELECT**  Press the SELECT button to turn the output either on or off (the output number will be displayed when turned on).

**FUNCTION**  Press the FUNCTION button to skip to the next function.

After all available outputs for the zone displayed are mapped, the display will automatically change to the next zone. After mapping the last zone or skipping to the next function, the following will appear in the display window:

B	A	N	N	E	R		M	E	S	S	A	G	E	?	

**Custom Message**

To change the banner message, press the SELECT button. If you don't want to change the banner message press the FUNCTION button.

**SET**

**SELECT**  Press the SELECT button to change banner message.

**FUNCTION**  Press the FUNCTION button to skip to the next function.

If the SELECT button was pressed, the following will appear in the display window:

^															

The “^” is pointing to the first character on the top line. Press the SET button to scroll one direction through the character set, or press the SELECT button to scroll the other direction. The entire alphabet, numbers and punctuation are included.

**SET**  Press the SET button to scroll through the character set in one direction.

**SELECT**  Press the SELECT button to scroll in the opposite direction.

**FUNCTION**  Press the FUNCTION button to enter the character displayed and to move to the next position.

After programming the top line (maximum 10 characters), continue this process for the bottom line and the initiating zones. To keep the initiating zones as “ZONE 1”, etc., press the FUNCTION button when they are displayed.

When finished with the last zone, the following will appear in the display window:

N	E	W		P	A	S	S	W	O	R	D	=	0	0	0
													^		

This allows the user to change the password. All panels are shipped from the factory with a password of 000.

**SET**  Press the SET button to set the displayed number and move to the next space.

**SELECT**  Press the SELECT button to scroll through the numbers.

**FUNCTION**  Press the FUNCTION button to skip this function.

When finished with this section, the following will appear in the display window:

P	U	S	H		P	R	O	G	R	A	M	M	I	N	G
S	W	I	T	C	H		B	A	C	K		U	P		

Quit by returning the programming switch to the left position. The system is now ready for operation.

**PFC-4410RC Custom Program Information For Chemical Based Extinguishing Systems**

If the user has selected program # 0 for a custom configuration of the panel the following will appear in the display window.

P	R	O	G	R	A	M		T	Y	P	E	:			
W	A	T	E	R		B	A	S	E	D					

This display allows the user to select functions for either water or chemical based extinguishing systems. This window is for water based, to toggle from water based to chemical based or visa versa, press the SELECT button

**SET**  Press the SET button to set the description displayed into the panels program

**SELECT**  Press the SELECT button to scroll between water or chemical based modes

**FUNCTION**  Press the FUNCTION button to skip to the next function

After setting the CHEMICAL BASED mode or pressing FUNCTION, the following will appear in the display:

I	N	I	T		Z	O	N	E		#	1				
D	E	T	E	C	T	I	O	N							

**Initiating Zone Description**

This allows the user to describe the initiating zones. Nine different descriptions are available. They are:

- 1) DETECTION - These include smoke detectors, pull stations, heat detectors and other devices put on a conventional zone.
- 2) WATERFLOW - Alarms from waterflow zones are non-silenceable
- 3) LINEAR HEAT DETECTION - These use a special wire with a fuseable insulation
- 4) MANUAL RELEASE - Used to override cross zoning and cause instant release
- 5) LOW AIR ALARM – This is for a low air switch used in a double interlock system. Usually cross zoned with a smoke or heat detector. Activation of this zone creates a supervisory condition on the panel but can still operate the release circuit.
- 6) SUPERVISORY - For monitoring any supervisory function as assigned
- 7) TAMPER - For control valve monitoring
- 8) LOW AIR - Used to detect low air pressure
- 9) HIGH AIR - Used to detect high air pressure

The first four descriptions (DETECTION, WATERFLOW, LINEAR HEAT DETECTION and MANUAL RELEASE) are Alarm Zones. When activated, they will put the panel into alarm and operate the appropriate output as well as operating the alarm relay.

The 5<sup>th</sup> description (LOW AIR ALARM) creates a supervisory condition on the panel but can be used to activate the release circuit, this activates the Supervisory relay not the Alarm relay.

The last four descriptions (SUPERVISORY, TAMPER, LOW AIR and HIGH AIR) are Supervisory Zones. When activated, they will put the panel in a supervisory condition and activate any output described as “SUPERVISORY BELL”. They cannot activate the release circuit

**SET**  Press the SET button to set the description displayed.

**SELECT**  Press the SELECT button to scroll through the nine descriptions.

**FUNCTION**  Press the FUNCTION button to skip to the next function.

After describing all initiating zones or skipping to the next function, the following will appear in the display window:

S	U	P	E	R	V	S	R	Y		1		Z	O	N	E
A	B	O	R	T											

Zone 5 is a supervisory or abort zone and can only be described as SUPERVISORY, TAMPER, LOW AIR or HIGH AIR, or ABORT.

**SET**  Press the SET button to set the description displayed.

**SELECT**  Press the SELECT button to scroll through the four supervisory and abort descriptions.

**FUNCTION**  Press the FUNCTION button to skip to the next function.

S	U	P	E	R	V	S	R	Y		2		Z	O	N	E
S	U	P	E	R	V	I	S	R	Y						

Zone 6 is a supervisory zone and can only be described as SUPERVISORY, TAMPER, LOW AIR or HIGH AIR.

**SET**  Press the SET button to set the description displayed.

**SELECT**  Press the SELECT button to scroll through the four supervisory and abort descriptions.

**FUNCTION**  Press the FUNCTION button to skip to the next function.

After describing what the supervisory zone is to be or skipping to the next function, the following will appear in the display window:

O	U	T	P	U	T		#	1							
I	N	D	I	C	A	T	I	N	G						

**Output Description**

This allows the user to describe the functions of the output circuits and whether they indicate first or second alarm, or release activated. Four descriptions are available:

- 1) ALARM INDICATING - Indicating appliances include bells, horns, strobes and other appliances used to indicate an alarm. These outputs are also programmable as first or second alarm when in chemical mode. The outputs programmed as first alarm will activate continuously upon activation of any alarm zone mapped to that output. Outputs programmed as second alarm will continue to operate in a continuous mode.
- 2) RELEASING - Releasing appliances include solenoids and other electrically compatible devices.
- 3) eAEROSOL – To be used with Aerosol Generators only. Pulse Releasing Output, 1/16th sec on, 15/16th sec off. Available only with chemical programs. Will turn off after 200 pulses (200 seconds).
- 4) SUPERVISORY BELL - Appliances on this circuit are used to indicate the presence of a supervisory condition. Any zone programmed as LOW AIR ALARM, SUPERVISORY, TAMPER, HIGH AIR or LOW AIR is automatically mapped to this output.
- 5) TROUBLE BELL - Appliances on this circuit are used to indicate the presence of a trouble condition. The user should describe each output circuit in the same manner as the initiating circuit was described by pressing the SELECT button to select and the SET button to set the desired function.

**SET**  Press the SET button to set the description displayed.

**SELECT**  Press the SELECT button to scroll through the descriptions.

**FUNCTION**  Press the FUNCTION button to skip to the next function.





**Pre-discharge Timer for Alarm Zones**

A time delay of 0-60 seconds can be entered to delay the activation of the release circuit. The pre-discharge timer starts when all of the zones necessary for the operation of the release circuit have been activated. Pressing the SELECT button increases the time delay by one second. Pressing the SELECT button after 60 seconds is displayed will start the timer over at 0.

- SET**  Press the SET button to set the time displayed.
- SELECT**  Press the SELECT button to increase the time by one second.
- FUNCTION**  Press the FUNCTION button to skip to the next function.

If a zone has not been programmed as MANUAL RELEASE, skip to the next programming step.

If a zone has been programmed as MANUAL RELEASE, the following will appear in the display window after choosing an alarm zone pre-discharge time:

M	R		P	R	E	-	D	I	S	C	H	A	R	G	E
	1		S	E	C	O	N	D	S						

**Pre-Discharge timer for MANUAL RELEASE zones**

A time delay of 0-30 seconds can be entered to delay the activation of the release circuit. The pre-discharge timer starts when the manual release zone has been activated. Pressing the SELECT button increases the time delay by one second. Pressing the SELECT button after 30 seconds is displayed will start the timer over at 0.

- SET**  Press the SET button to set the time displayed.
- SELECT**  Press the SELECT button to increase the time by one second.
- FUNCTION**  Press the FUNCTION button to skip to the next function.

After choosing an alarm zone pre-discharge time, the following will appear in the display window:

A	B	O	R	T		T	Y	P	E	:					
U	L	I													

**Abort Modes**

The abort function is used to stop the release circuit from activating. Activation of the abort circuit will create a trouble condition.

- URI** – Activation of the abort circuit stops the pre-discharge timer at 10 seconds. If there is less than 10 seconds remaining, the timer goes back to 10 seconds. Releasing the abort button restarts the timer at 10 seconds. Activate again to repeat.
- IRI** – This mode, only functions if the release circuit is cross zoned. The IRI mode has the same functions as the ULI mode except the abort button must be pressed and held before the second zone necessary for the activation of the release circuit goes into alarm. Activation of the abort after the second alarm is received will have no effect. If the release circuit is not cross zoned, operation of the abort circuit in the IRI mode will not stop the release circuit.
- NYC** – This mode is not UL listed. This is a one shot function. Activation of the abort circuit will add 90 seconds to the original pre-discharge time. The countdown with the additional 90 seconds will begin when the abort button is released. Pressing the abort button again will have no effect.
- 30-Second Abort** – Activation of the abort circuit will stop the pre-discharge timer at 30 seconds. If there is less than 30 seconds remaining, the timer goes back to 30 seconds. Releasing the abort button re-starts the timer. Activate again to repeat.

## ⚠ WARNING

- \*The abort zone is a non-latching zone. In order for the abort function to operate, the abort button must be pressed and held continuously. Releasing the abort button will continue the pre-discharge timer.
- \*The abort function will not prevent the activation of the release circuit if a zone programmed as MANUAL RELEASE has been activated. MANUAL RELEASE always overrides the abort function.
- \*The abort function will not prevent the activation of the release circuit if there is no pre-discharge time set or if the pre-discharge time is 1 second or less when the abort button is pressed.

The next function will be displayed as follows:

D	I	S	C	H	A	R	G	E		T	I	M	E		
C	O	N	T	I	N	U	O	U	S						

### Releasing Output Time

This allows the user to determine how long the releasing circuit is energized upon alarm. The available times are 7, 8, 9, 10, 20 minutes and continuous. Use the SELECT button to scroll through the possible options and the SET button to set that option. Press the FUNCTION button to skip to the next function.

**SET**  Press the SET button to set the time displayed.

**SELECT**  Press the SELECT button to scroll through the available time.

**FUNCTION**  Press the FUNCTION button to skip to the next function.

After a discharge time is entered, a display similar to the following will appear:

Z	O	N	E		1			V							
O	U	T	P	U	T	S	:		1		2		3		4

This display is where the outputs are mapped to the initiating zones. Any output that was previously described as “RELEASING” or “ALARM INDICATING” can be mapped to any initiating zones that were described as alarm zones, including zones programmed as LOW AIR ALARM. Any initiating zone that was described as supervisory will automatically be mapped to outputs described as “SUPERVISORY BELL”, including zones programmed as LOW AIR ALARM. The “v” is pointing to the first available output for the zone indicated on the display. If the output number is displayed, it is turned on for that zone. If the number is not displayed, it is turned off. If an output is not available for that zone, i.e. “SUPERVISORY BELL”, the “v” will skip to the next available output.

**SET**  Press the SET button to set the output to the zone displayed and move to the next available output.

**SELECT**  Press the SELECT button to turn the output either on or off (the output number will be displayed when turned on).

**FUNCTION**  Press the FUNCTION button to skip to the next function.

After all available outputs for the zone displayed are mapped, the display will automatically change to the next zone. After mapping the last zone or skipping to the next function, the following will appear in the display window:

B	A	N	N	E	R		M	E	S	S	A	G	E	?	
C	U	S	T	O	M		M	E	S	S	A	G	E		

To change the banner message, press the SET or SELECT buttons. If you don't want to change the banner message press the FUNCTION button.

If the SET or SELECT button was pressed, the following will appear in the display window:

^															

The “^” is pointing to the first character on the top line. Press the SET button to scroll one direction through the character set, or press the SELECT button to scroll the other direction. The entire alphabet, numbers and punctuation are included.

**SET**  Press the SET button to scroll through the character set in one direction.

**SELECT**  Press the SELECT button to scroll in the opposite direction.

**FUNCTION**  Press the FUNCTION button to enter the character displayed and to move to the next position.

After programming the top line (maximum 10 characters), continue this process for the bottom line and the initiating zones. To keep the initiating zones as “ZONE 1”, etc., press the FUNCTION button when they are displayed.

When finished with the last zone, the following will appear in the display window:

N	E	W		P	A	S	S	W	O	R	D	=	0	0	0
													^		

This allows the user to change the password. All panels are shipped from the factory with a password of 000.

**SET**  Press the SET button to set the displayed number and move to the next space.

**SELECT**  Press the SELECT button to scroll through the numbers.

**FUNCTION**  Press the FUNCTION button to skip this function.

When finished with this section, the following will appear in the display window:

P	U	S	H		P	R	O	G	R	A	M	M	I	N	G
S	W	I	T	C	H		B	A	C	K		U	P		

Quit by returning the programming switch to the left position. The panel is now ready for operation.

**Programming Summary**

- Examine History Buffer
- Set Time
- Enter Password
- Enable/Disable Initiating Zones
- Enable/Disable Output Zones
- System Mode - Normal/One Man Walktest
- Select Program - #0 thru #25

Custom Program (#0 only)

- Describe Initiating Zones 1 - 4
 

<b>Alarm Zones</b>	<b>Supervisory Zones</b>
Detection	Supervisory
Waterflow	Tamper
Linear Heat Detection	Low Air
Manual Release	Hi Air
	Low Air Alarm
- Describe Initiating Zone 5 (dedicated supervisory)
  - Supervisory
  - Tamper
  - Low Air
  - Hi Air
  - Abort
- Describe Initiating Zone 6
  - Supervisory
  - Tamper
  - Low Air
- Describe Output Zones
  - Alarm Indicating
  - Releasing
  - eAEROSOL
  - Supervisory Bell
  - Trouble Bell
    - 1) Releasing circuits: normal/cross-zoned
    - 2) Discharge time: 7, 8, 9, 10, 20 minutes or continuous
- Map Alarm Inputs to Outputs
- Put in Banner Message
- Put in Banner Message Bottom Line
- Put Zone Description for Each Initiating Zone
- Change Password
- Finished

**Installation Instructions**

Read the entire manual before attempting to install this panel

**NOTICE** This panel wiring should be installed and maintained in accordance with section 760 (Fire Protection Signaling Systems) and all other applicable sections of the National Electrical Code, all other applicable NFPA Code and Standards, local code and the authority having jurisdiction. Review the circuit parameters listed below before installing the panel.

**Canada Installations**

**CAUTION**

This panel wiring should be installed and maintained in accordance with CAN/ULC-S524M, (Standard for the Installation of Fire Alarm Systems), and all other applicable sections of the Canadian Electrical Code, all other applicable NFPA Code and Standards, local code and the authority having jurisdiction. Review the circuit parameters listed below before installing the panel.

**NOTICE** All wiring terminals support 14 to 22 AWG wire sizes. 18 AWG stranded or solid copper wire, (or wire size rated for the current carrying capacity of the input and output circuit application), with 300V, 85°C insulation is recommended.

**Wire checkout**

With all initiating devices and notification appliances installed and with the EOLR's in place, check the wires with an ohmmeter. Meter readings outside of the following will prevent normal operation.

From any wire to ground – more than 100K ohms.

Across the 2 wires on each Initiating zone – between 1.8K ohms and 5.4K ohms.

Across the 2 wires on each notification circuit – between 1.8K ohms and 23.9K ohms.

## Mounting Instructions

1) The unit should be mounted in a convenient location, approximately 5 ft. from the floor where it will be accessible for testing and servicing.

### WARNING

Removal of this false front exposes electrical components at potentially hazardous voltages and should be performed by qualified personnel only.

2) The main circuit board module should be removed before attempting to mount the cabinet. Disconnect the AC power from TB201. To remove the module, remove the two screws holding the chassis to the cabinet. Lift the module upwards, approximately 1/2", in order to clear the cross-beam of the cabinet on which the module rests. Remove the module and set aside.

3) The PFC unit may be surface mounted or semi-flush mounted using the optional trim bezel. (See drawing for installation of bezel on page 92). For semi-flush installations mount the housing so that the front edge protrudes 1" from the finished wall surface. After all conduits and wiring are in place and the wall surface is completely finished, slide the trim bezel in place and fasten with 4 #6-32 x 1/4" machine screws and nuts.

4) Install all required conduits, external wiring and devices and make all connections that are external to the panel. Replace the module. With the AC power still turned off at the circuit breaker panel, connect the AC hot, neutral and ground wires to the terminal block TB201 as shown on the connection drawing. (See connection drawings on page 88)

5) Connect all the other wiring to the terminals as shown in the connection drawings. Turn the AC power on and connect the standby batteries with the cable provided, polarity must be observed.

6) Replace false front panel and secure with mounting screws, taking care to not damage LED annunciator module cable.

7) The operation of the complete system should be verified as outlined in the test procedure section.

## PFC-4410RC False Front Removal/Assembly Drawing

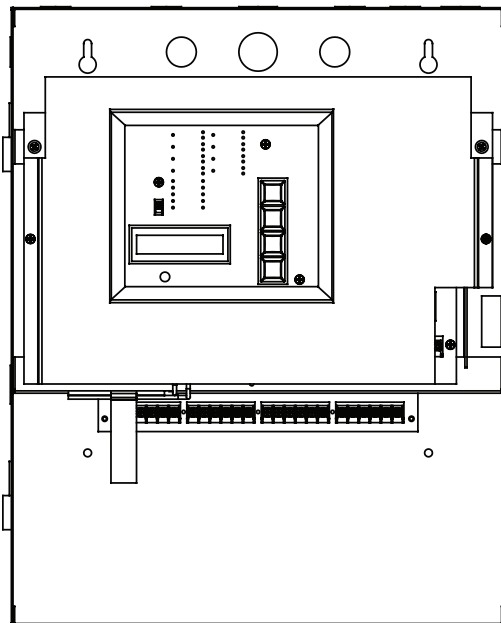

DWG# 3550-15

**Inactive Circuits**

All inactive initiating device circuits and indicating appliance circuits must have the end-of-line resistor on the panel terminal.

**Operating Instructions Form**

Fill in the name, address and telephone number of the servicing agency on the appropriate instruction sheet provided and frame and place adjacent to control panel at eye level.

**Battery Size Calculations**

To use Calculation Table:

- 1) List in column #1 all devices used in the system, include all modules, bells, horns, door holders, and smoke detectors (see table #1 or manufacturers specifications).
- 2) List in column #2 the quantity of each device.
- 3) List in column #3 the standby current of each device (exclude all alarm signal indicating devices).
- 4) List in column #5 the alarm current of each device.
- 5) For each line, multiply the figure in column #2 by the figure in column #3 and enter the product in column #4. Then multiply the figure in column #2 by the figure in column #5 and enter the product in column #6.
- 6) Add the figures in columns #3 and #6, enter the sums in the appropriate Total mA box.
- 7) Convert these figures from milliamperes to amperes by multiplying by 0.001, enter the product in the appropriate Total A box.
- 8) Multiply the standby total amperes by required time in hours from table 2.
- 9) Divide the alarm total amperes by 12 (5 mins.).
- 10) Add the standby AH and the alarm AH and divide this sum by 0.80 (efficiency factor). Select a battery that has an AH rating above this figure but not less than 6.5AH.

**Battery Size Requirements And Maintenance**

These panels require a 24 volt gel-cell battery for proper operation. 24 hours of standby power is required for Local Systems and Central Station (NFPA-72).

The chart below will assist you in selecting the proper size battery: (Does not include LED Annunciator)

No. of Smoke Detectors	No. of Bells (100mA each)	Auxiliary Power Requirements	Standby Hours Required	Battery Size/Part No. (2 Req.)
0-100	0-10	0-25mA	24	8AH/5130084/BT 80
0-100	0-10	0-30mA	90	18AH/5130086/BT 180

**NOTICE**

Maximum required battery size for UL Listings is 12AH. FM and others may require more than 90 hours of standby time and may use larger batteries. Batteries rated above 18AH require a separate battery cabinet (Potter stock number 1000015). Mark the purchase date on the batteries. Test the batteries at least semi annually according to the battery test methods in NFPA72 or the battery manufacturers instructions. Replace the batteries if they either fail the test or after four years of use.



**Current Requirements: Table 1**

Module/Device	Standby mA*	Alarm mA*
PFC-4410RC	121	274
RA-4410RC	11	13

\*Add 23 mA plus current requirement of all devices connected for each output programmed as Trouble Bell

\*\*Includes one zone short circuit current.

**Secondary Power Supply Requirements: Table 2**

Service Use	Standby Time	Alarm Time
NFPA 72		
• Central Station (PPU)	24 hrs.	5 mins.
• Local	24 hrs.	5 mins.
FMRC 1011 and 1012, Deluge and Pre-action Systems	90 hrs.	10 mins.
Where requested by FM or others.		
90 Hours is not a UL requirement.		

**Calculation Table**

1	2	3	4	5	6
Module/Device	Quantity	Standby mA Per Unit	Total Standby Current	Alarm mA Per Unit	Total Alarm Current
Total mA				Total mA	
Convert to A			x 0.001	Convert to A	
Total A				Total A	
Multiply by hours from table 2			x ____	5 min/12 or 10 min/6	
Total Standby AH				Total Alarm AH	
				+ Total Standby AH	
				Total AH	
				Efficiency Factor	
				÷ 0.80	
				Required AH	

Use a battery with a higher AH rating than Required AH

### Typical 2 Wire Detector Connection Drawing

Base wiring for Potter model PS-24 Photoelectric Detectors.

### Typical Style B (Class B) Wiring Using SB-46 Base

(These bases can be used in style B or Style D wiring)

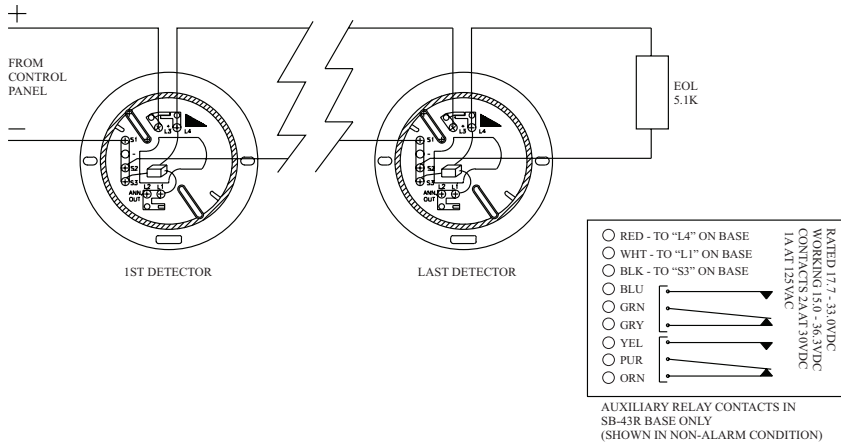

### Typical Style D (Class A) Wiring

(These bases can be used in style B or style D wiring)

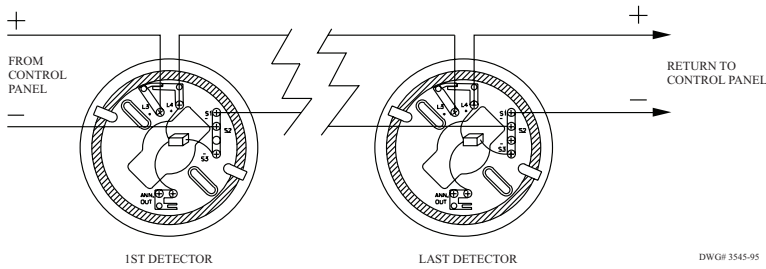

### Typical 4-Wire Wiring

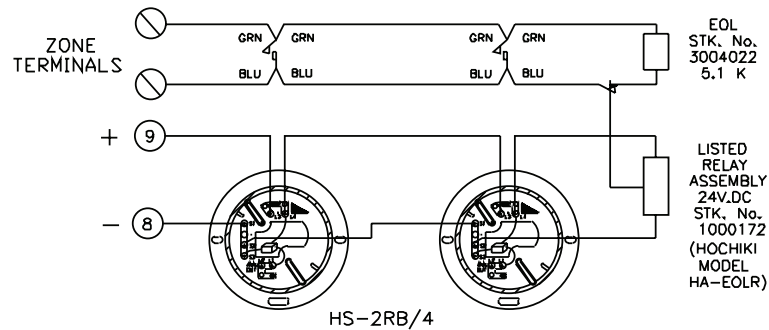

DWG. #3521-5

# PFC-4410RC Connection Drawing

For additional information see text in this manual Identifier A

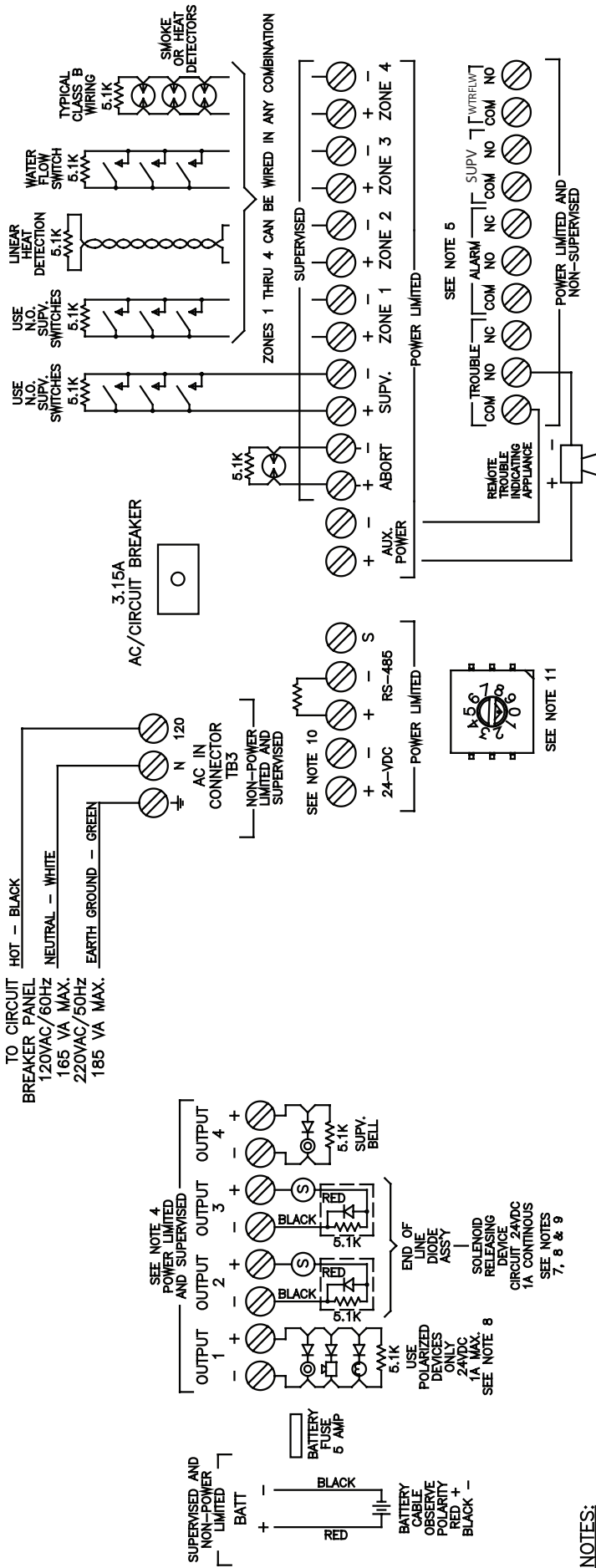

- NOTES:**
- 1.) USE ONLY SMOKE DETECTORS THAT ARE LISTED IN COMPATIBILITY LIST, ON INSIDE OF DOOR.
  - 2.) LEAVE END OF LINE RESISTORS ON INACTIVE CIRCUITS.
  - 3.) ALL CIRCUITS POWERED BY THIS CONTROL PANEL ARE SUPERVISED AND POWER LIMITED.
  - 4.) COMBINED LOAD OF ALL EXTERNAL DEVICES INCLUDING INDICATING AND RELEASING APPLIANCES IS NOT TO EXCEED 2.5 AMPS. REGULATED 24VDC MAXIMUM RMS VOLTAGE RANGE LIMIT, 16-33 VDC.
  - 5.) COMMON RELAY CONTACTS RATED 3A 30VDC RESISTIVE. COMMON RELAY CONTACTS ARE SHOWN IN THE NORMAL CONDITION. NOT TO BE USED FOR MOTOR LOADS OR PILOT DUTY APPLICATION.
  - 6.) AUXILIARY POWER FOR LIMITATIONS, SEE SECTION "BATTERY SIZE REQUIREMENTS" COMBINED LOAD ON THESE TERMINALS NOT TO EXCEED 200ma MAX. SEE SECTION ON "COMPATIBILITY DATA".
  - 7.) FOR MAX. CURRENT, RESISTANCE, AND MIN. BATTERY VOLTAGE, SEE SECTION ON "RELEASING CIRCUIT". FOR LIST OF COMPATIBLE SOLENOIDS AND VALVES, SEE SECTION ON "EXTINGUISHING AGENT CONTROL VALVE COMPATIBILITY DATA".
  - 8.) POLARITY SHOWN ON BELL AND RELEASING CIRCUITS IS FOR ACTIVE ALARM CONDITION
  - 9.) END OF LINE DIODE ASSEMBLY (PART #3005012) MUST BE LOCATED AT SOLENOID VALVE LOCATION.
  - 10.) POWER AND COMMUNICATION FOR RA-4410-RC ANNUNCIATOR. SHIELDED CABLE MUST BE USED FOR THE RS-485 CONNECTION. MAXIMUM 2000' WITH 22 AWG OR 4000' WITH 20 AWG WIRE. REMOVE 120 OHM RESISTOR FROM PANEL AND PLACE ON LAST ANNUNCIATOR.
  - 11.) ROTARY SWITCH FOR REMOTE ANNUNCIATOR. SET SWITCH TO NUMBER OF ANNUNCIATORS CONNECTED (4 MAX).
  - 12.) RESETTABLE POWER FOR 4-WIRE SMOKE DETECTOR SPECIAL APPLICATION 24VDC 200 mA
  - 13.) WATERFLOW RELAY ONLY TRANSFERS UPON ACTIVATION OF ZONES PROGRAMMED AS WATERFLOW

## 2-Wire Smoke Detector Compatibility Data

Smoke Detector Compatibility Identifier "A"

### System Sensor (Brk) (Max. No. Of Detectors Per Zone Is 20)

Det. Model	Identifier	Base Model	Identifier
1400*	A	N/A	N/A
2400*	A	N/A	N/A
2400TH*	A	N/A	N/A
2W-B	A	N/A	N/A
2WT-B	A	N/A	N/A
2WTR-B	A	N/A	N/A

### Detection Systems (Max. No. Of Detectors Per Zone Is 25)

Det. Model	Identifier	Base Model	Identifier
DS250	A	MB2W/MB2WL	A
DS250TH	A	MB2W/MB2WL	A
DS250HD	A	MB2W/MB2WL	A

### Esl (Max. No. Of Detectors Per Zone Is 25)

Det. Model	Identifier	Base Model	Identifier
611U	S10	601U	S00
611UD	S10	601U	S00
611UT	S10	601U	S00
612U	S10	601U	S00
612UD	S10	601U	S00
613U5	S10	601U	S00
611UD	S10	609U10	S00
612UD	S10	609U10	S00
425C	S10	N/A	N/A
425CT	S10	N/A	N/A

### Hochiki (Max. No. Of Detectors Per Zone Is 25)

Det. Model	Identifier	Base Model	Identifier
SLR-24*	HD-3	HSC-221R	HB-71
		HSB-221	HB-54
		HSB-221N	HB-54
		NS6-221	
		NS4-221	
		NS6-220	HB-3
SLR-24H*	HD-3	HSC-221R	HB-71
		HSB-221	HB-54
		HSB-221N	HB-54
		NS6-221	
		NS4-221	
		NS6-220	HB-3
SIJ-24*	HD-3	HSC-221R	HB-71
		HSB-221	HB-54
		HSB-221N	HB-54
		NS6-221	
		NS4-221	
		NS6-220	HB-3

### Fenwal (Max. No. Of Detectors Per Zone Is 25)

Det. Model	Identifier	Base Model	Identifier
CPD-7051*	I51FE1	2-WIRE	FE51A
PSD-7155*	P55FE1	2WRLT	FE52A
PSD-7156*	P56FE1	2WRB	FE55A

All of the above Fenwal detectors and bases can be used in any combination

Retrofit Base Adaptor 70-501000-003, Identifier MAFE1 (for series 70-201000 Bases, Models -001, -002, -003 and -005)  
 Duct Housing with Detector Base DH-51, Identifier DH22FE5 (for CPD-7051 and PSD-7155 detectors only)

### Potter (Max. No. Of Detectors Per Zone Is 25)

Det. Model	Identifier	Base Model	Identifier
PS-24*	HD-3(HOCHIKI)	SB-46	HB-71(HOCHIKI)
		SB-93	HB-54(HOCHIKI)
PS-24H	HD-3(HOCHIKI)	SB-93	HB-3 (HOCHIKI)
		SB-46	HB-71(HOCHIKI)
			HB-54(HOCHIKI)

## NOTICE

Only one detector can be supported in alarm per zone.

If using a mix of System Sensor and other smoke detectors, a maximum of 20 detectors shall be permitted.

Sync Module Compatibility - Panel is compatible with the following synchronization modules:

Amseco #SMD10-3A, Gentex #AVSM, System Sensor #MDL, Wheelock #DSM12/24



\*UL and ULC Listed

### Wire Routing for PFC-4410RC

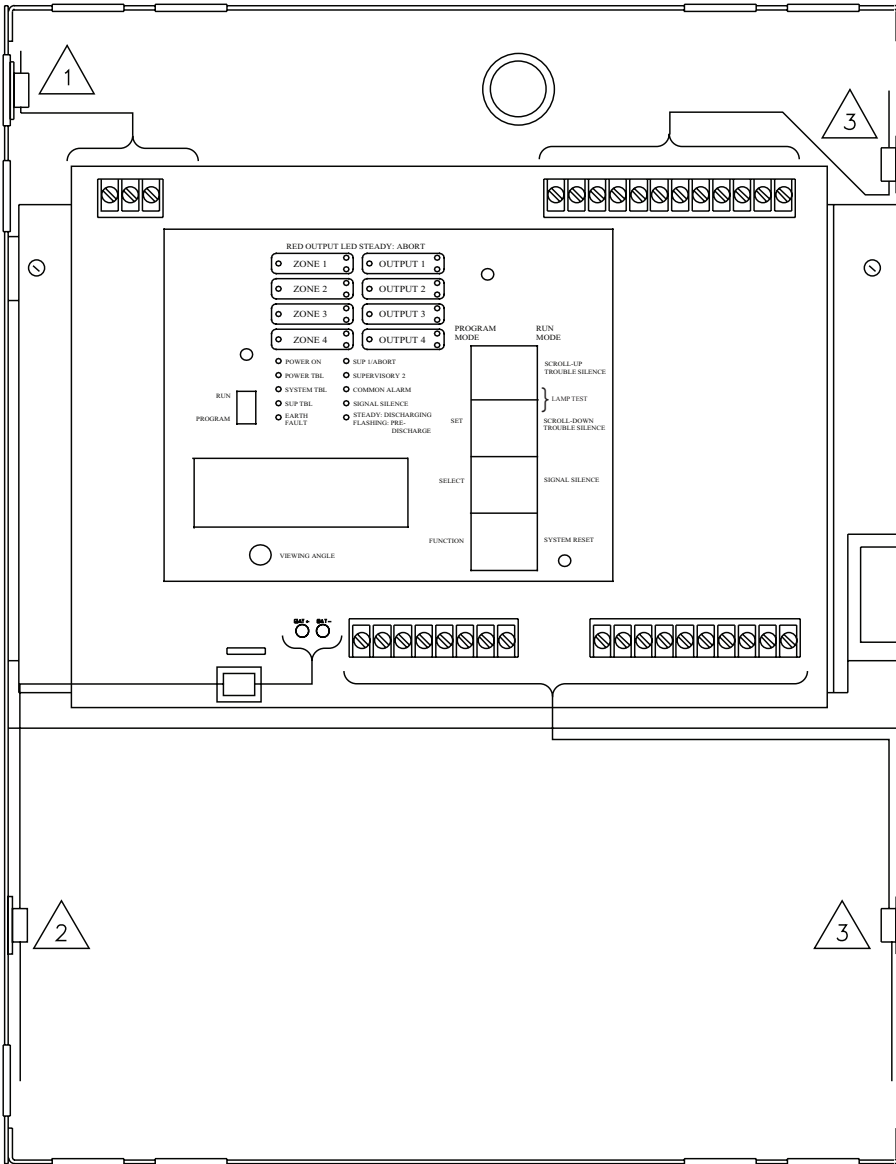
(\*Shown with false front removed)



DWG# 3550-16

-  1 Power inputs
-  2 Battery leads
-  3 Using the cable clamps provided, route all other wiring away from power input wiring.

### **NOTICE**

All field installed wiring connected to this panel must maintain a spacing of 1/4" between all electric light, power, class 1 or non-power limited fire protective signaling conductors.

**NOTICE****NEC Section 760-54**

Installation of Conductors and Equipment.

- (a) Separation from Electric Light, Power, Class 1, and NPLFA Circuit Conductors.
- (1) In Cables, Compartments, Enclosures, Outlet Boxes, or Raceways. Power-limited circuit conductors shall not be placed in any cable, compartment, enclosure, outlet box, raceway, or similar fitting containing conductors of electric light, power, Class 1, or nonpower-limited fire alarm circuit conductors.

Exception No. 1: Where the conductors of electric light, power, Class 1, or nonpower-limited fire alarm circuit conductors are separated by a barrier from the power-limited fire alarm circuits. In enclosures, power-limited fire alarm circuits shall be permitted to be installed in a raceway within the enclosure to separate them from Class 1, electric light, power, and non power-limited fire alarm circuits.

Exception No. 2: Conductors in compartments, enclosures, device boxes, outlet boxes, or similar fittings, where electric light, power, Class 1, or nonpower-limited fire alarm circuit conductors are introduced solely to connect to the equipment connected to power-limited circuits to which the other conductors are connected, and

- a. The electric light, power, Class 1, and nonpower-limited fire alarm circuit conductors are routed to maintain a minimum of 0.25 in. (6,35mm) separation from the conductors and cables of power-limited fire alarm circuits, or
- b. The circuit conductors operate at 150 volts or less to ground and also comply with one of the following:
  1. The fire alarm power-limited circuits are installed using Types FPL, FPLR, FPLP or permitted substitute cables, provided these power-limited cable conductors extending beyond the jacket are separated by a minimum of 0.25 in. (6,35mm) or by a nonconductive sleeve or nonconductive barrier from all other conductors, or
  2. The fire alarm power-limited circuit conductors are installed as nonpower-limited fire alarm circuits in accordance with Section 760-25.

Exception No. 3: Conductors entering compartments, enclosures, device boxes, outlet boxes, or similar fittings, where electric light, power, Class 1, or nonpower-limited fire alarm circuit conductors are introduced solely to connect to the equipment connected to power-limited fire alarm circuits or to other circuits controlled by the fire alarm system to which the other conductors in the enclosure are connected. If the conductors must enter an enclosure that is provided with a single opening, they shall be permitted to enter through a single fitting (such as a tee) provided the conductors are separated from the conductors of the other circuits by a continuous and firmly fixed nonconductor, such as flexible tubing.

### Connection Procedure for Battery Charging Current and Voltage

- 1) To measure the battery charging voltage:  
Place a voltmeter across the battery terminals as shown in FIG. 4
- 2) To measure the battery charging current:  
Place a current meter in series with the battery terminals as shown in FIG. 5.

Fig. 4

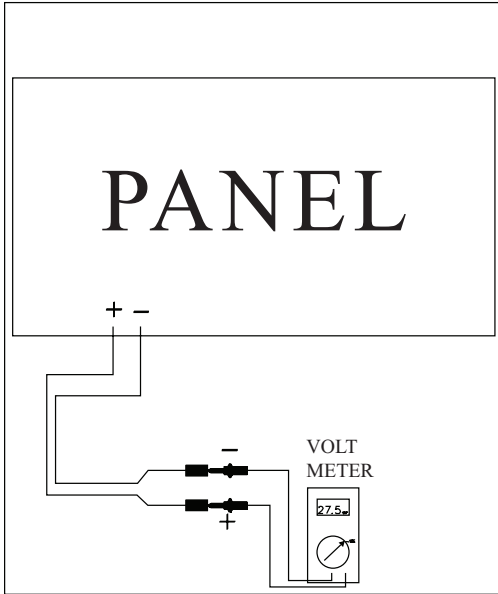
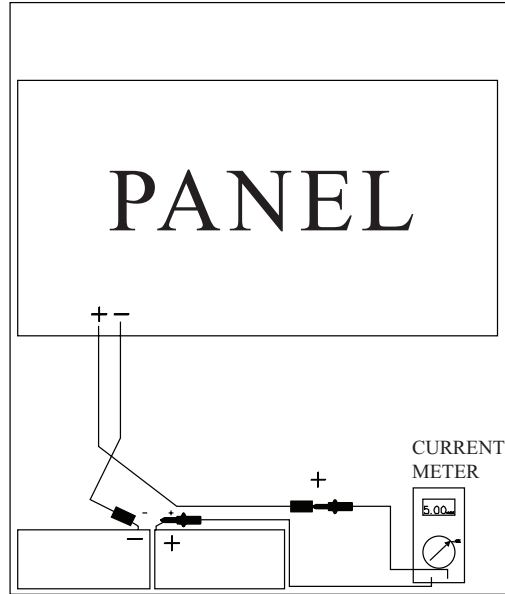
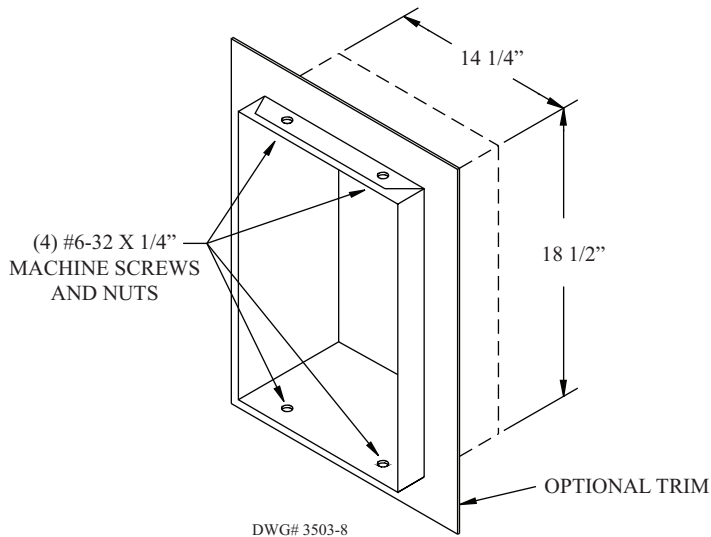

Fig. 5



DWG# 3527-9

### Installation Of Bezel For Semi-flush Installations





### Connection Drawing for Central Station and Remote Station Operation PFC-4410RC to any UL listed Digital Alarm Communicator Transmitter (DACT)

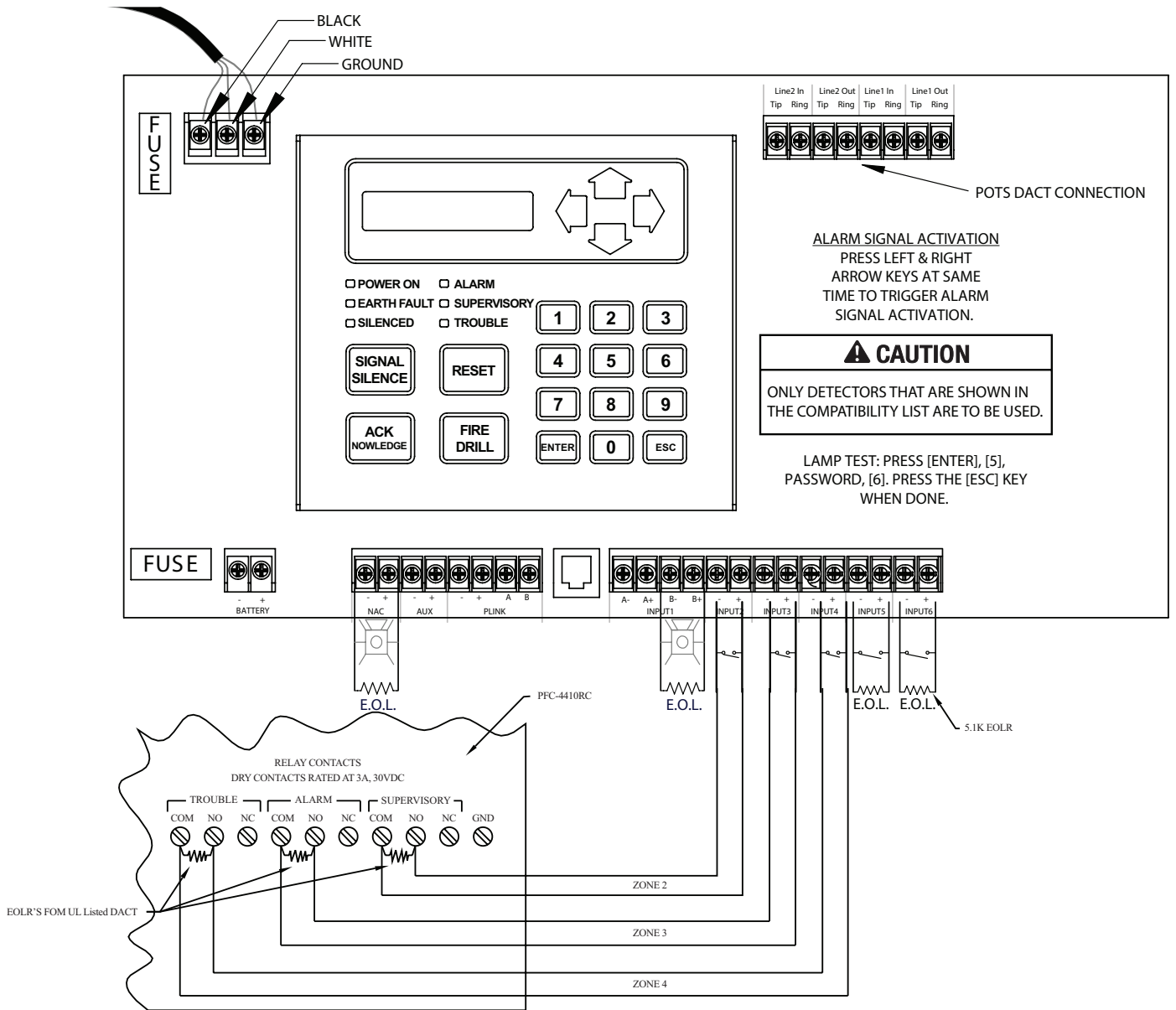

**Annex A: 4-Wire Smoke Detectors/Devices**

<b>Smoke Detector</b>	<b>Detector Type</b>	<b>Standby Current (mA)</b>	<b>Alarm Current (mA)</b>
Potter PS-24*	Photoelectric	.045	150
Potter PS-24H*	Photoelectric/Heat	.045	150
DSD-P	Photoelectric Duct	.390	8
Hochiki SLR-835*	Photoelectric	.055	150
Hochiki SLR-835H	Photoelectric/Heat	.045	150
Hochiki SLR-24V*	Photoelectric	.045	150
Hochiki SLR-24VN*	Photoelectric	.045	150
Hochiki SIJ-24*	Ionization	.040	150
Hochiki DCD-135/190	Heat	.040	150
Hochiki DH-98	Photoelectric Duct	.390	8
Hochiki SPB-24	Beam	.25	**
Fenwal CPD-7021 (w/70-201000-005 base)	Ionization	0.10	**
Fenwal PSD-7125	Photoelectric	0.10	**
Fenwal PSD-7126 (w/70-201000-005 base)	Photoelectric	0.10	**
Gentex 824	Photoelectric	0.50	**
Gentex 824T	Photoelectric	0.50	**
Gentex 824CP	Photoelectric	0.50	**
Gentex 824CPT	Photoelectric	0.50	**
System Sensor B112LP	Base	0.12	36
System Sensor B114LP	Base	**	**
System Sensor B404B	Base	**	**
System Sensor DH100ACDC	Photoelectric	0.15	0.70
System Sensor DH100ACDCLP	Photoelectric	0.15	0.70
System Sensor DH100ACDCLWP	Photoelectric	0.15	0.70
System Sensor DH400ACDCI	Ionization Duct	25	95
System Sensor DH400ACDCP	Photoelectric Duct	25	95
System Sensor 1112/24/D	Ionization	0.05	50
System Sensor 1424	Ionization	0.10	41
System Sensor 1451 (w/B402B base)	Ionization	0.10	39
System Sensor 2112/24ATR	Photoelectric	0.50	60/70
System Sensor 2112/24AITR	Photoelectric	0.50	60/70
System Sensor 2112/24/D	Photoelectric	0.05	50
System Sensor 2112/24R	Photoelectric	0.50	60/70
System Sensor 2112/24TR	Photoelectric	0.50	60/70
System Sensor 2112/24T/D	Photoelectric w/135° thermal	0.05	50
System Sensor 2112/24TSRB	Photoelectric w/135° thermal	15	45
System Sensor 2312/24TB	Photoelectric	0.12	50
System Sensor 2424	Photoelectric	0.10	41
System Sensor 2424TH	Photoelectric	0.10	41
System Sensor 2451	Photoelectric	0.10	39
System Sensor 2451TH (w/B402B base)	Photoelectric	0.10	39

System Sensor 2W-MOD	Loop test/maint. mod.	30	50
System Sensor 4W-B (12/24V)	Photoelectric	.05	23
System Sensor 4WT-B (12/24V)	Photoelectric I w/therm	.05	23
System Sensor 4WTA-B (12/24V)	I Photo w/therm/sounder	.05	35
System Sensor 4WTR-B (12/24V)	I Photo w/therm/relay	.05	35
System Sensor 4WTAR-B (12/24V)	I Photo w/therm/sounder/relay	.05	50
System Sensor 4WITAR-B (12/24V)	I Photo w/isolated therm/sounder/relay	.05	50
System Sensor 2WMOD2	I Loop test/maint. mod.	.05	**
System Sensor RRS-MOD	I Reversing relay/sync module	.05	**
System Sensor 6424	Projected beam	10	28.4
System Sensor Beam 1224(S)	Projected beam	17	38.5
* Using Hochiki base HSC-4R			
**NOTE: Contact manufacturer for current draws			

Annex B: Product Datasheets of Optional Equipment



**ARM-1**  
AUXILIARY RELAY MODULE

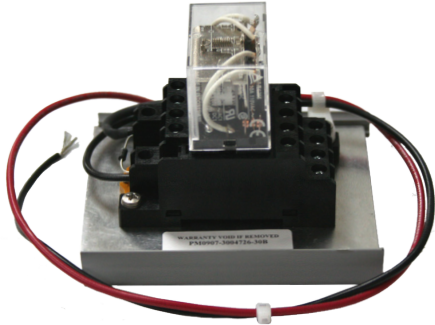

**UL Listed:** For use with the PFC-4410RC Series  
**Dimensions:** 3 1/4" X 3 1/4" X 4"  
**Weight:** .315 lb.  
**Assembly:** Socketed relay in plastic mounting track  
**Power Requirements:** 40mA at 24VDC  
**Contact Ratings:**  
 Each relay has 4PDT contacts,  
 Rated at 10 amps resistive,  
 24VDC

**Stock number:** 3004726

When the ARM-1 is used the additional power required for this relay module must be subtracted from the total circuit current available. The ARM-1 Auxiliary Relay Module is a non-supervised 4PDT Relay

designed to be activated by 24VDC Indicating and/or Releasing, polarity reversing circuits. The module can be used for fan shutdown, door release, elevator recall, etc.

**Wiring**

18" WIRE LEADS  
FURNISHED FOR  
RELAY COIL

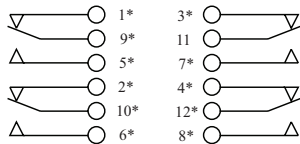
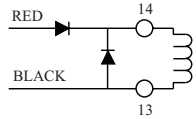

\* NUMBERS REFER TO  
SOCKET TERMINALS  
NOT RELAY PINS.  
RELAY SHOWN DE-ENERGIZED

DWG# 1134-1

**Placement In PFC-4410RC Series Control Unit**

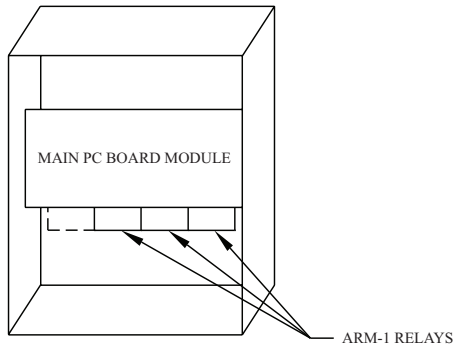

**ARM-1/PFC-4410RC Installation Hook-Up Diagram**

All relays shown in non-activated condition

CONNECT ARM-1 TO  
OUTPUT CIRCUIT

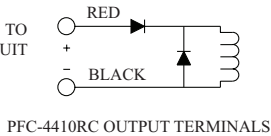

PFC-4410RC OUTPUT TERMINALS

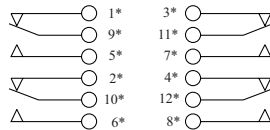

DWG# 1134-2

**Notes:**

- \* Numbers refer to socket terminals not relay pins.
- Auxiliary relay operation is determined by programming of the PFC-4410RC panel. Consult the appropriate manual for further information.



## ARM-2 AUXILIARY RELAY MODULE

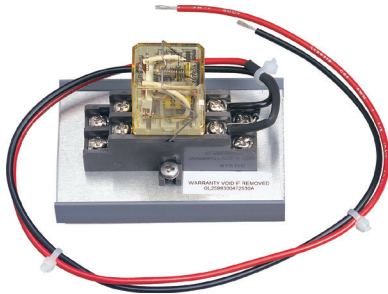

**UL Listed:** For use with the PFC-4410RC Series  
**Dimensions:** 2 1/4" x 3 1/2" x 3"  
**Weight:** .315 lb.  
**Assembly:** Socketed relay in plastic mounting track  
**Power Requirements:** 40mA at 24VDC  
**Contact Ratings:**  
 Each relay has DPDT contacts,  
 Rated at 7.5 amps resistive,  
 120VAC, 30VDC

**Stock number:** 3004725

The ARM-2 Auxiliary Relay Module is a UL listed option when factory installed in the Potter PFC-4410RC Series. When the ARM-2 is used the additional power required for this relay module must be subtracted from the total circuit current available. See PFC-4410RC Manual #5403550. The ARM-2 Auxiliary Relay Module is a non-supervised DPDT Relay designed to be activated

by 24VDC Indicating and/or Releasing, polarity reversing circuits. The module can be used for fan shutdown, door release, elevator recall, etc.  
*Note: One to four ARM-2 modules in the PFC-4410RC series may be utilized to provide multiple auxiliary functions.*

### Wiring

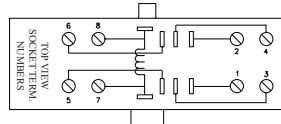
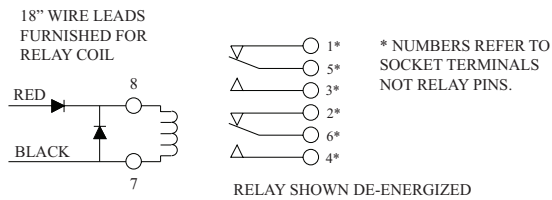

DWG# 977-1

### Placement In PFC-4410RC Series Control Unit

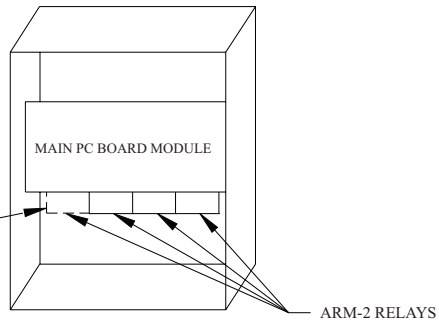

### ARM-2/PFC-4410RC Installation Hook-Up Diagram

All relays shown in non-activated condition

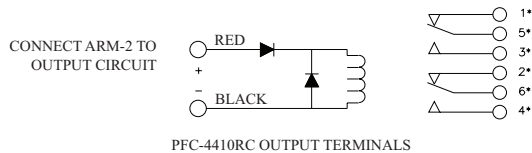

Notes:

1. \* Numbers refer to socket terminals not relay pins.
2. Auxiliary relay operation is determined by programming of the PFC-4410RC Series panel. Consult the appropriate manual for further information.



**CA2Z**  
**CLASS A INITIATING**  
**DEVICE MODULE**

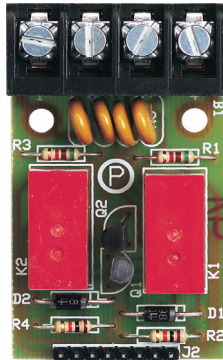

**UL Listed:** Option for use with the PFC-4410RC Series  
**Transient Protected**  
**Built In 5.1k End Of Line Resistor**  
**PC Board Assembly:** Mounts to PFC-4410RC Panel stand-offs  
**Stock No.** 3006013

The Model CA2Z Class A Module is designed to be used with the PFC-4410RC Fire Control Releasing Panel to convert from two (Class B) initiating device circuits to two (Class A) circuits.

The module is to be mounted in the upper right hand corner of the panel. Connection to the panel is made via the 8 pin header mounted on the back side of the CA2Z.

**Mounting**

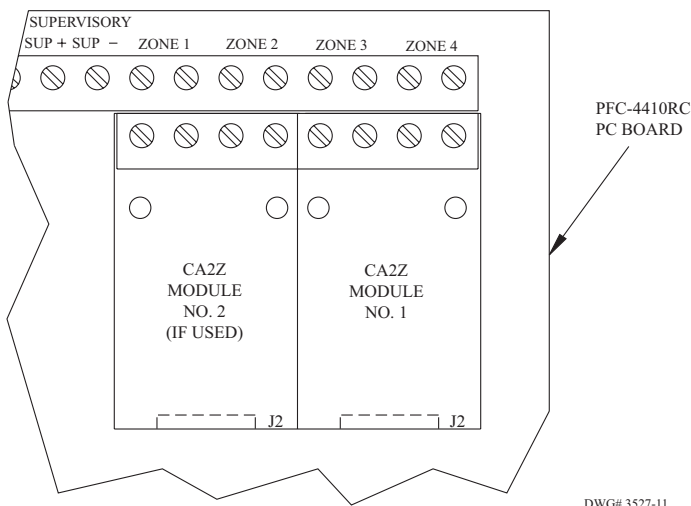

**Typical Wiring**

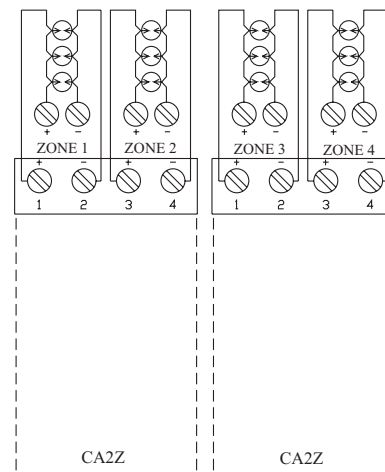



## CAM CLASS A INDICATING APPLIANCE CIRCUIT MODULE

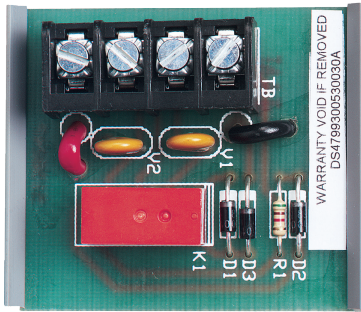

UL LISTED: OPTION FOR USE WITH THE PFC-4410RC SERIES TRANSIENT PROTECTED POWER REQUIREMENTS IN ALARM: APPROXIMATELY 25 MA AT 24VDC FROM CONTROL PANEL INDICATING APPLIANCE CIRCUIT. BUILT IN, POLARIZED, 5.1K END OF LINE RESISTOR

Stock number: 3005300

The Model CAM Class A Module is designed to be used with the PFC-4410RC Fire Control Releasing Panel to convert a single (Class B) indicating appliance circuit to a (Class A) circuit (one module is required for each indicating appliance circuit). After installing the

CAM, the indicating circuit should be activated to ensure proper operation and connections. The module is provided with double sided foam tape and should be mounted in the area below the main circuit module so that the terminals are accessible.

### Mounting

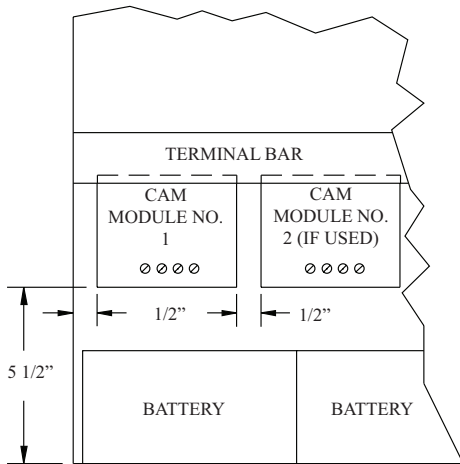

### Typical Wiring

