

UTILITY RACK

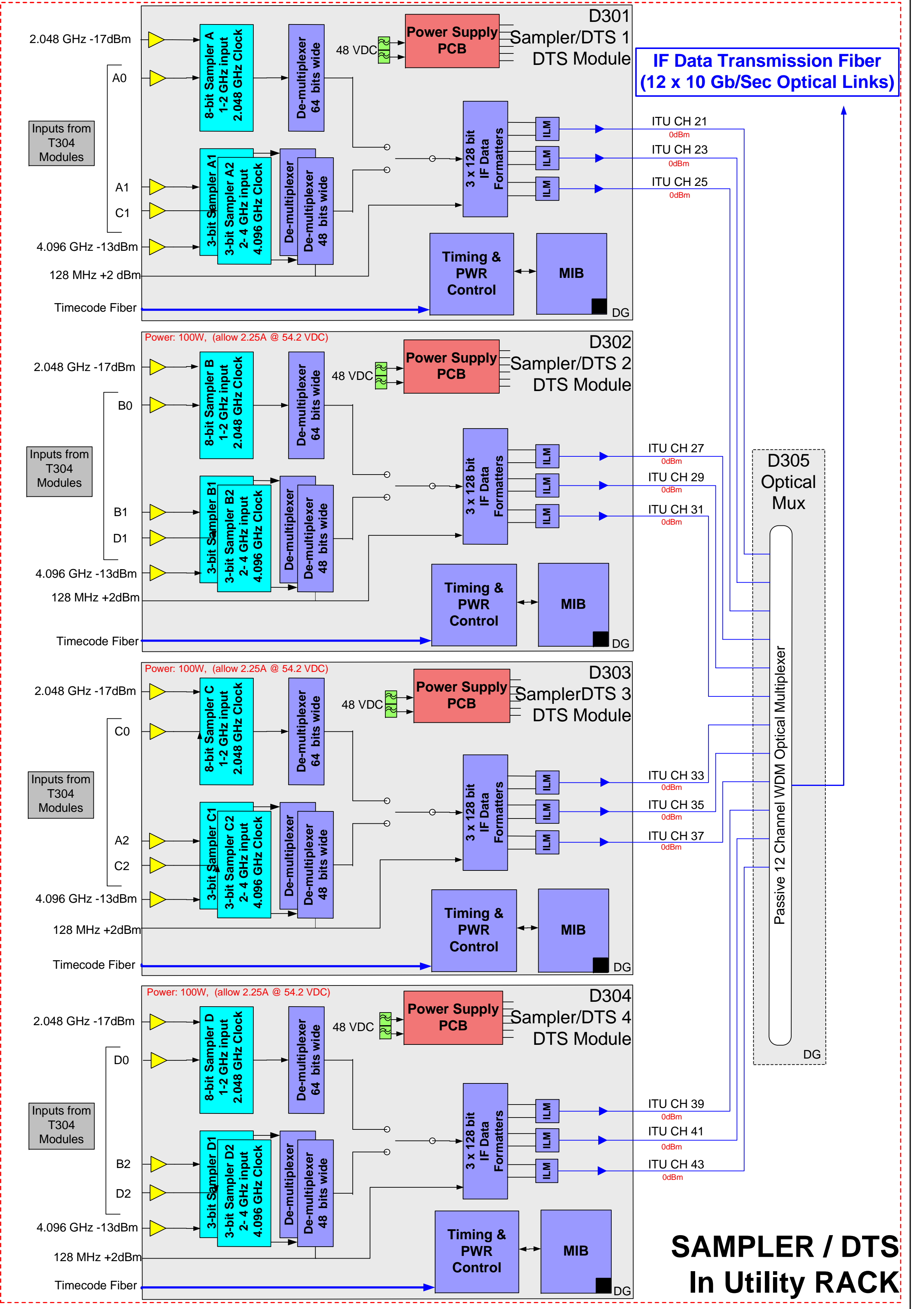

■ = MCB Fiber Ethernet Connection Point

Changes made 18 Oct 2013, JJ :  
- Added D306 VLITE Module  
- Added Optical Splitter for D306 Timecode  
- Added Splitter to L300 for 1.024 GHz Clock to D306  
- Added Splitters to Low Band Receiver Output for D306  
- Removed F14 Modules (no longer needed)  
- Modified F320 for Low Band Receiver Control (renamed F318)  
- General drawing cleanup.

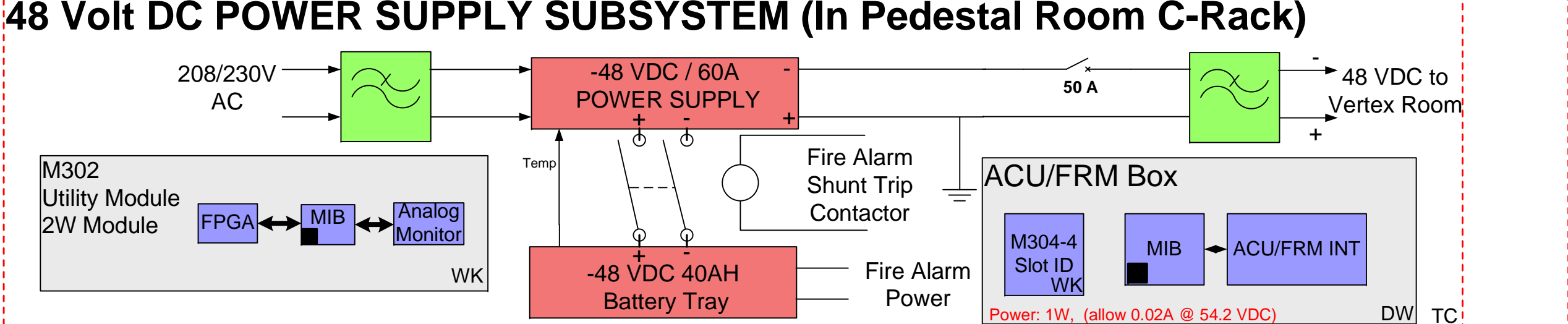
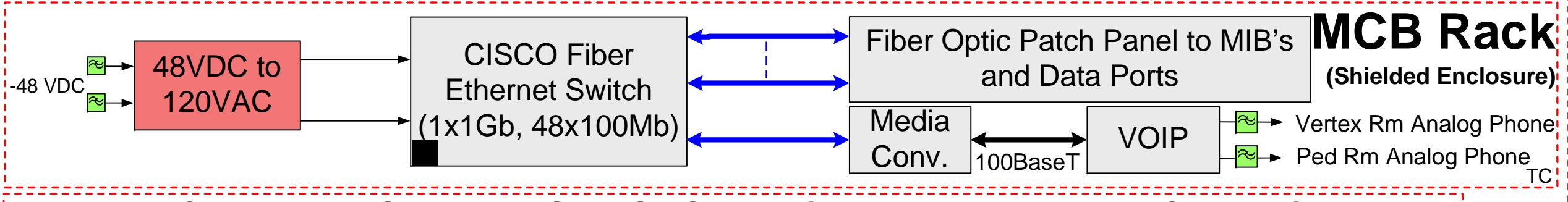
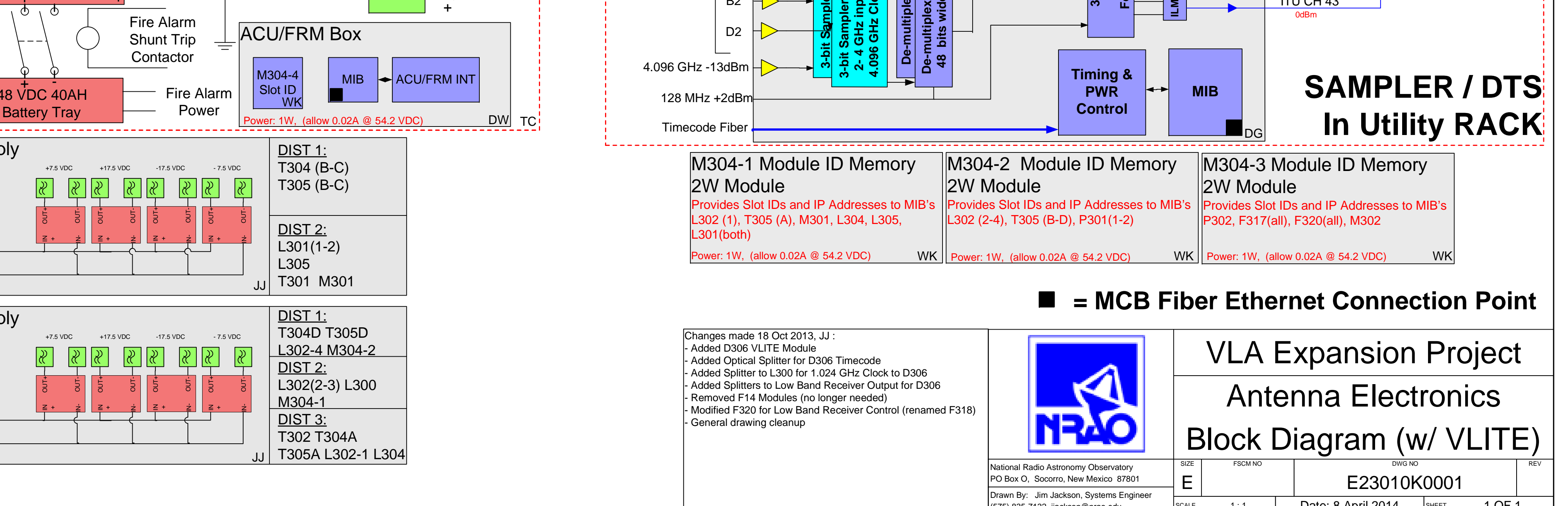
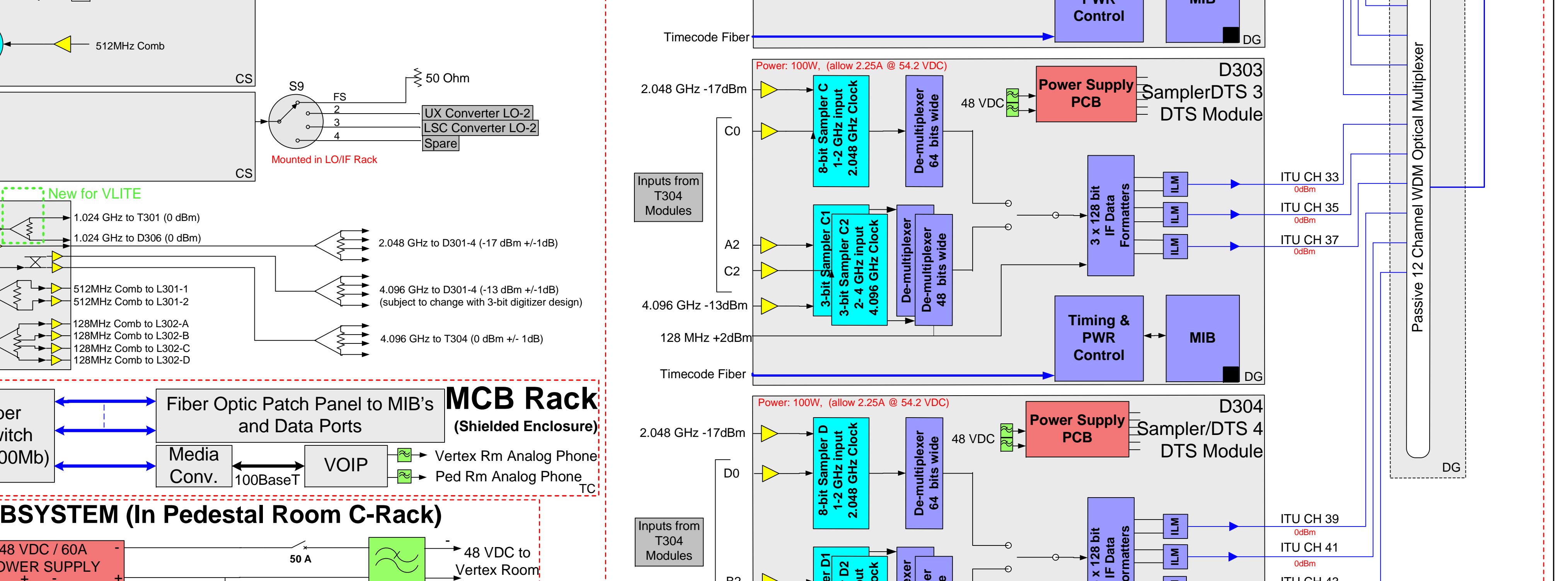
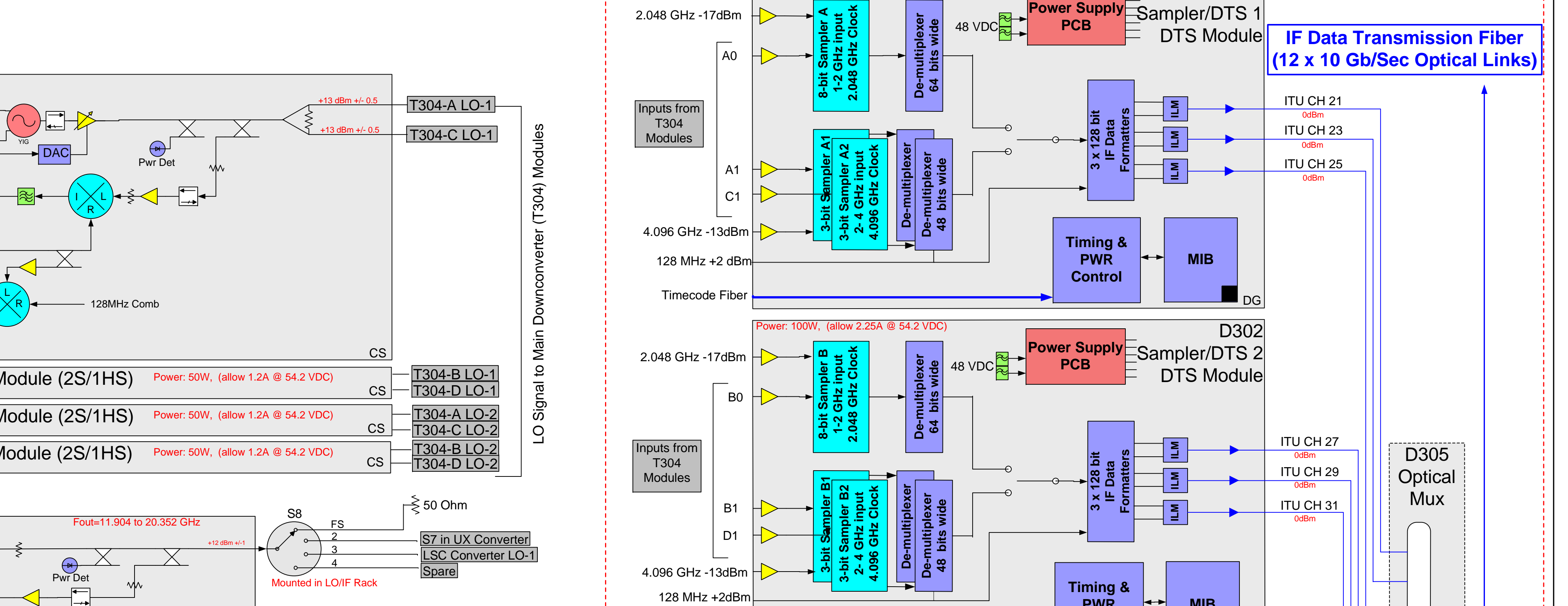
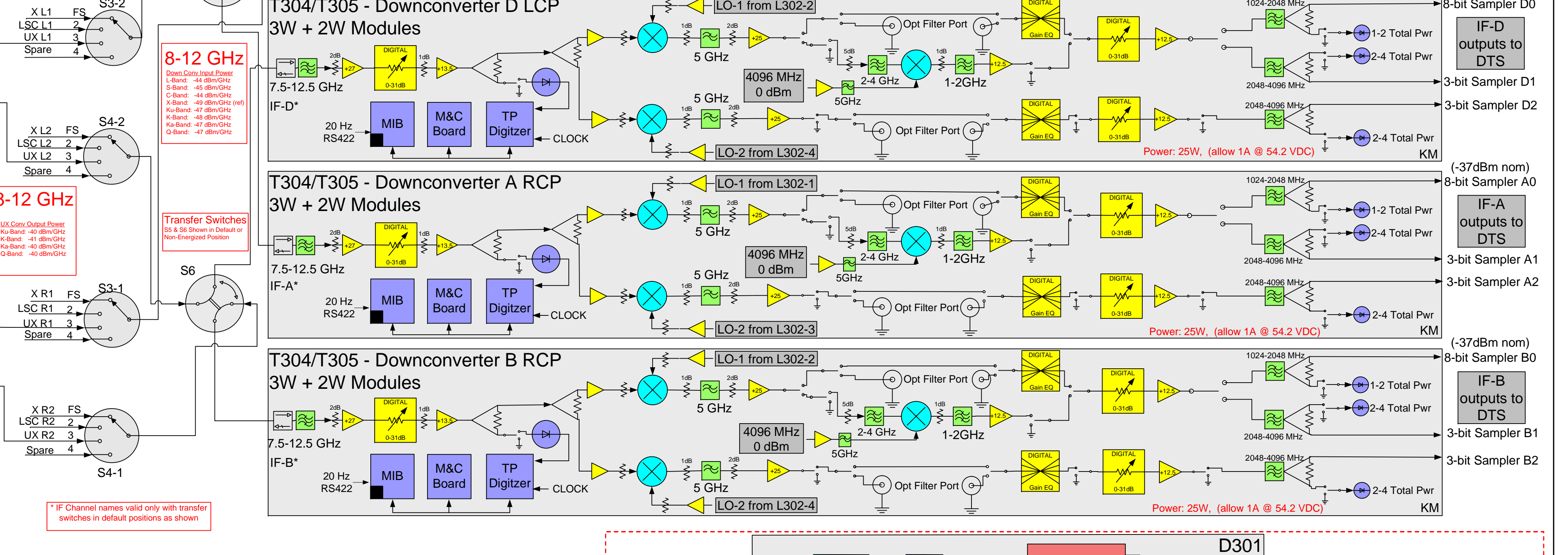
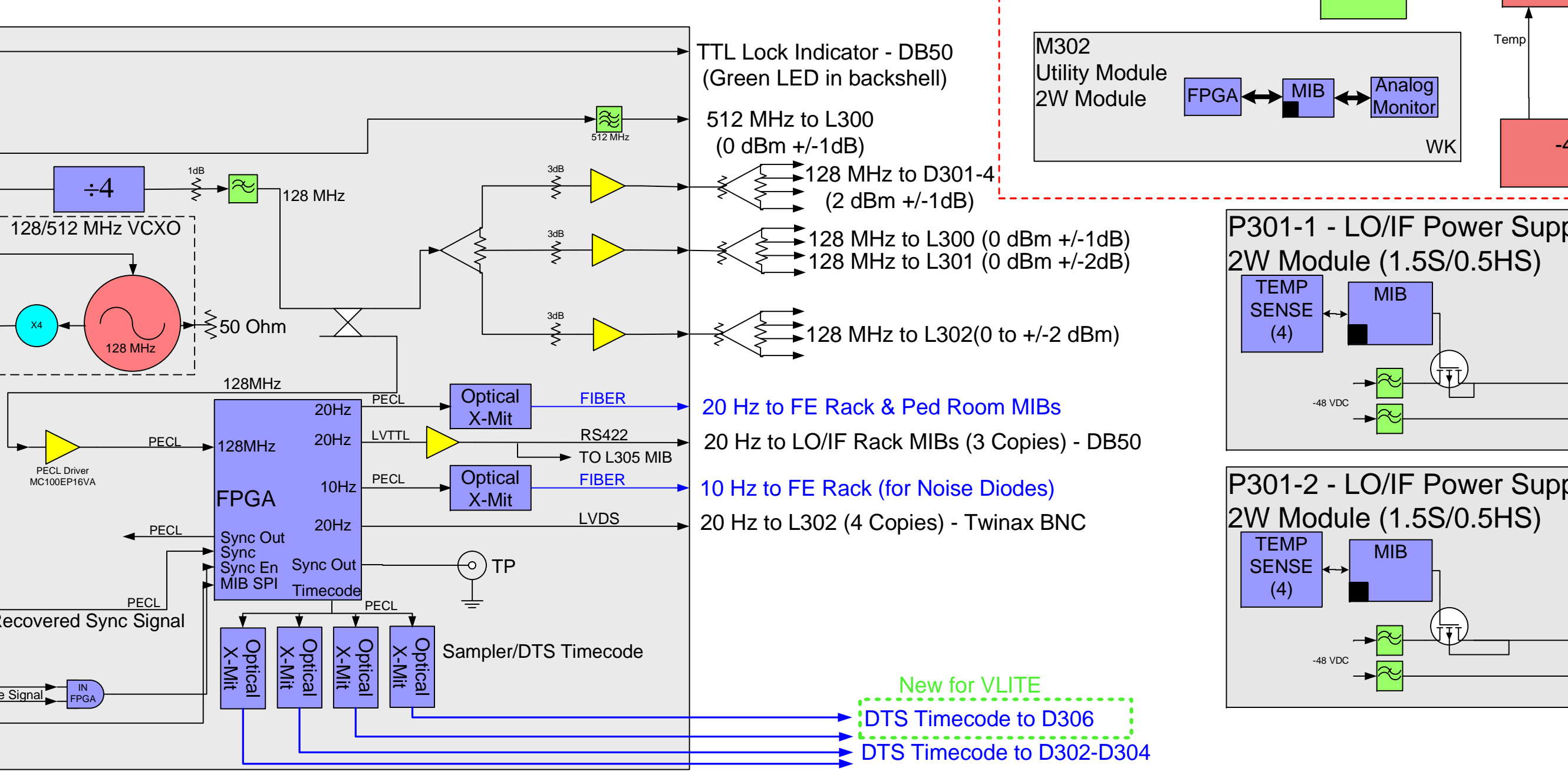
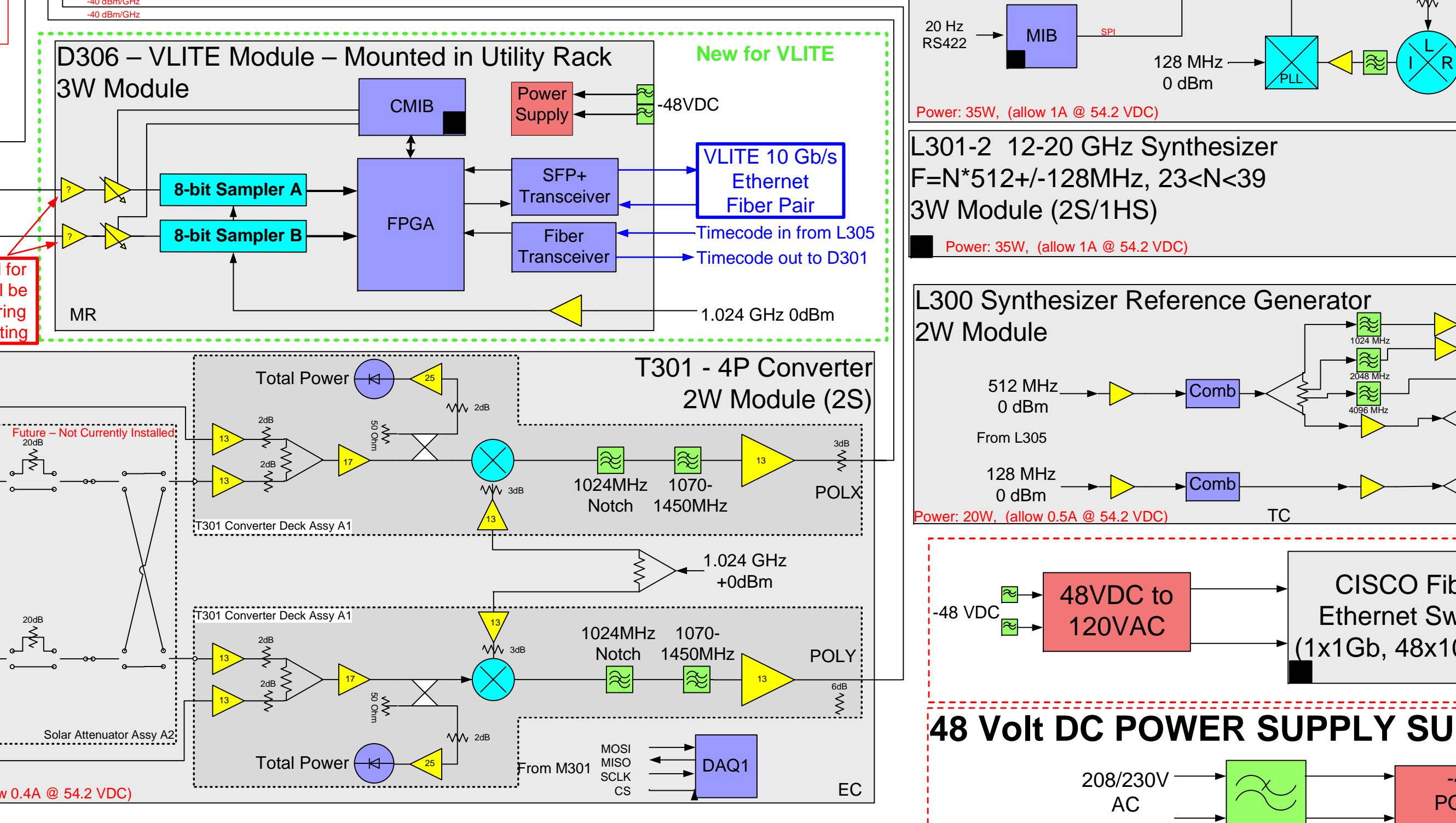
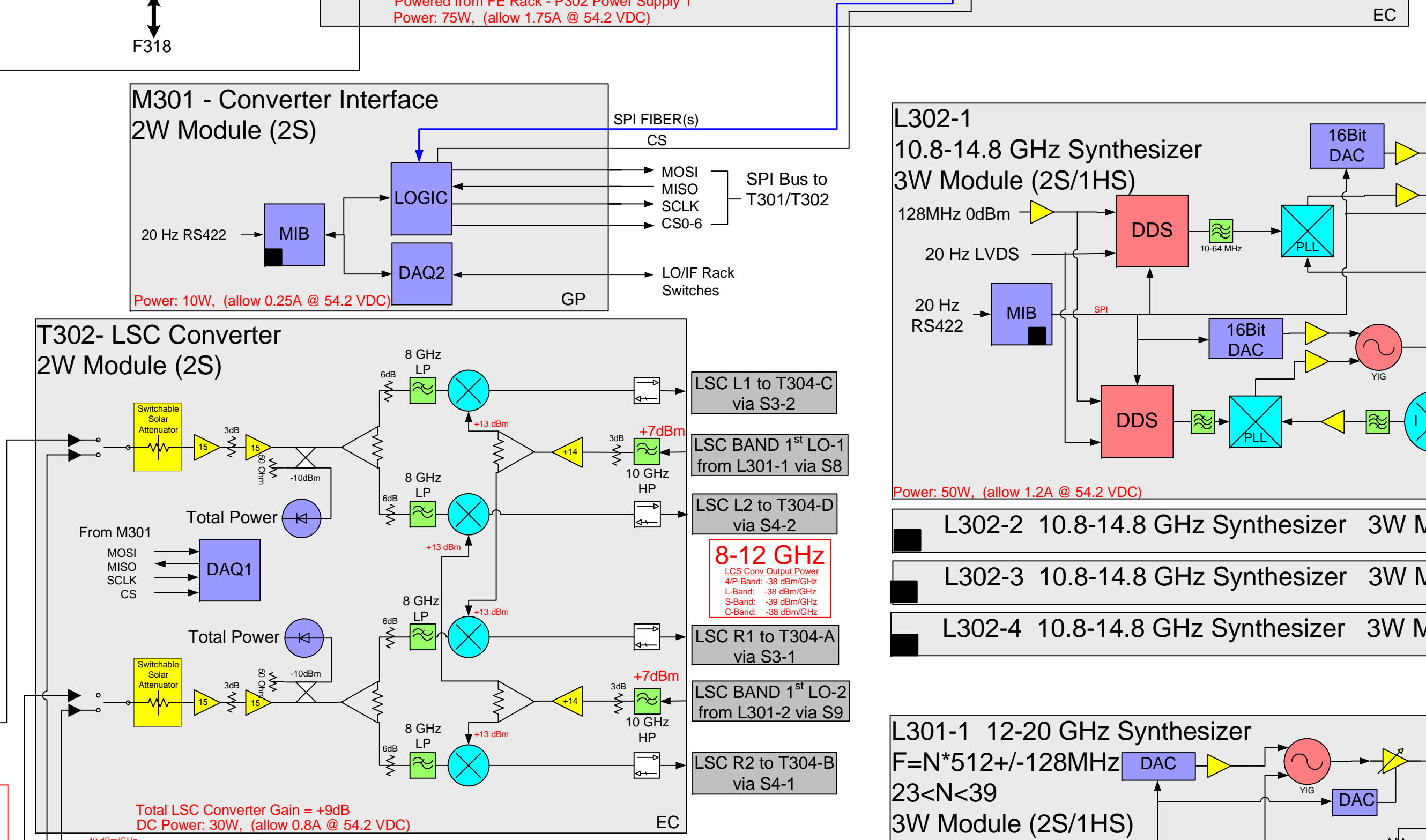
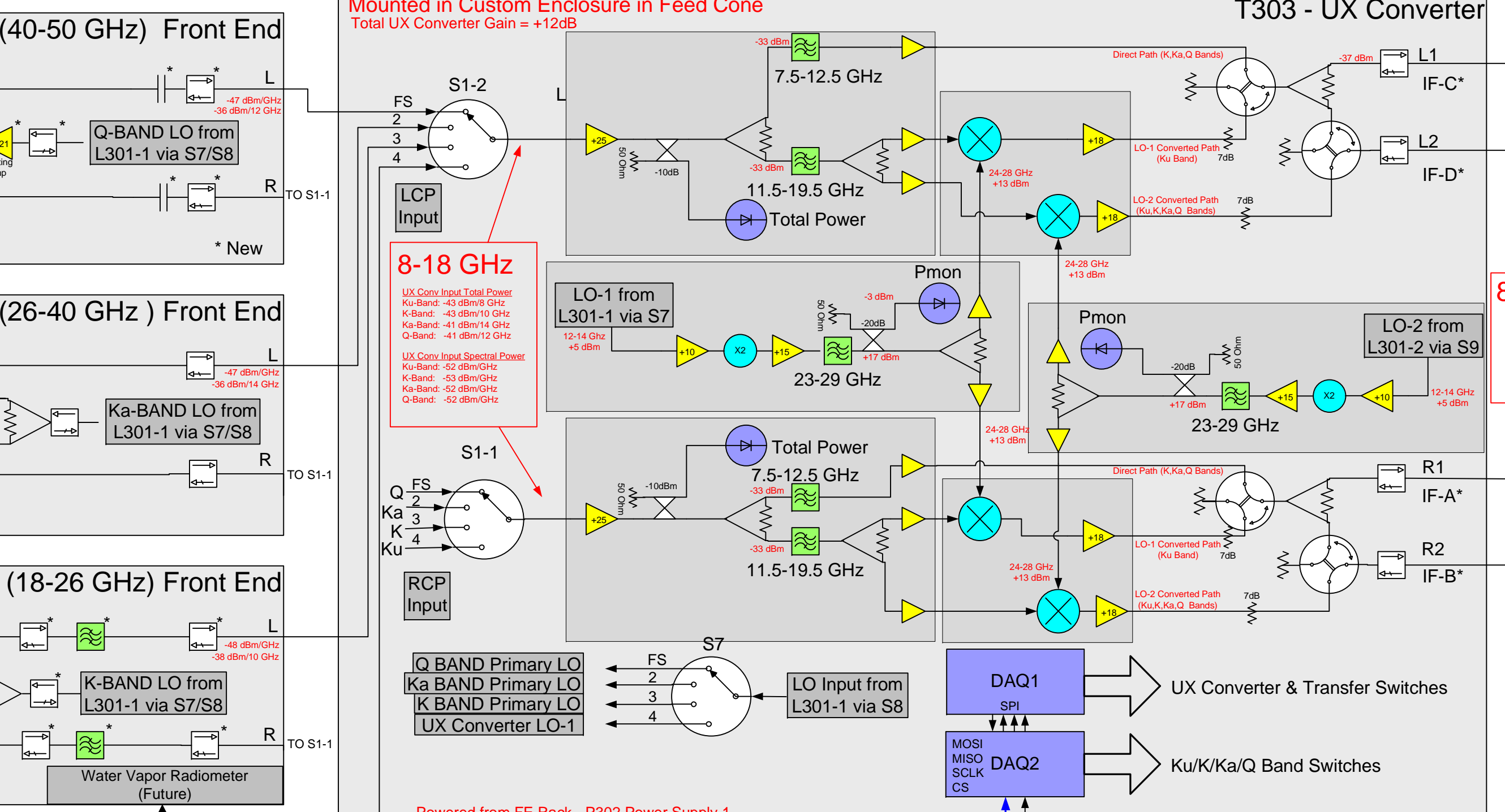
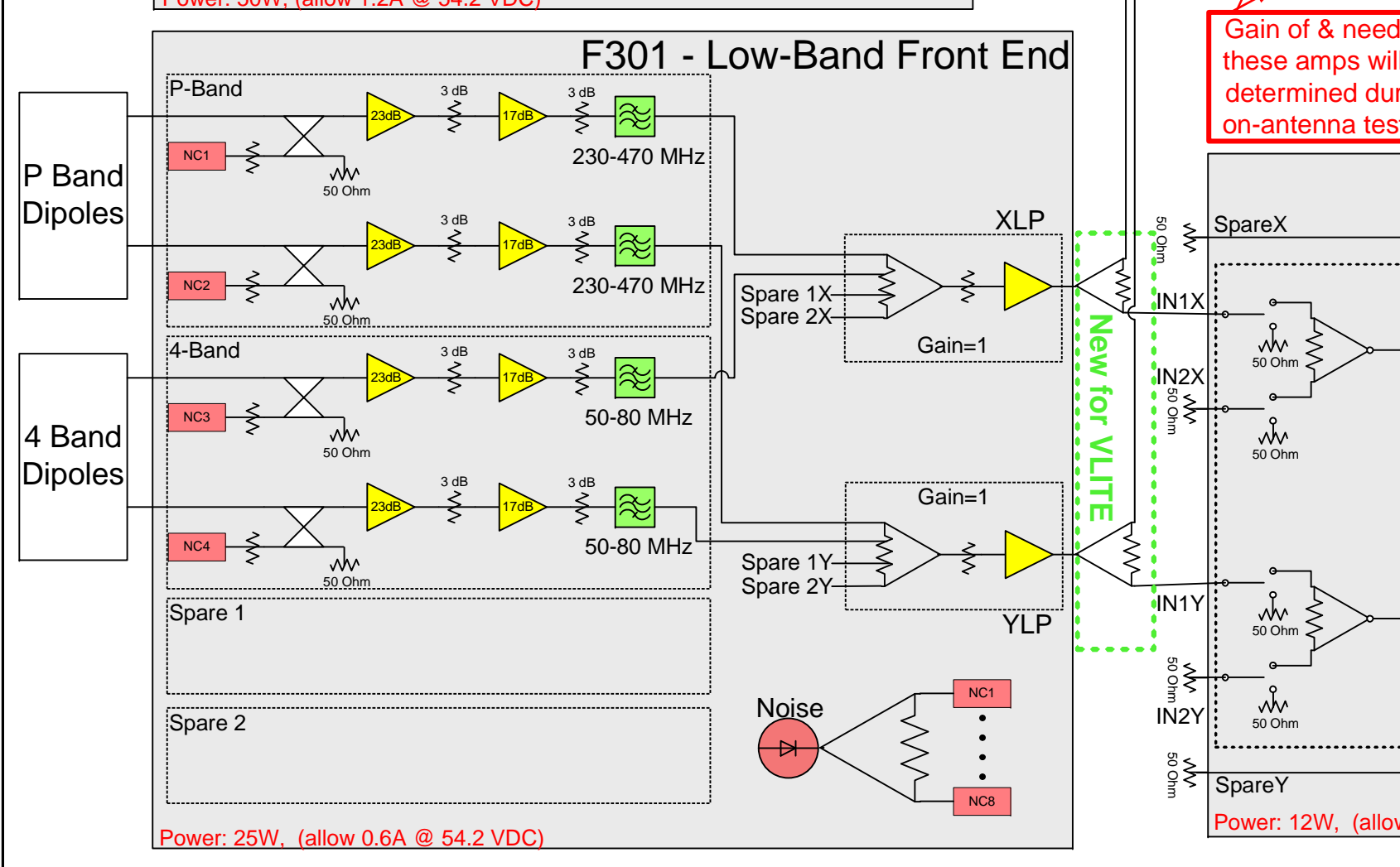
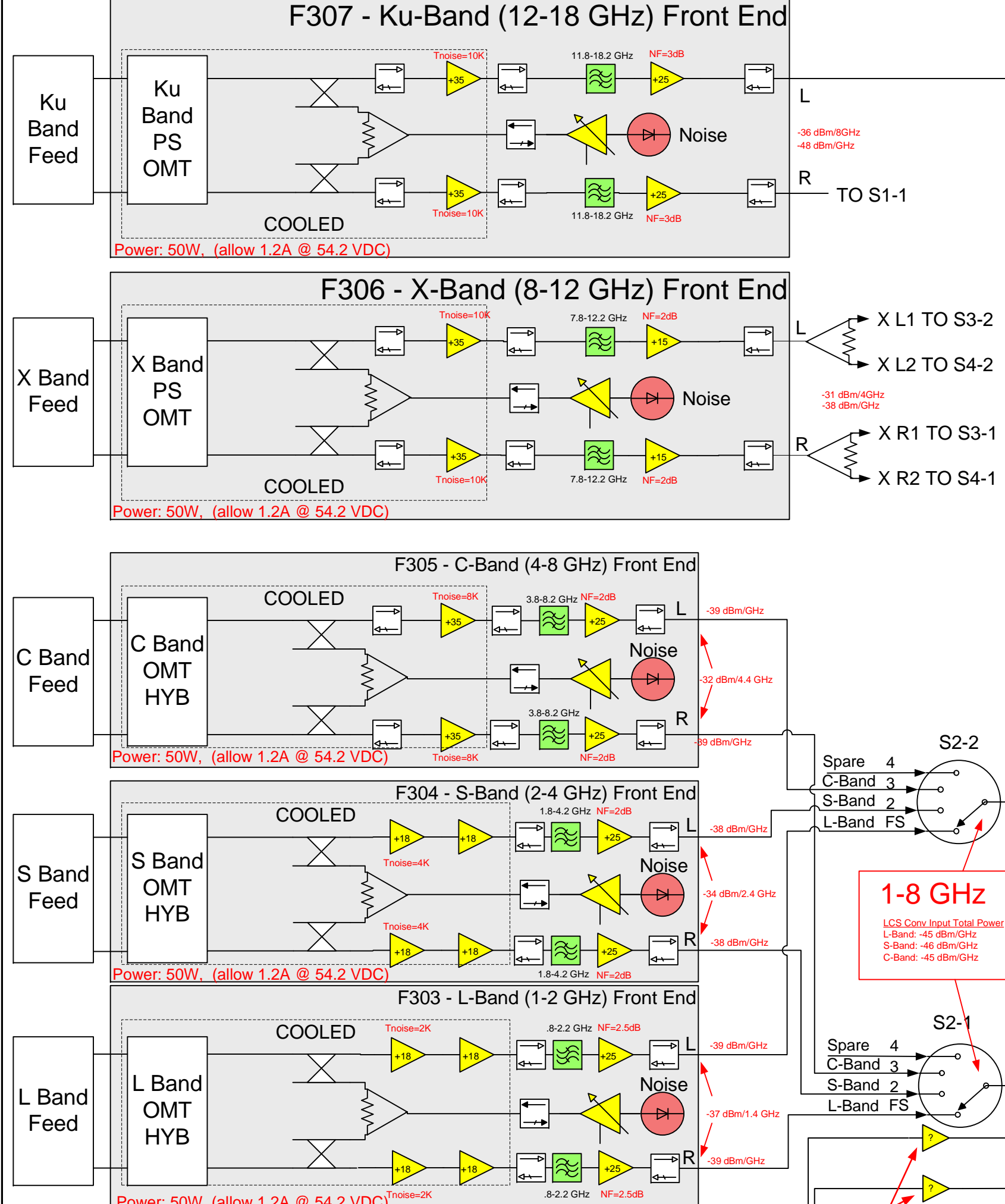
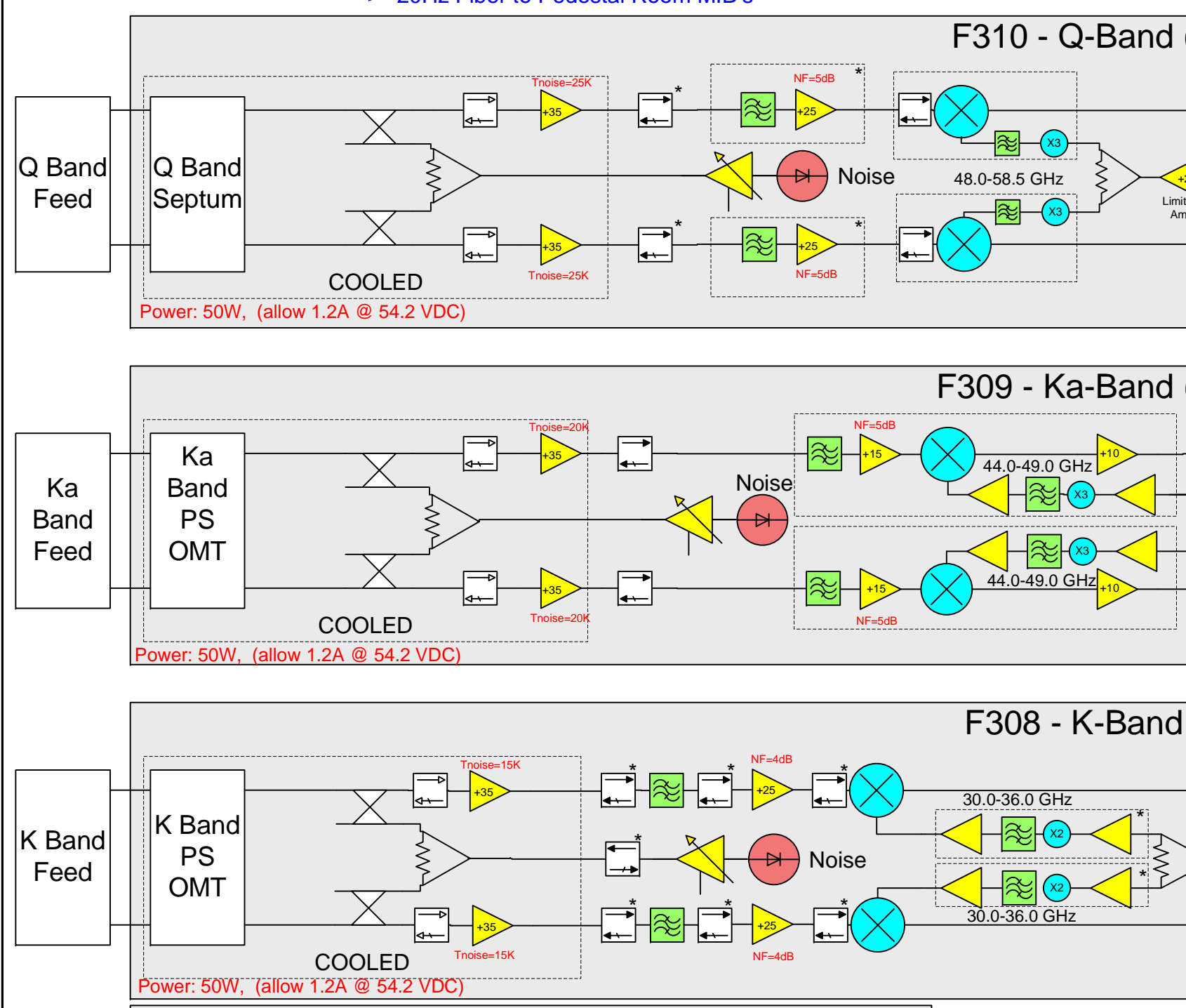
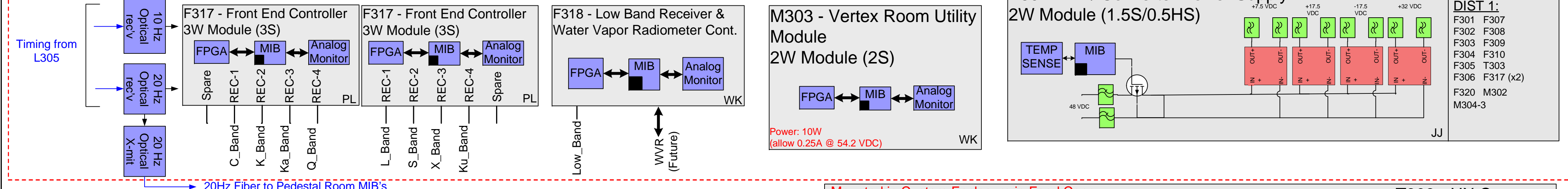

VLA Expansion Project  
Antenna Electronics  
Block Diagram (w/ VLITE)