

---

# LO Subsystem

Terry Cotter  
LO/IF Group Leader



# Introduction

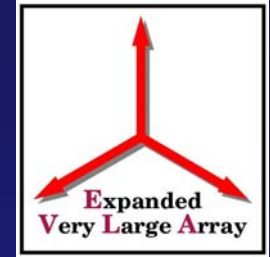

- The LO system
  - Overview
  - Module Specifications and Performance



# Master LO System

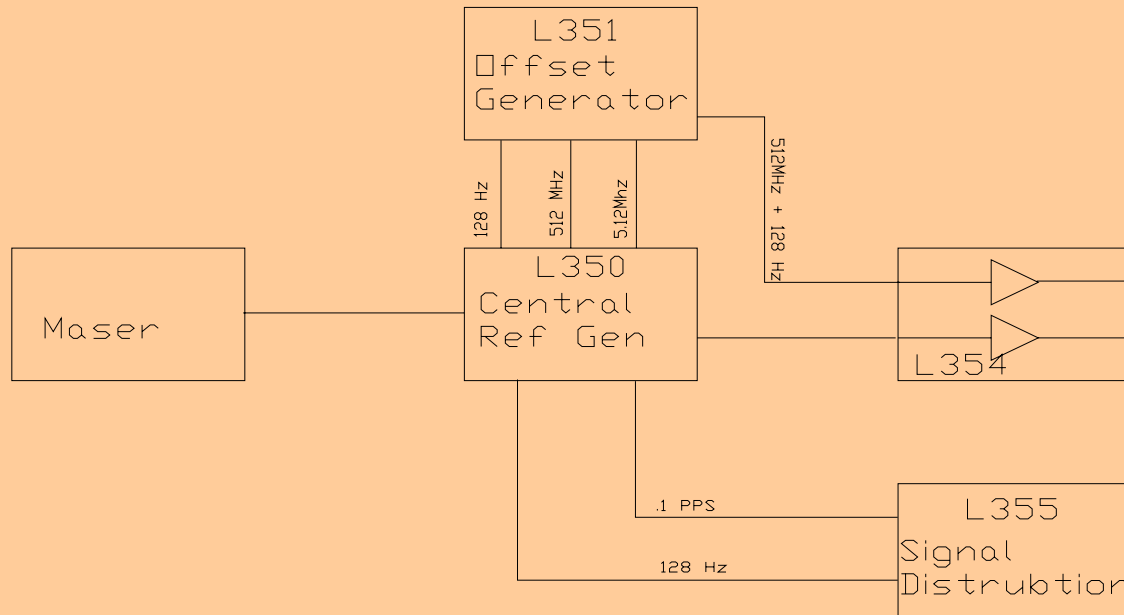
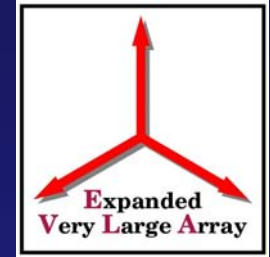



# Antenna Reference System

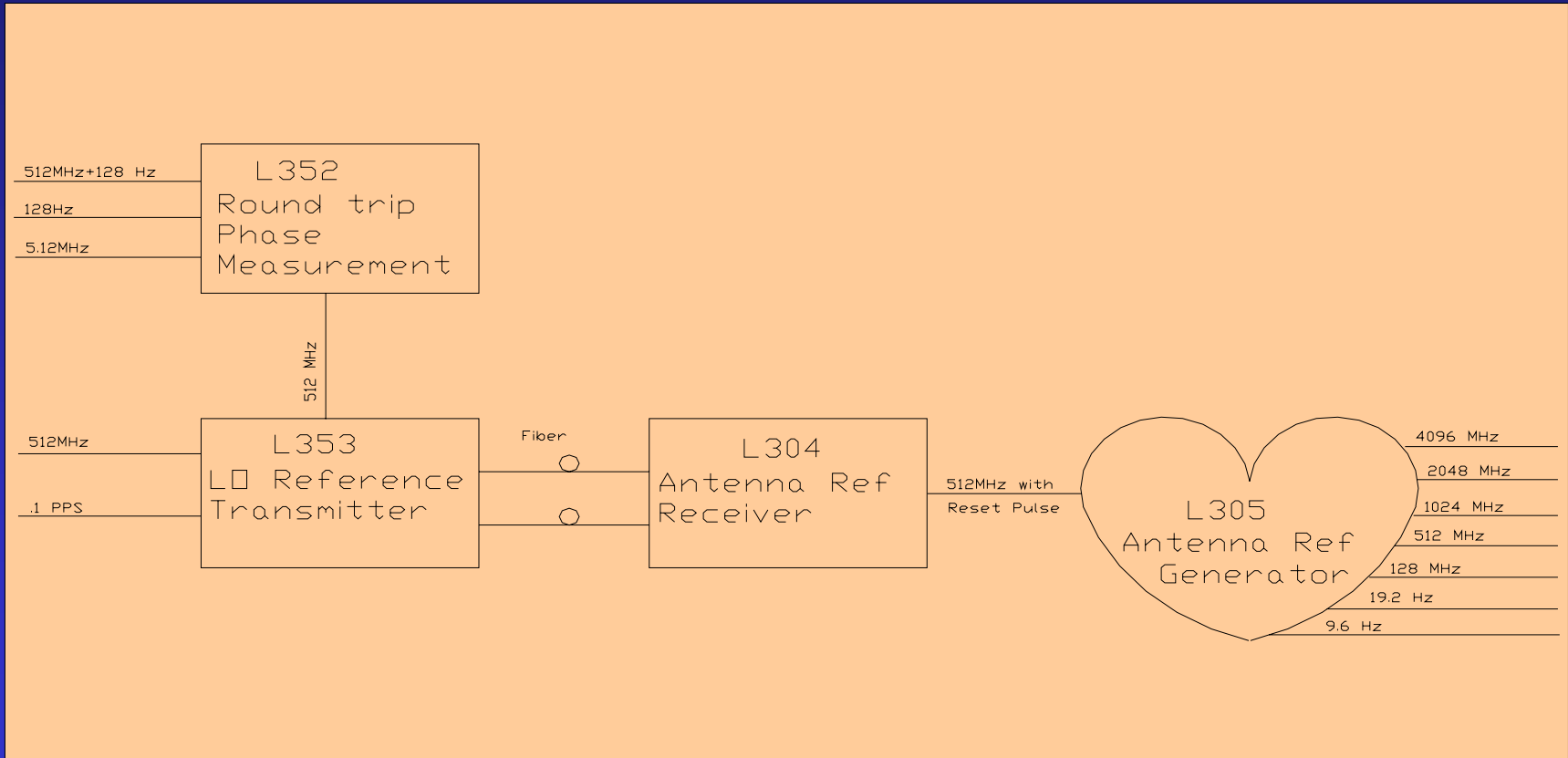
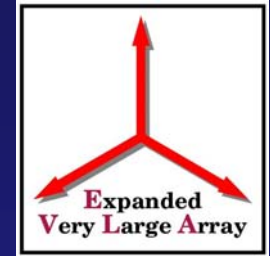



# L350 Central Reference Generator

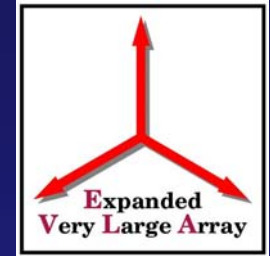

- Takes Maser 5MHz and generates the references required at the backend.
- Phase Noise of 512MHz dBc/Hz

	Specification	Measured
10 Hz	-74	-80
100 Hz	-104	-110
1K Hz	-134	-142
100KHz	-159	-162



# L350 Phase Noise

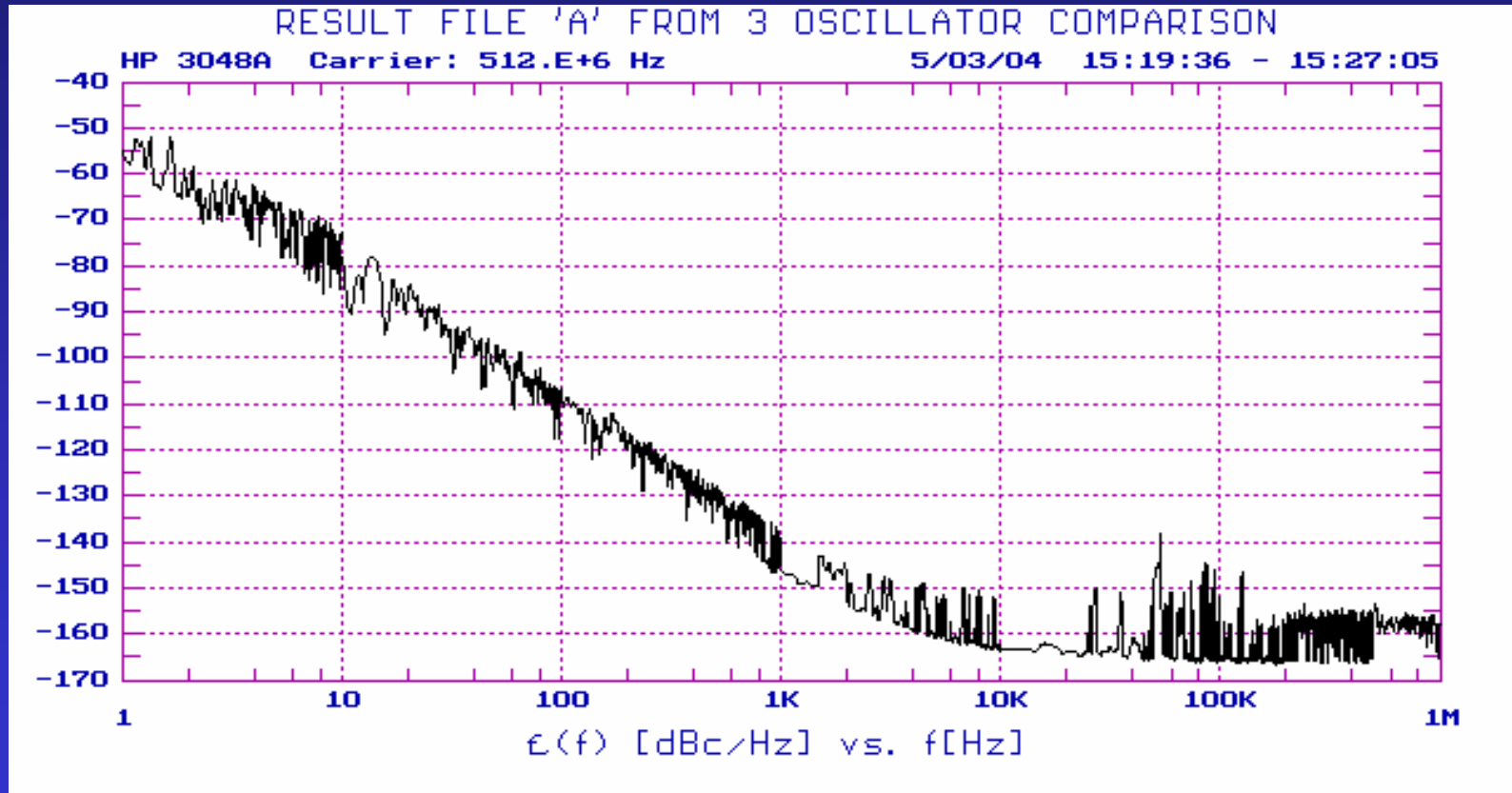
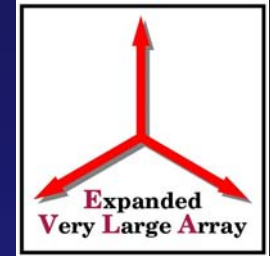



# L350 Performance

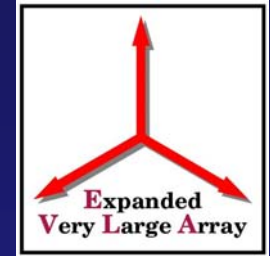

Frequency	Harmonics (Spec/Meas)	Spurs (Spec/Meas)
128 MHz	25 dBc / 41 dBc	40 dBc / 56 dBc
512 MHz	25 dBc / 54 dBc	40 dBc / 55 dBc



# L351 Offset Generator

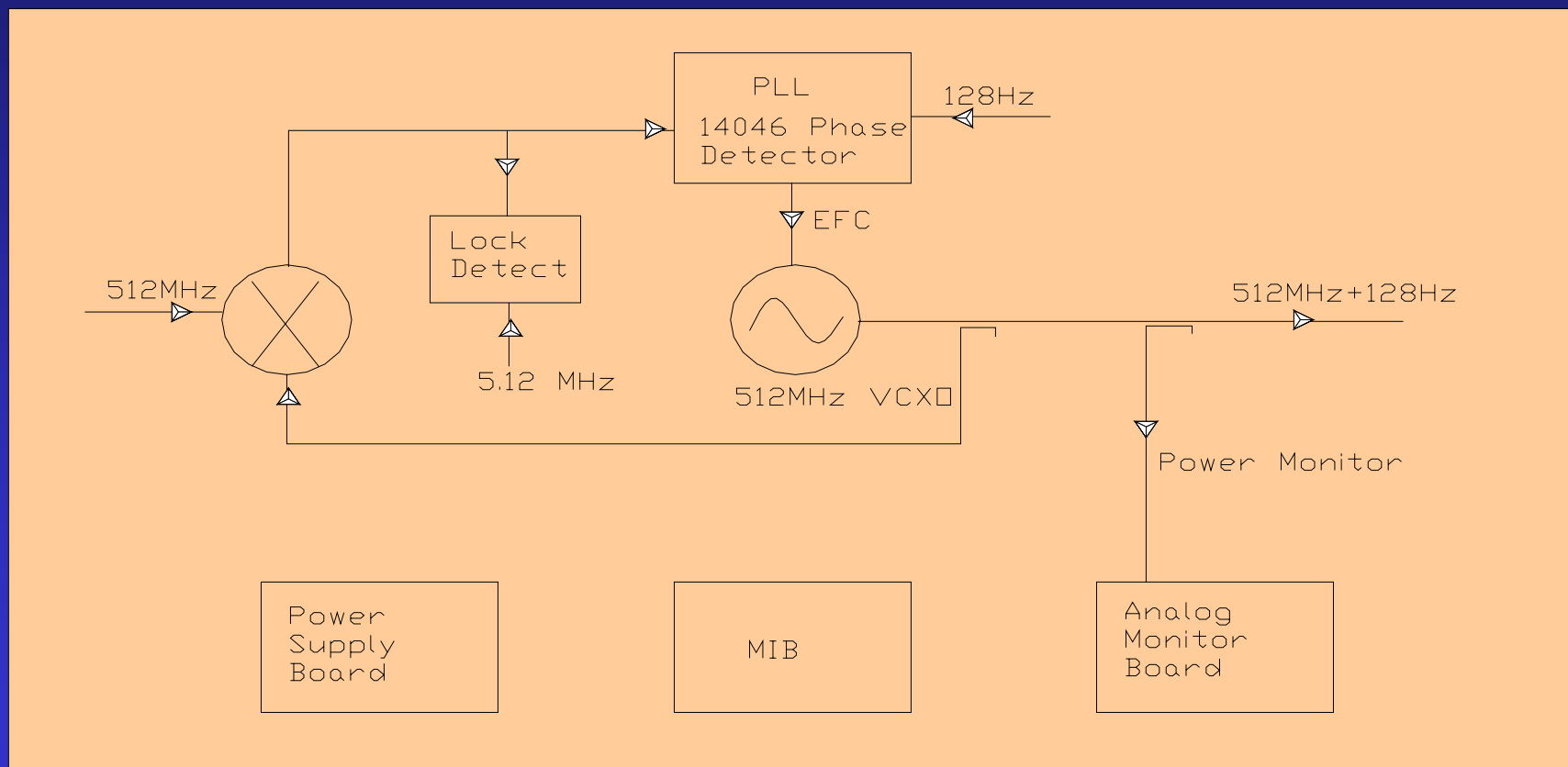
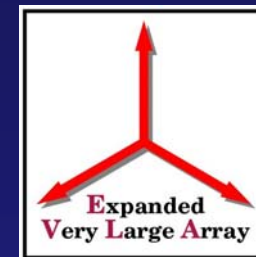





# L351 LO Offset Generator

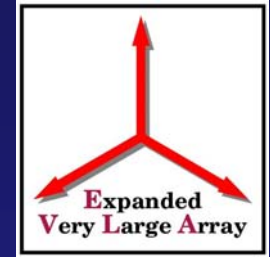

- Phase Noise required for Round Trip measurements
- Phase Noise measurements are still pending
- Total Phase Noise needs to be  $<500$  fs for times under 1 sec



# L352 Round Trip Measurement

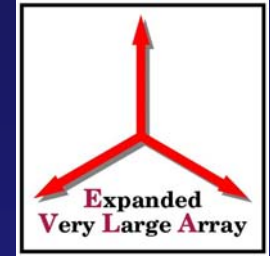

- To be Covered Later in another talk



# L353

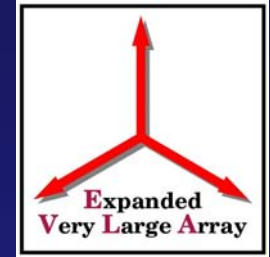

- L353 Functions Summary
- Hardware, Mechanical, and Software Status
- Testing



# L353 Functions

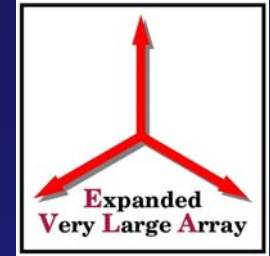

- Provides 512 MHz LO to Antenna via Fiber Optics
- On-Off Keying (OOK) used to sync 19.2 Hz Heartbeat
- Remote Monitor + Control Software
- Phase Noise Alarm and Returns 512 MHz for RTP



# L353 Block Diagram

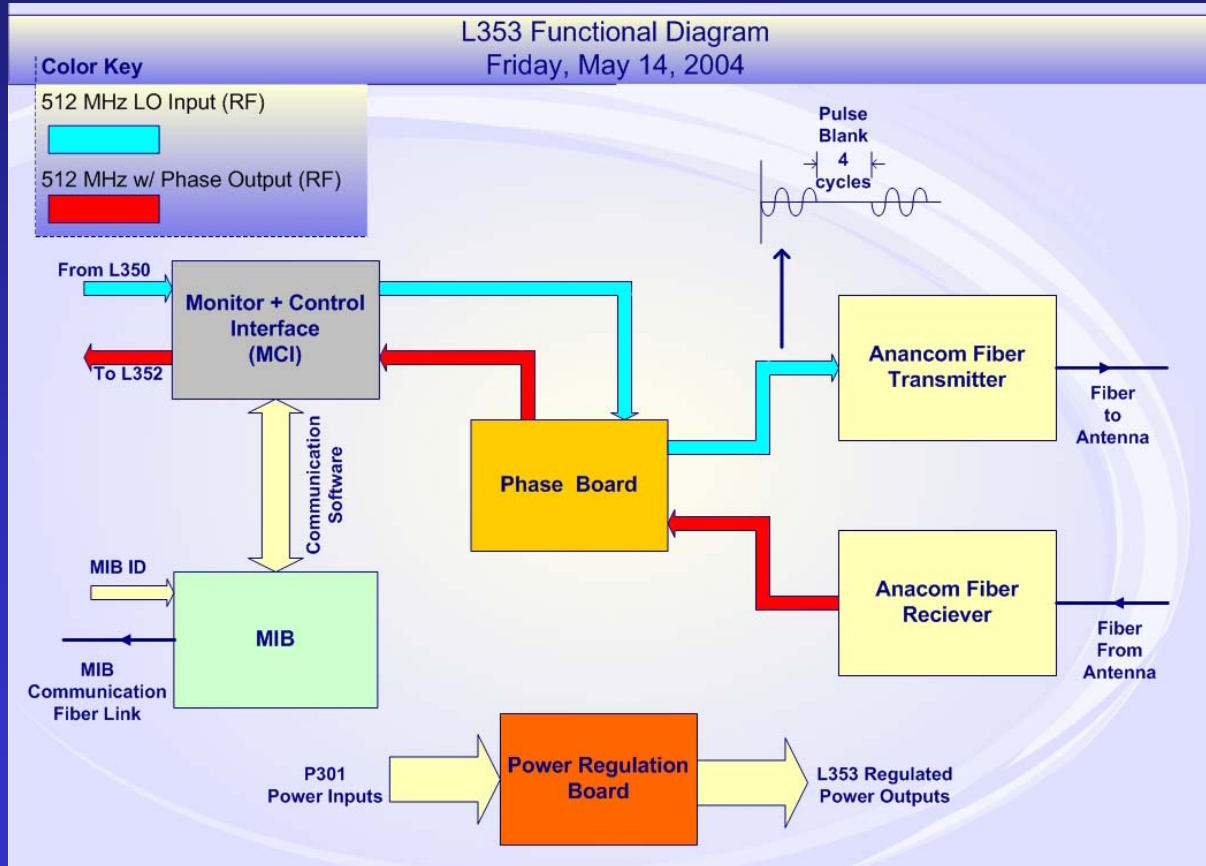
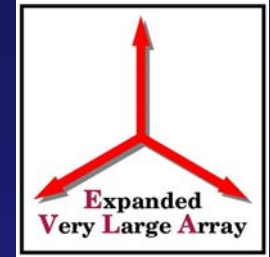



# Pulse Blanking

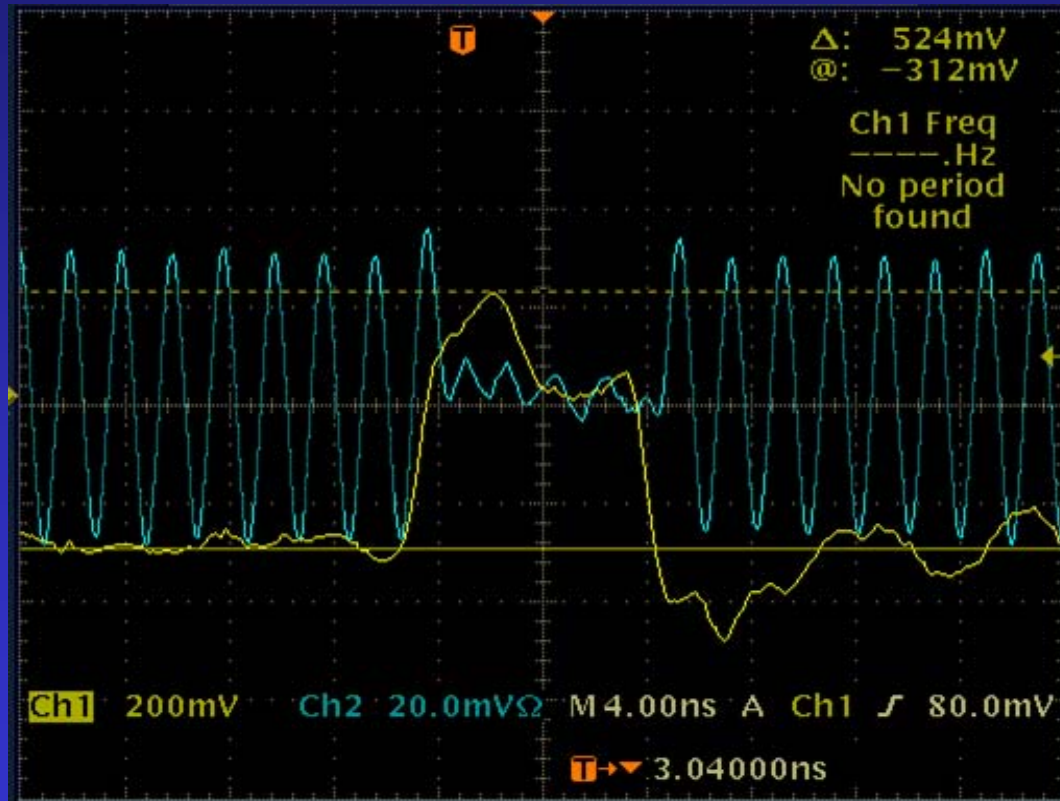
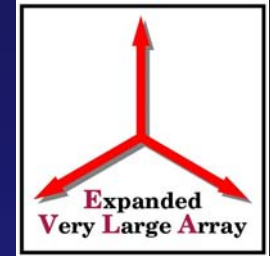



# Mechanical Drawings

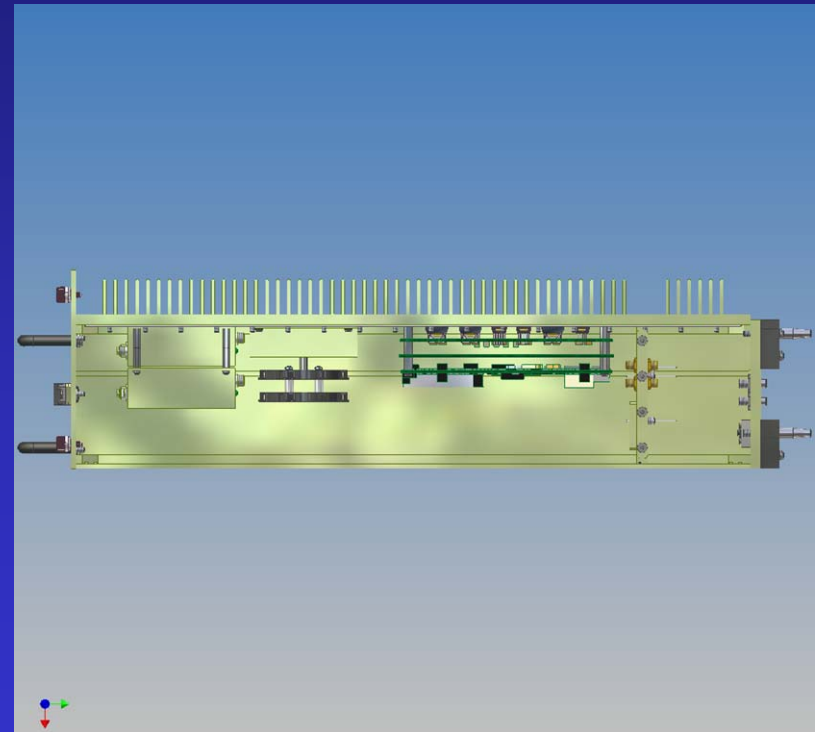
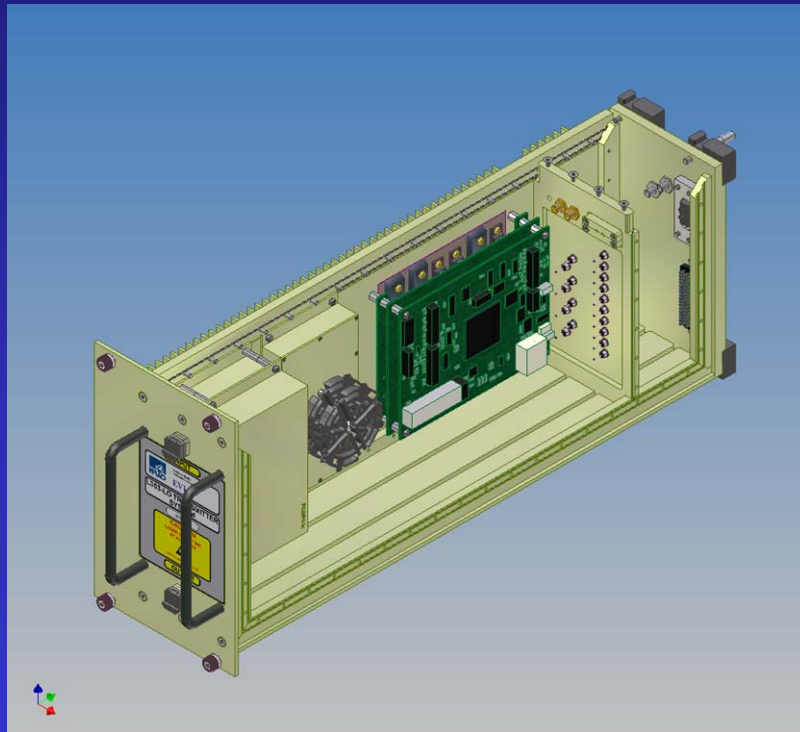
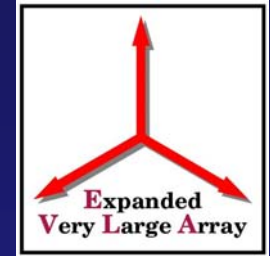



# L353 Summary

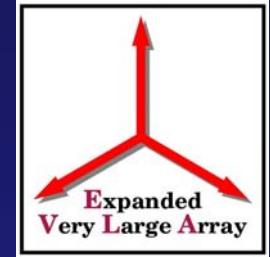

## Completed Work

- ☑ ICD
- ☑ Mechanical Drawings
- ☑ Part Lists
- ☑ Software/Firmware
- ☑ RF Shielding Tests

## Unfinished Work

- ☒ Last PCB Revisions
- ☒ Testing of new phase board





# L304 Antenna Reference Receiver

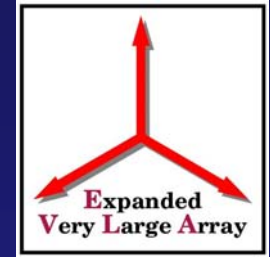

- Receives 512MHz reference with the .1pps reset pulse
- Returns 512MHz back to central antenna for roundtrip phase measurement
- Uses Anacom receiver



# L304 Reference Receiver

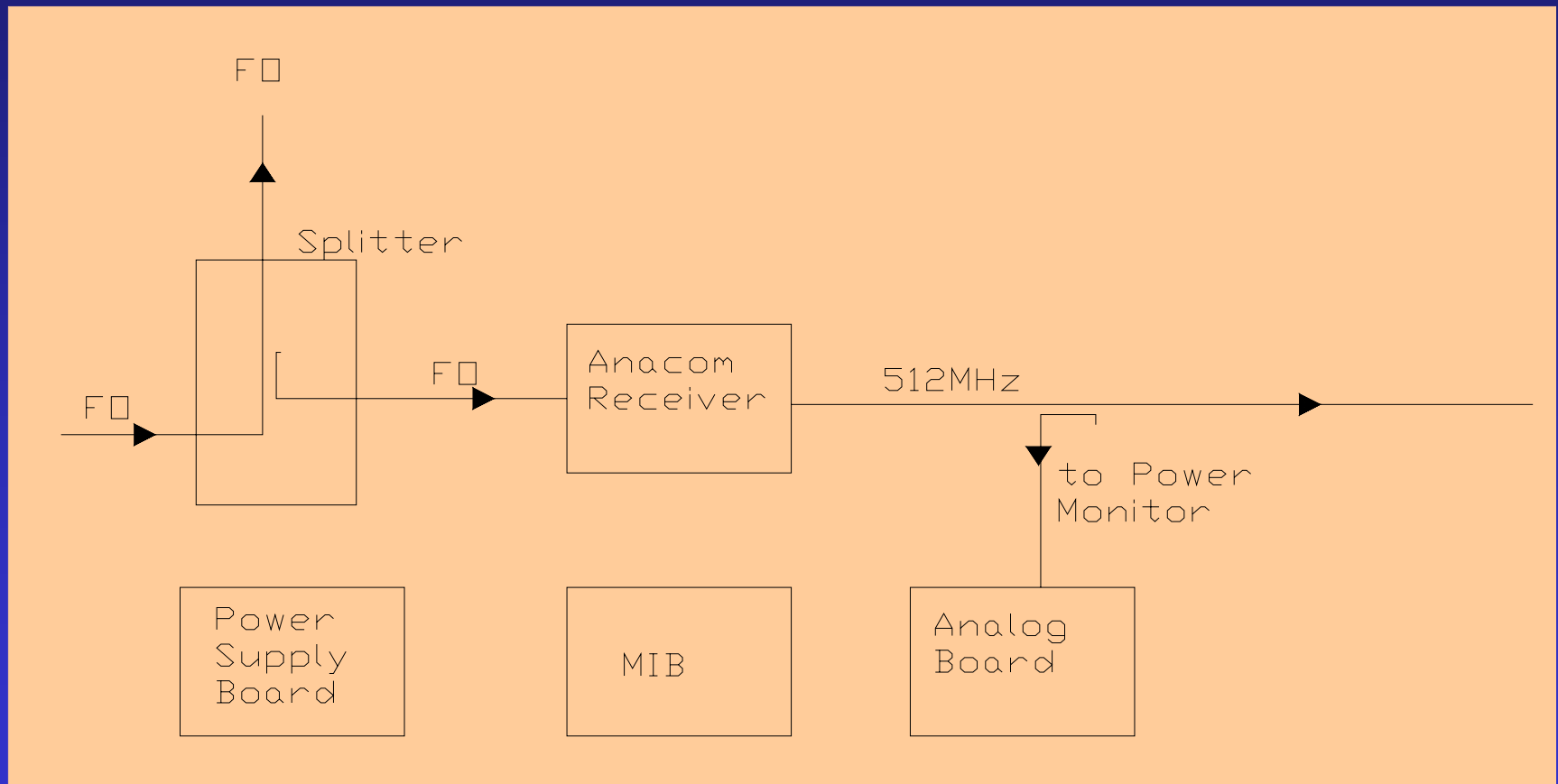
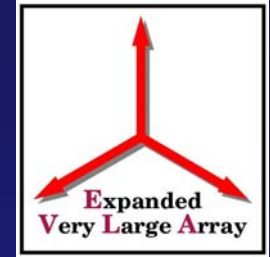



# L305 Antenna Ref Generator

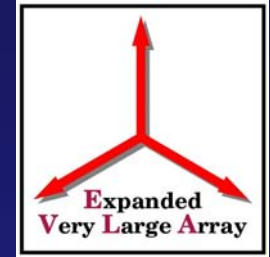

- Receives 512MHz plus reset pulse from L304
- Strips reset pulse off
- Cleans up 512MHz
- Generates references needed by antenna
- Synchronizes timing with reset pulse.

### L305 TIMING BOARD

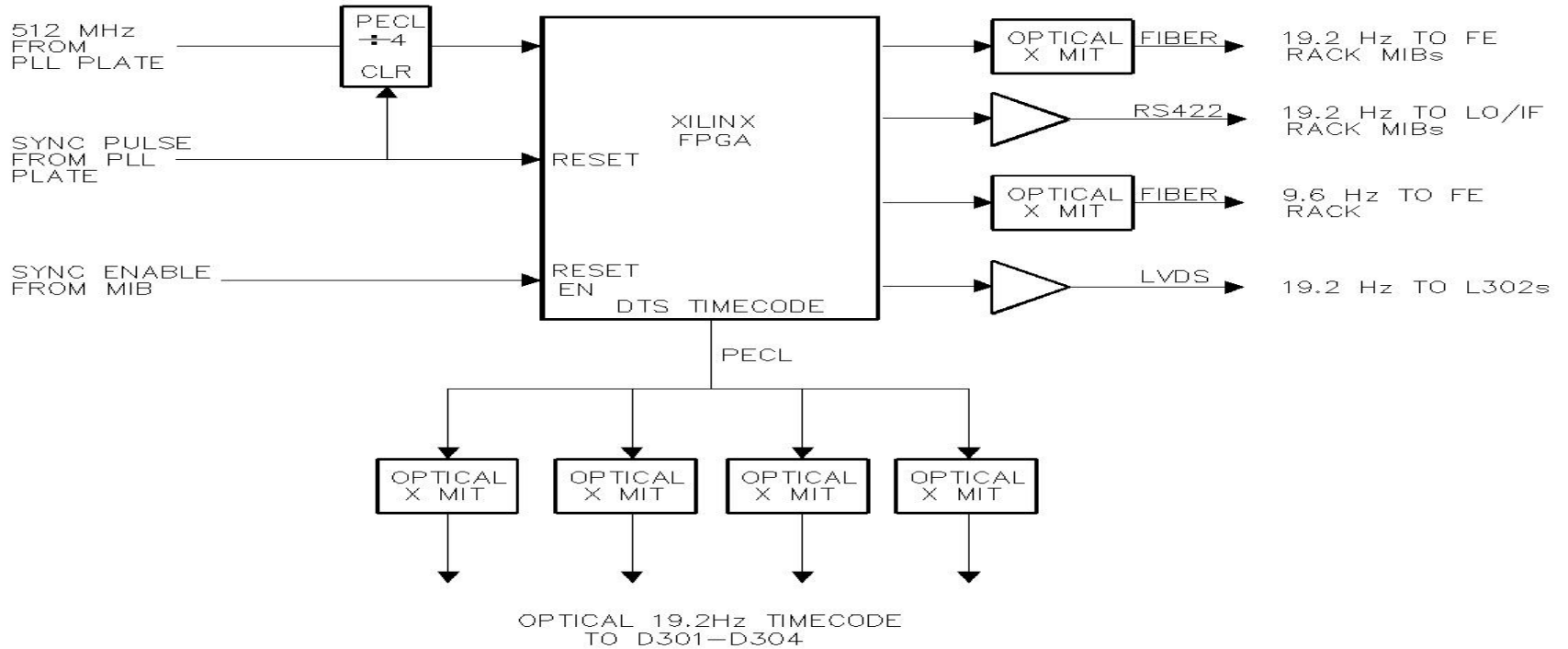

### L305 PLL PLATE

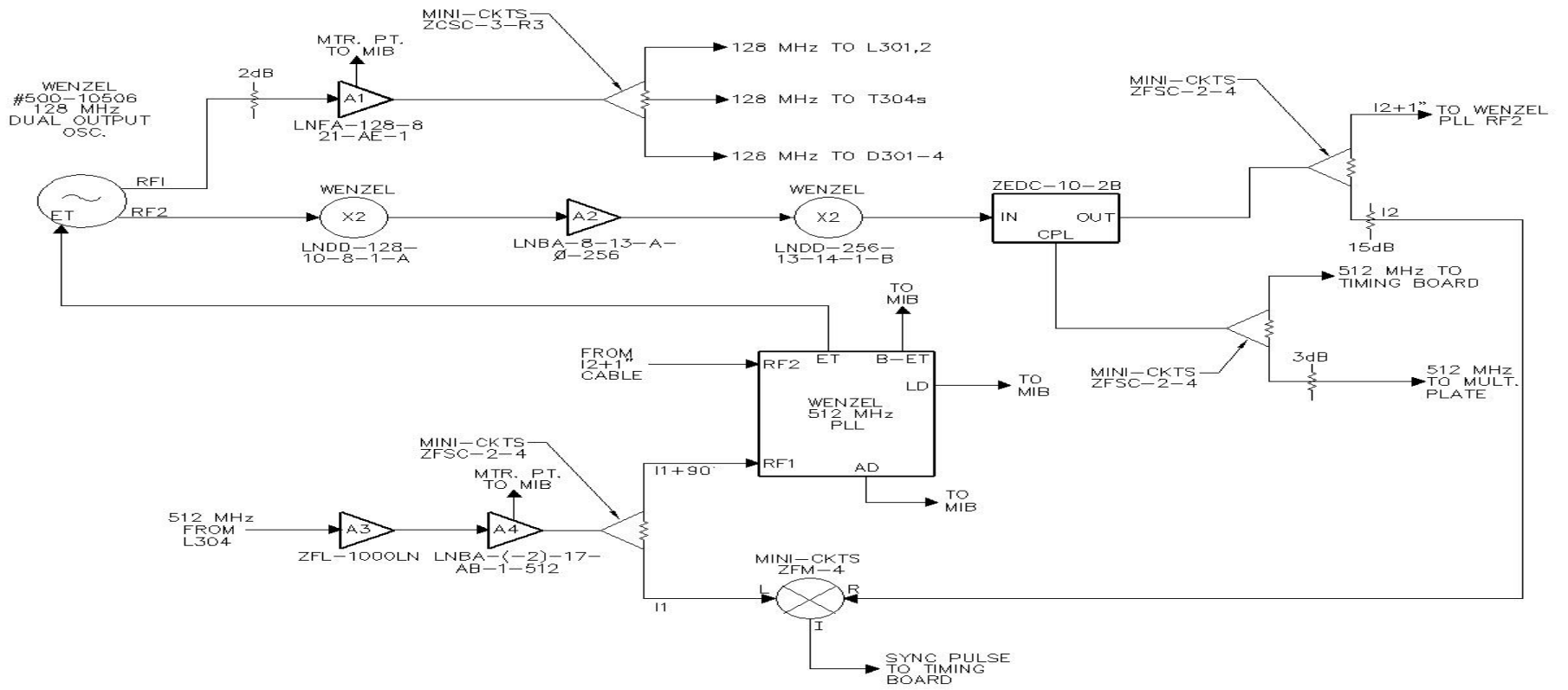

L305 MULTIPLIER PLATE

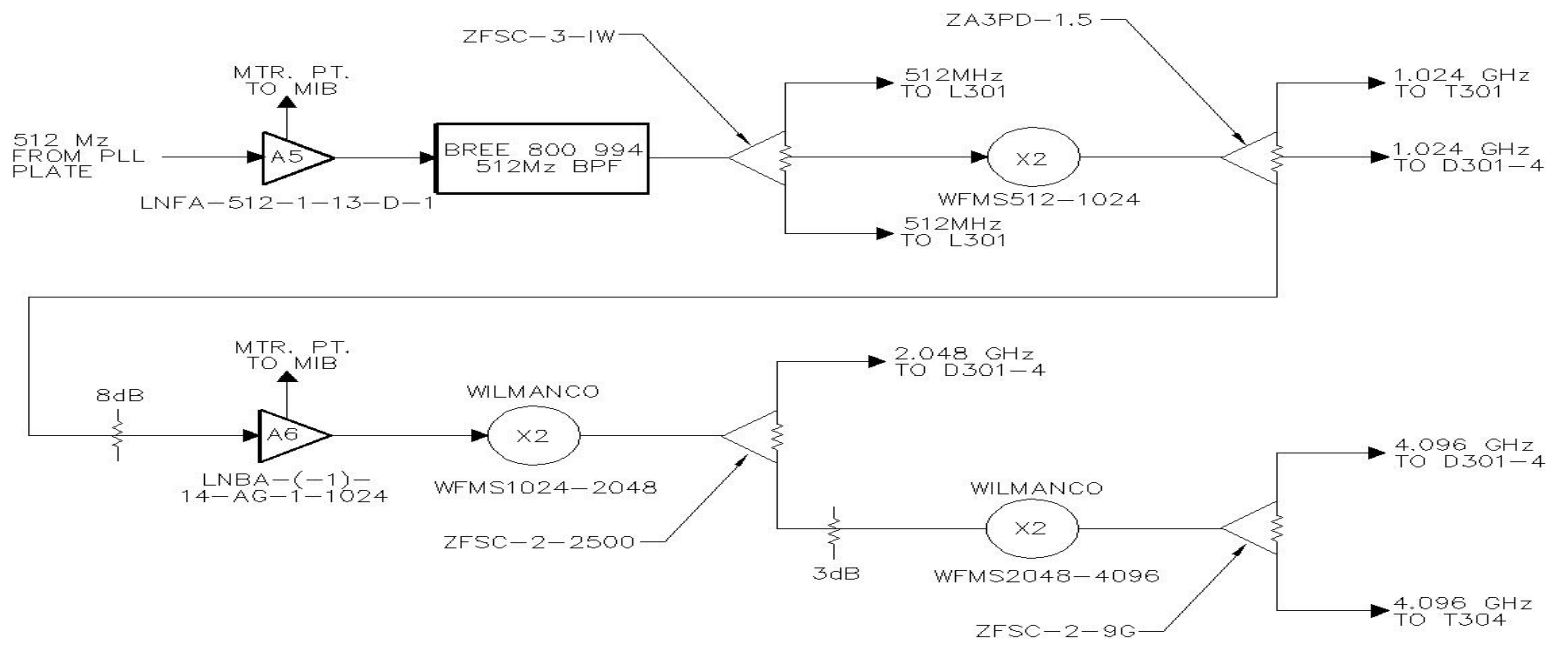



# L305 Harmonics

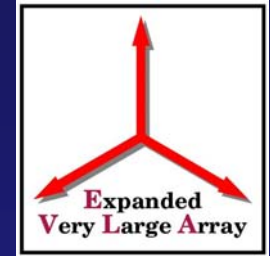

Frequency	Spec	Measured
128 MHz	25 dBc	None
512 MHz	25 dBc	42 dBc
1024 MHz	25 dBc	49 dBc
2048 MHz	25 dBc	34 dBc
4096 Mhz	25 dBc	None



# L305 Spurs

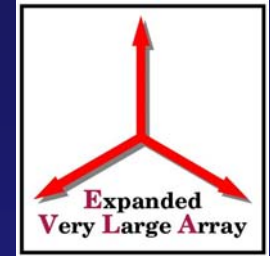

Frequency	Spec	Measured
128 MHz	40 dBc	> 47 dBc
512 MHz	40 dBc	> 59 dBc
1024 MHz	40 dBc	> 62 dBc
2048 MHz	40 dBc	> 55 dBc
4096 MHz	40 dBc	> 53 dBc





# L305 Antenna Reference Generator

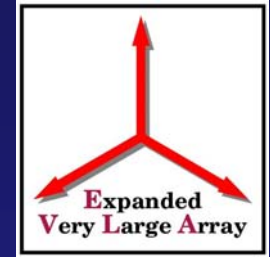

- Phase Noise of 512MHz dBc/Hz

	Specification	Measured
10 Hz	-74	-80
100 Hz	-101	-105
1K Hz	-129	-140
100KHz	-149	-142



# L305 Phase Noise

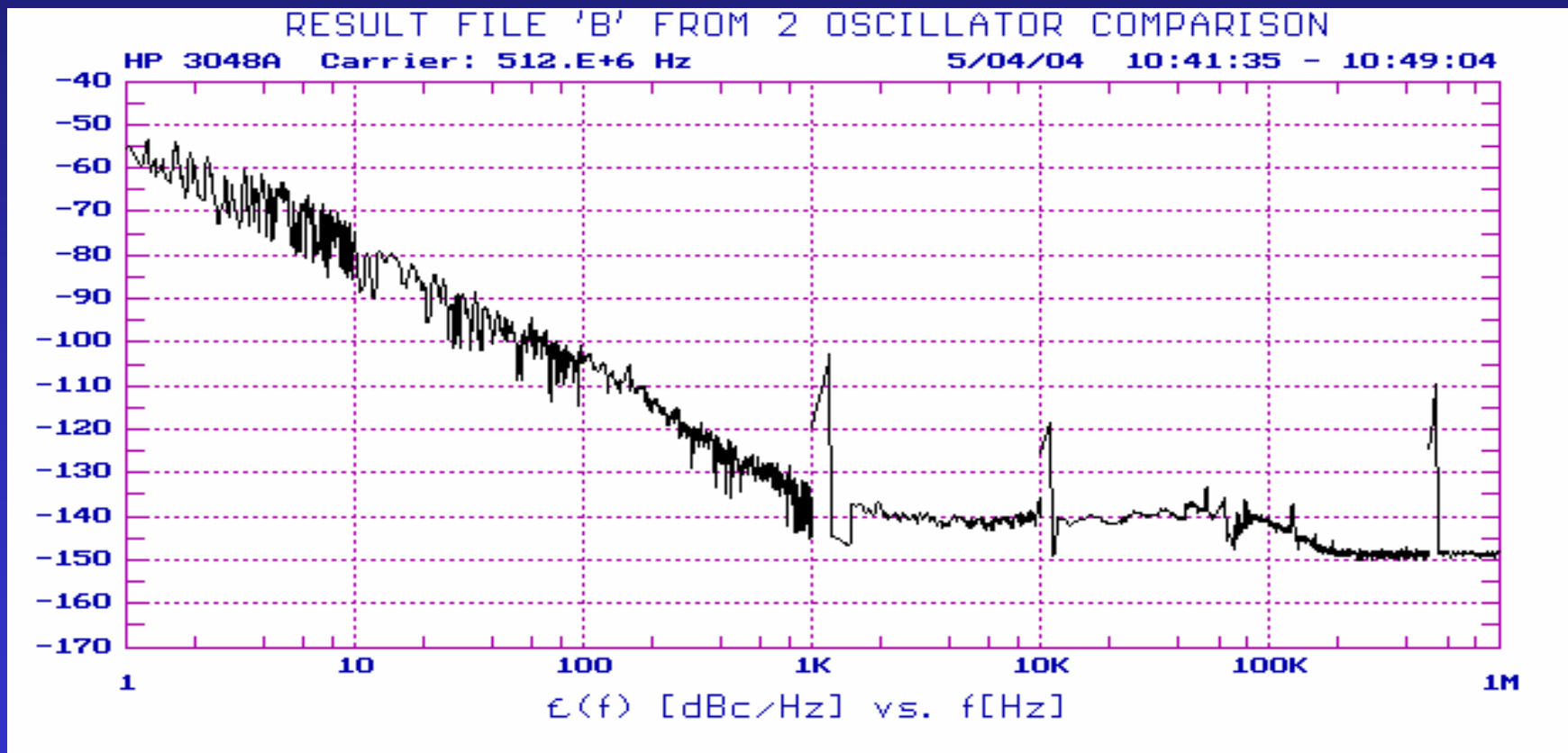
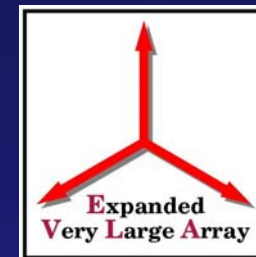



# Questions?

