

EVLA Feeds CDR

System Requirements

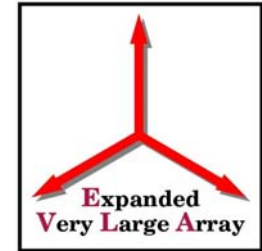

VLA versus EVLA



Band	Old VLA		New EVLA	
	Freq (GHz)	Feed Horn Type	Freq (GHz)	Feed Horn Type
L	1.35 - 1.75	Lens + Corrugated	1 - (1.2) - 2	Compact Corrugated
S	 	 	2 - 4	Compact Corrugated
C	4.5 - 5.0	Lens + Corrugated	4 - 8	Compact Corrugated
X	8.0 - 8.8	Linear Taper Corrug	8 - 12	Linear Taper Corrug
Ku	14.4 - 15.4	Pyramidal	12 - 18	Linear Taper Corrug
K	18 - 26.5	Linear Taper Corrug	18 - 26.5	Linear Taper Corrug
Ka	 	 	26.5 - 40	Linear Taper Corrug
Q	40 - 50	Linear Taper Corrug	40 - 50	Linear Taper Corrug



EVLA Feeds Rolled Out View

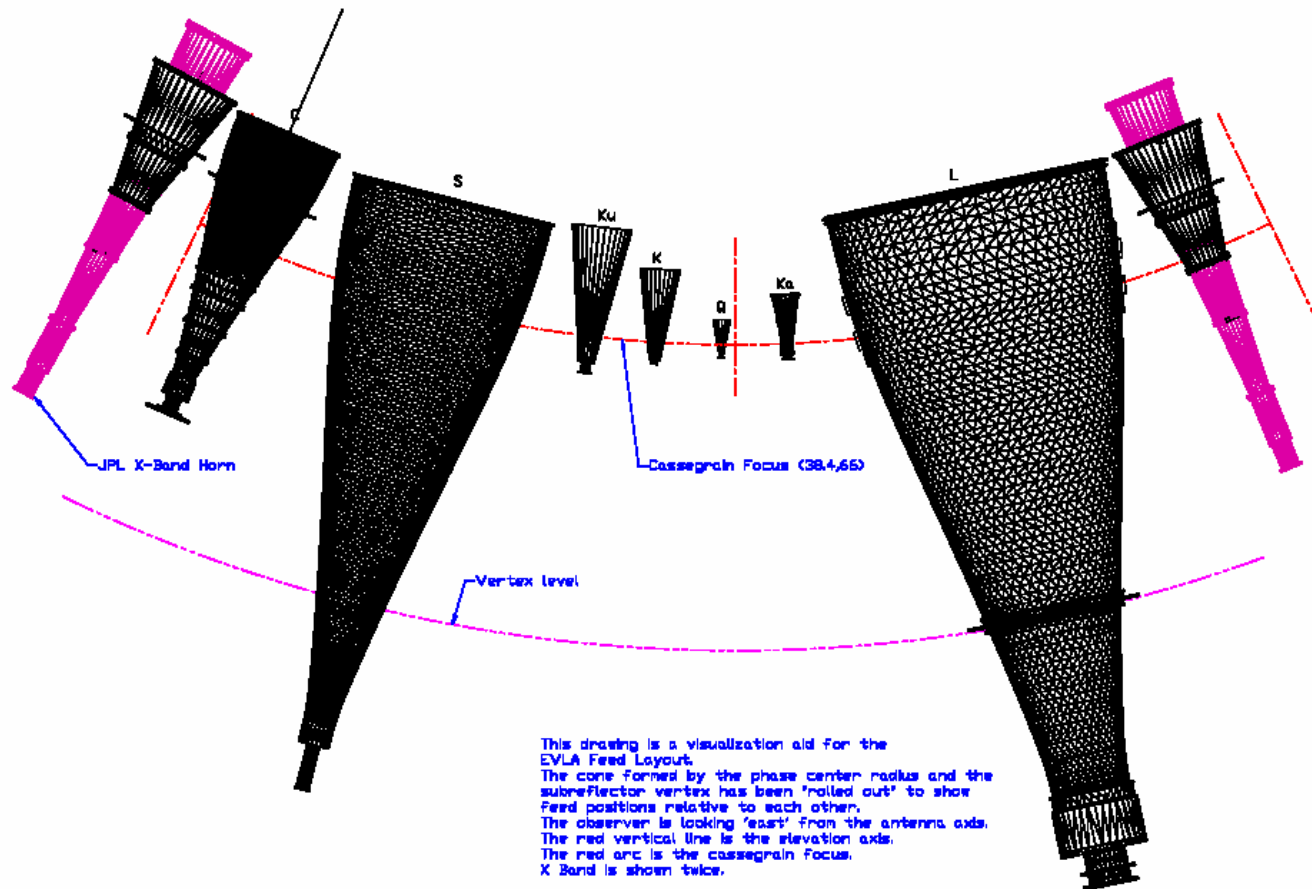
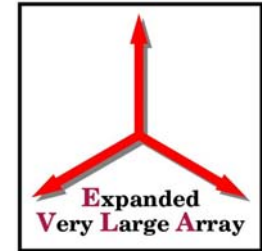



EVLA Ka-Band Rx Block Diagram

RHH : 6 Jan 2005

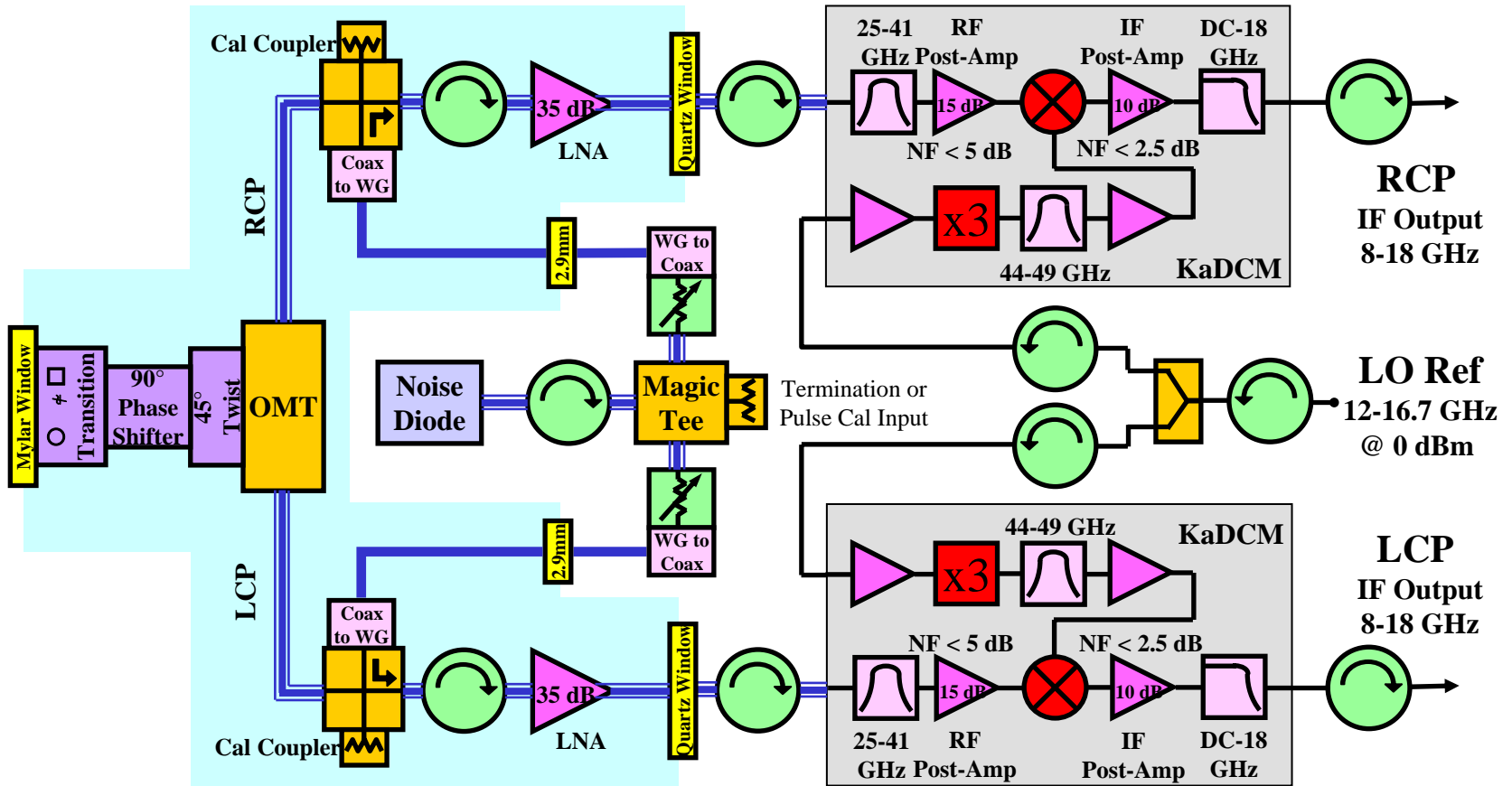
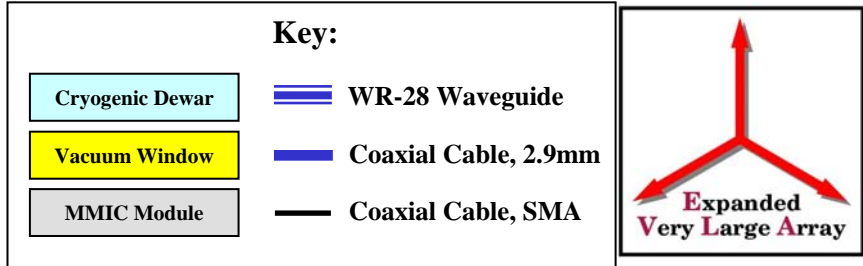



System Requirements

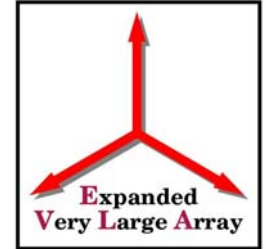

The following slides present the
Top Level
System Requirements
as specified in the EVLA Project Book

Note that many of these requirements pertain directly to the performance of the entire Telescope system. Consequently, the contribution from the Feeds may sometimes be very small compared to the dominating effects coming from the Antenna and/or Receivers.



EVLA On-Axis Efficiency

Includes the effects of aperture blockage, surface roughness, spillover, illumination, taper, feed alignment, diffraction losses, and VSWR losses for both the feed and LNA.

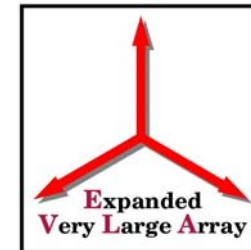

Band	Freq (GHz)	Required	Target
L	1.0 - 1.2	WWG [†]	WWG [†]
	1.2 - 2.0	0.45	0.50
S	2 - 4	0.62	0.68
C	4 - 8	0.60	0.66
X	8 - 12	0.56	0.61
Ku	12 - 18	0.54	0.59
K	18 - 26.5	0.51	0.56
Ka	26.5 - 40	0.39	0.43
Q	40 - 47	0.34	0.37
	47 - 50	TBD	TBD



EVLA Rx Band Noise Temperatures

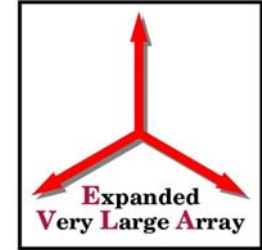

Band	$T_{\text{receiver}} (^{\circ}\text{K})^{\dagger}$	$T_{\text{Sky}} (^{\circ}\text{K})^{\ddagger}$	$T_{\text{System}} (^{\circ}\text{K})$
L	14	12	26
S	14	12	26
C	16	10	26
X	20	10	30
Ku	25	12	37
K	34	25	59
Ka	40	13	53
Q	42	26 - 68	68 - 110

\dagger Receiver temperature averaged across full band.

\ddagger Antenna, CBG & atmospheric contribution to T_{Sys} when pointed at zenith in dry winter weather.



Antenna Primary Beam Power Pattern Similarity



- **Required:** The normalized primary power pattern of any antenna must not vary by more than 0.03 (in power units) from the average of all antennas, within the 3 dB FWHP ellipse.
 - **Example:** At the 3 dB angle defined by the mean power pattern, all antennas must have a power gain between 0.47 and 0.53 of the peak forward gain.
- **Note:** This is also affected by the overall antenna structure. For the feeds themselves, it means holding the machining tolerances to better than 3%.
 - Most machining tolerances are better than 0.01”.



Antenna Primary Beam Differential Phase



-
- **Required:** The differential voltage phase within the 3 dB ellipse may not vary by more than 0.35 degrees with respect to the on-axis value.
 - **Note:** As this is an antenna performance specification, it can only be measured using the standard VLA holography technique.
 - *This has yet to be carried out on any EVLA antenna.*



Feed Illumination



- **Required:** The illumination centroid is to be within 5 cm of the antenna center.
- **Note:** This refers to the illumination of the primary surface after going through the entire optics path. All antennas should be identical to within 5 cm. With respect to the feeds, it is largely an alignment issue.



Beam Squint Stability



- **Required:** The angular separation between the RCP and LCP beams must remain constant to less than 6 arc seconds over a period of 8 hours.
 - **Note:** This is largely a feed alignment and feed stability issue. The “squint” arises from the feeds being located along the feed circle which is offset from true optical axis.
- Holography and astronomical measurements will be required to finalize the proper feed positions.



Stability of Cross-Polarization



-
- **Required:** Over an 8 hour period, and under stable weather, the RCP and LCP polarization ellipses within the inner 3 dB of the antenna primary beam (FWHP) shall be stable to:
 - 0.002 in Axial Ratio
 - 2 degrees in Position Angle
 - **Note:** This is a mechanical stability issue, not only for the feeds but for the entire antenna structure. This spec only applies for $l > 6$ cm where the gravitational deformation of the surface and sag of the feed legs does not influence the polarization.
 - **Also:** In practice, the polarization will undoubtedly be dominated by mismatches arising between the polarizer & the LNA's or between other components in the signal path.
-



Ellipticity



-
- **Required:** The RCP and LCP on-axis polarization ellipse (voltage) axial ratios are to be between 0.9 & 1.0 (or 0.92 dB)
 - **Required:** The axial ratios of the polarization ellipses are to be the same for all antennas at a given frequency, to within the same tolerances as given above.
 - **Desired:** The on-axis LCP & RCP major axes are to be orthogonal to within 10° .
 - **Note:** This is primarily a polarizer spec, however a feed with a poor on-axis cross-polarization term could be a problem.
 - A 16 dB cross-pol results in a 1 dB axial ratio or 5% D-Term.

So feeds having a cross-pol better than 30 dB are desirable.



Overview of Feed CDR Presentations



-
- | | |
|------------------|---|
| Srikanth | - Completed Feed Designs (L, C, & Ka) |
| Srikanth | - Feeds Under Design (S, X & Ku) |
| Rick Perley | - EVLA Antenna Test Results |
| Jim Ruff | - Feed Cone Design |
| Hollis Dinwiddie | - Existing High Frequency Feeds (K & Q) |
| Hollis Dinwiddie | - Fabrication of Laminated Feeds (L & S) |
| Jim Ruff | - Fabrication of Machined Feeds (C, X, Ku & Ka) |
| Dan Mertely | - RFI Issues |
| Troy Jensen | - Feed Testing Plans |
| Bob Hayward | - Project Schedule & Budget |
-