

## 4 Antennas and Feeds

Jim Ruff, S. Srikanth  
Last changed 2006-Apr-04

### **Revision History:**

#### **2002-Feb-28, Rev C**

Add paragraph on RFI; identify cable, tubing, and ducting routing in the vertex room as a system-engineering task; add paragraph on AC power budget and clean vs. dirty power; add paragraph about pointing improvements including plans and impact on EVLA; add paragraph on feed/receiver windows and radomes; add paragraph on moisture and corrosion control in feeds; add information concerning waveguide transitions between feeds and receivers;

#### **2001-Nov-21, Rev B**

Incorporated additional information and change requests from S. Srikanth that included resolving many TBD's in feed specification tables. Added revised antenna optics drawing.

#### **2001-Oct-19, Rev A**

Incorporated additional information and change requests from scientific liaisons (B. Butler, V. Dhawan, & M. McKinnon)

#### **2004-Nov-18**

Update with minor revisions by J. Ruff; Items in feed specification tables filled in or modified by S. Srikanth because of the availability of information from measurements carried out **2006 Apr. 03**.

### **Summary:**

One of the EVLA requirements is to provide continuous frequency coverage from 1 to 50 GHz. Optimized feeds and low noise receiving systems will be installed to provide the maximum possible G/T performance. This chapter describes the antenna modifications and new feeds required to achieve this goal.

### **4.1 Introduction**

The VLA currently supports six cryogenic receivers. Gaps in coverage exist between bands. Continuous frequency coverage will be achieved by adding two new receivers (S- and Ka- Bands) and expanding the frequency range of the others.

The VLA uses twenty-eight, 25 m diameter Cassegrain antennas. The EVLA will use the existing VLA primary and secondary reflectors without any changes.<sup>(1)</sup> Therefore, no requirements are presented below for the reflectors. However, a geometric description of the VLA optics will be useful in the specification and design of the EVLA feed cone and feeds. The geometric description is provided in Table 1 and depicted in Figure 1.

**Table 1 VLA Optics<sup>(1)(2)</sup>**

<b>Parameter</b>	<b>Original VLA</b>	<b>Current VLA</b>	<b>EVLA</b>
Primary Reflector diameter	2500 cm	no change	no change
F/D, Primary Reflector (best fit parabola)	0.36	no change	no change
Primary Reflector focal length	900 cm	no change	no change
Secondary diameter (long axis)	235 cm	no change	no change
Distance, Primary Vertex to Secondary Vertex	847.78 cm	no change	no change
Distance, Secondary Focus to Primary Vertex	167.64 cm	no change	no change
Distance, Best Fit Prime Focus behind Secondary	52.15 cm	no change	no change
Radius of Feed Circle	97.54 cm	no change	no change
Angle Between Primary Reflector Axis and Feed Axis	8.160°	no change	no change
RMS Surface Accuracy	0.07 cm	0.04 cm <sup>(3)</sup>	no change
Distance, Primary Vertex to Vertex Room Floor	251.5 ± 10 cm	no change	no change
Feed Pattern taper at edge of Secondary	- 11.5 dB typical	no change	-13 typical

Figure 1 – VLA Cassegrain Geometry Drawing

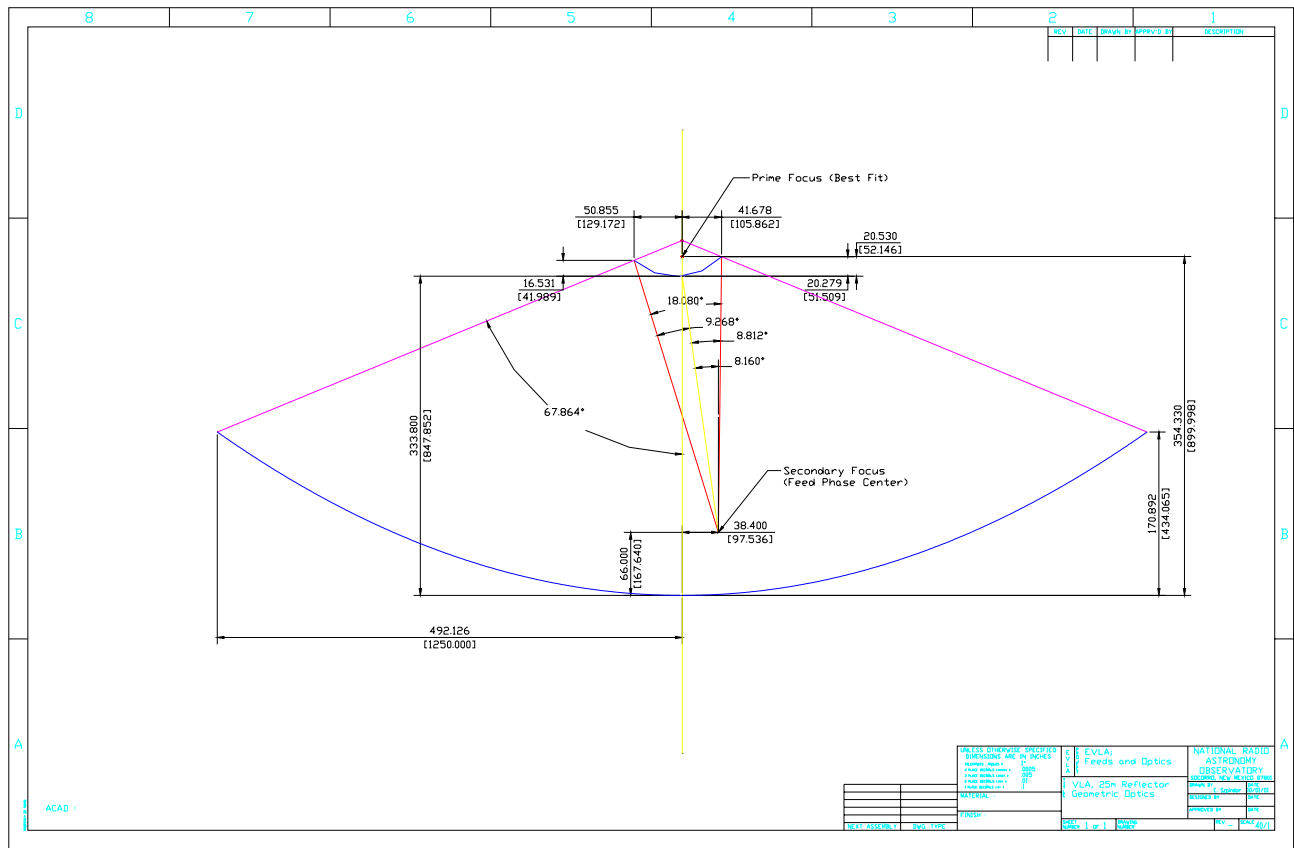

Figure 1

## 4.2 Requirements

The requirements in this section are traceable to the [EVLA Proposal](#) and the [Supplemental Information for the NSF](#) document. Additional requirement details are in Chapter 2 of the Project Book.

## 4.3 Antennas

Modification of the vertex area is necessary to accommodate EVLA enhancements. Each antenna is stripped of its Feed Support Structure, all feeds, and associated mountings. A new Feed Cone is placed over the vertex room and the new feeds are mounted therein. The L-Band feed horn is mounted outside the feed cone due to its large size.

### 4.3.1 Safety

The VLA Antennas are currently in compliance with OSHA standards for fall protection, Lock-out/Tag-out, etc. All modifications have been designed to maintain compliance.

### 4.3.2 RFI

The increased use of digital devices on the antennas may make RFI containment a priority for the EVLA, particularly in the vertex room. Therefore, the feed cone has been designed as a continuous conductive enclosure. Additionally, steps have been taken to block the RF path between the feed cone and horns. Additional measures will be considered after the required level of RF containment has been specified.

RFI considerations will be closely observed during the design of the feeds, feed cone, and any waveguide components that may be required to interface the feeds to the receivers. An EVLA system level RFI plan is currently under development. Mean while the baseline design is that the feed cone will be a conductive enclosure over the vertex

room. It will need to be conductively sealed to the vertex room. The shielding effectiveness as a function of frequency around the feed cone and vertex room should be used to generate emission strength requirements for the receiver and LO/IF components within each feed cone/vertex room. The emission level requirements will be sufficiently low such that a given antenna will not couple internally to its own receivers or radiate out to other antennas levels of emissions deemed harmful by the current ITU requirements for Radio Astronomy.

#### 4.3.3 Cabling

A watch-spring cable wrap is installed in the pedestal room. This wrap allows the fiber optic cables to accommodate the full range of antenna azimuth motion without twisting.

#### 4.3.4 Feed Cone



Figure 2 - EVLA Feed Cone Segment



Figure 3 - EVLA L, Ka, Q & K-band Feeds

##### 4.3.4.1 Structure

As originally configured, VLA X, L, and Q-Band feeds are mounted in individual enclosures. K, C, and Ku share a common enclosure. The enclosures are mounted to a structure coincident with the plane of the antenna vertex - the "feed support structure". More feeds can be positioned at the Cassegrain focus if the several enclosures are consolidated. Consolidation also simplifies receiver access, RFI shielding, and temperature control. The consolidated enclosure must provide flexibility in feed size and positioning.

The VLBA feed cone is welded aluminum, strong enough to support the feeds from its roof. This concept has been adapted for the EVLA. The EVLA feed cone (Figure 2) is constructed of 3" aluminum/polycarbonate laminated panels. The panels are glued and riveted together with extruded aluminum beams to give a continuous conductive surface for RFI containment. Feeds horns are hung from Transition Towers (Figure 3) mounted in the feed cone roof. The towers allow for feed alignment while maintaining the continuous conductive surface.

### 4.3.4.2 HVAC

The original vertex room HVAC is replaced with a new, more efficient system. The new system features a two stage R-410-A compressor, liquid-to-air heat exchangers, and a high-static air handler. The DDC controls are retained from the old system.

Vertex Room HVAC Specifications	
Supply Air Temperature	75 ± 5 °F (23.9 ± 2.8 °C)
Max ΔT between supply & return	5.4 °F (3 °C)
maximum dT/dt	1.4 °F/min (2.5 °C/min) or 10 °F/30 min (5.6 °C/30 min)
Equipment heat load	2 kW (preliminary)
Humidity Control	Not Required

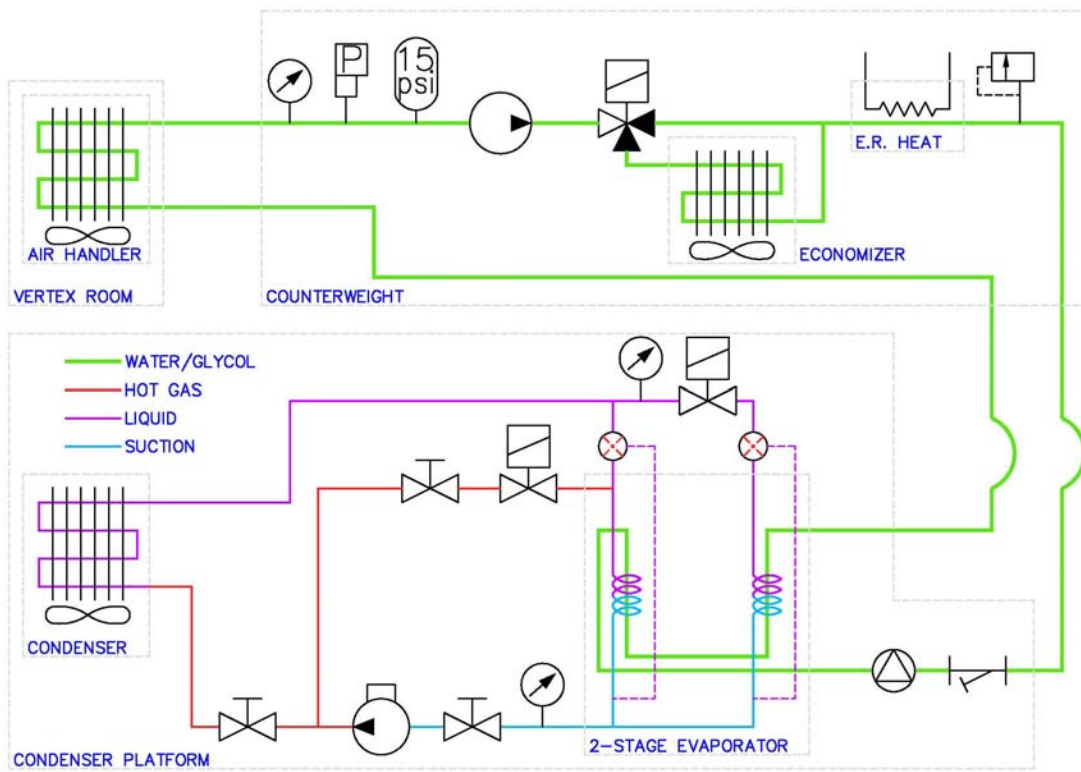

Vertex Room HVAC Schematic

### 4.3.4.3 Electrical Service

The EVLA Vertex room electronics is powered from a commercial -48 VDC power supply chassis that provides 52.5 Amps of battery backed up power. It utilizes eight 7.5A 48VDC rectifier modules configured in an n+1 redundant architecture to allow servicing without interrupting power to the load. This chassis, along with its associated lead-acid batteries, is located in the pedestal room of the antenna. It is powered from a single phase 208V, 30A AC circuit. The DC power is fed to a Square-D DC distribution panel in the vertex room on a pair of 2-0 welding cables. All of the electronic equipment in the Vertex room is fed from this panel. To minimize noise and adhere to electrical safety codes, the positive leg of this 48VDC power supply and battery system is bonded to the antenna ground at a single point in the pedestal room.

Additionally, a 3-phase 208VAC is provided for noisy and high surge current equipment. Equipment that should be on AC power includes fans, motors, pumps, feed heaters, and HVAC units.

The average, non-pointing antenna load will increase from 22kVA to 30kVA due to the addition of a third cryogenics compressor and more cryogenics refrigerators and various equipment in the Vertex room. Also, the Critical power load is now approximately 90% of the total antenna load, so there is no reason to separate the two anymore. The increased critical power load requires the use of larger transporter generators.

**4.3.5 Antenna Structural Modifications**

One structural angle in the vertex room roof is modified to make room for the L-Band feed horn. Its vertical leg is moved back approximately 1½ inches. This modification will have no effect on antenna strength or performance.

**4.3.6 Pointing Improvements**

The objective of this aspect of the project is to bring all antennas to a blind pointing accuracy of six arcsec and a referenced pointing accuracy of two arcsec. Although specified by EVLA, pointing improvements are currently not included in the scope of EVLA Phase I. Efforts to meet or exceed the EVLA pointing requirements include: replacement of azimuth bearings on a number of antennas, encoder upgrades, and diagnostics using optical telescopes.

The encoders have been upgraded in all antennas, which reduce the effect of periodic tracking errors. Encoder upgrades were performed under a separate project started in 1999 and funded through the regular Engineering and Services (ES) Operational budget.

The current VLA servo system interfaces indirectly with the EVLA system. Since the current VLA servo system electronics have become old and unreliable, an ES Operational project to replace the servo system was established to improve the reliability, configurability, and performance of the servo system. The new servo system will interface directly with EVLA and position the subreflector as well.

**4.3.7 Antenna Tracking Improvement for OTF Imaging**

TBD

**4.4 Feeds and Optics**

**4.4.1 Overview**

The requirement for providing continuous frequency coverage from 1-50 GHz on the EVLA is met by dividing the entire frequency range into eight discrete bands. The factors considered when selecting the bandwidths for each band include: (1) available technology, (2) the number of receivers/feeds, and (3) performance of the receiver/feed/polarizer at the band edges <sup>(4)</sup>. These bands are identified in Table 2 along with the bandwidth ratios. For comparison, Table 2 also includes the operational frequency range of the VLA receivers.

**Table 2 - Frequency Coverage and Bandwidth**

Band Designation	EVLA Frequency Range (GHz)	EVLA Bandwidth Ratio	VLA Operational Frequency Range (GHz)	VLA Operational Bandwidth Ratio
L	1.0 – 2.0	2.0	1.150-1.750	1.52
S	2.0 – 4.0	2.0	None Available	N/A
C	4.0 – 8.0	2.0	4.200-5.100	1.21
X	8.0 – 12.0	1.5	6.800-9.600	1.41
U	12.0 – 18.0	1.5	13.50-16.30	1.21
K	18.0 – 26.5	1.5	20.80-25.80	1.24
Ka	26.5 – 40.0	1.5	None Available	N/A
Q	40.0 – 50.0	1.25	38.00-51.00	1.34

The frequency range defined in Table 2 for each band may vary by a few percent depending on the availability of some commercial components that will be used. The existing VLA K- and Q-band receivers and feeds will be used for EVLA. Notice that Table 2 indicates that the existing K-band system does not meet the operational frequency range for EVLA, even though the receivers and feeds were designed and tested for operation over the entire 18.0 to 26.5 GHz range. It is the tunable range of the existing VLA LO/IF subsystem that limits the performance bandwidth. To interface with the new EVLA LO/IF subsystem, the existing K-band receivers will require a minor modification to change its IF output from C-band to X-band. Furthermore, notice that the existing Q-band receiver provides an operational bandwidth that exceeds the EVLA requirement. New S- and Ka-band receivers and feeds will be designed and manufactured to meet EVLA requirements. The remaining bands (L, C, X, and U) will require substantial receiver modifications and new feed designs.

The principal performance requirements for each band are provided in Table-3. A system temperature budget for each band will allocate the maximum noise temperature contribution from the antenna and various receiver components. The noise temperature requirements allocated to feeds and wave-guide components will define the insertion loss and return loss specifications for these components. Likewise, a system efficiency budget along with the noise temperature budget will define the side lobe levels and taper of the feed pattern at the edge of the subreflector

**Table 3 - Principal Performance Requirements by Band**

Band Designation	Frequency Range (GHz)	Bandwidth Ratio	System Temperature (K)	Total System Efficiency
L	1.0 – 2.0	2.0	26	0.45
S	2.0 – 4.0	2.0	26	0.62
C	4.0 – 8.0	2.0	26	0.60
X	8.0 – 12.0	1.5	30	0.56
U	12.0 – 18.0	1.5	37	0.54
K	18.0 – 26.5	1.5	59	0.51
Ka	26.5 – 40.0	1.5	53	0.39
Q	40.0 – 50.0	1.25	70*	0.34

\* At low frequency end of the band

#### 4.4.2 Polarization

All feeds will provide dual circular polarization, and they will be designed to minimize imbalances that reduce cross-polarization isolation.

#### 4.4.3 Polarization Purity

Polarization impurity will be less than 5% for each of the eight bands except at the band edges. This requirement will be used to specify the ellipticity/axial ratio, and cross-polarization isolation. Refer to section 2.2.2.5 for the requirements.

#### 4.4.4 Feed Circle Layout

Figure 4 depicts the EVLA feed layout. Feeds are arranged such that feed-to-feed interference is below -30 dB. Compensation for quadrupod sag is possible for Q, Ka and K-bands by rotating the subreflector. There is no room in the feed circle for adding a 3mm receiver. It may be possible to add 3mm by sharing the Q-Band dewar or by use of pick-off mirrors.

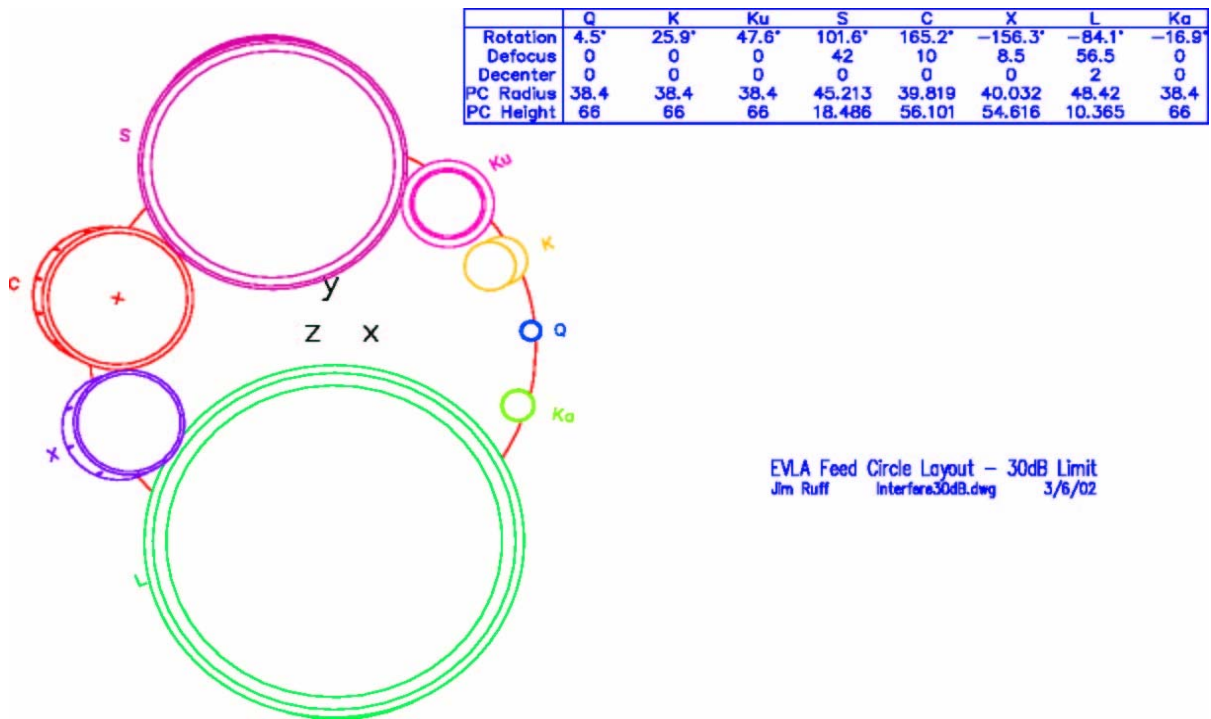

Figure 4: EVLA Feed Layout

#### 4.4.5 Windows and Radomes

The Q and Ka-Band feed horns have separate aperture and weather windows. For the other feeds, the weather window is also the aperture window.

The original VLA feeds used tuned [Teflon](#) windows. Tuned windows are not effective for our wide bandwidths. We are currently using Gortex RA-7906, but this material is somewhat lossy. Other materials are being investigated.

#### 4.4.6 Feed System Moisture and Corrosion Protection

The EVLA Feeds are designed to re-use the VLA feed [desiccators](#). This may not be effective for the L and S band horns due to their large sizes. If so, a dry air system similar to those on the VLBA antennas may be required. Investigations are underway to determine the effectiveness of positive cabin pressure in controlling feed moisture.

Exterior feed heaters are being installed. Insulation around exposed tower and feed horn surfaces will be installed later.

### 4.5 Feed System Specifications

This section contains specifications for the EVLA feeds. These specifications are traceable to one or more requirements listed in section 4.4. All polarizer components for the EVLA will be inside the receiver dewar and cooled to 15 K. Because they are physically located in the dewar, their specifications are provided in [Chapter 5](#) (Receivers). Attempts will be made to interface the feeds directly to the receivers to minimize loss, assembly length and costs. Therefore, in the following specifications it is assumed that no waveguide transitions will be required.

#### 4.5.1 General Specifications for Feeds

General specifications are those that pertain to all feeds. As the design and development process proceeds, general specifications may be tailored for specific feeds.

- (a) The optics and feed system will provide outputs for the following bands:
  - 1.0-2.0 GHz



- 2.0-4.0 GHz
  - 4.0-8.0 GHz
  - 8.0-12.0 GHz
  - 12.0-18.0 GHz
  - 18.0-26.5 GHz
  - 26.5-40.0 GHz
  - 40.0-50.0 GHz
- (b) All feeds will provide on-axis cross-polarization isolation better than -35 dB across the band.
- (c) All feeds will provide off-axis cross-polarization isolation better than -25 dB across the band regardless of the off-axis angle
- (d) All feeds will be optimized to provide the maximum possible on-axis  $G/T_{\text{sys}}$  performance across the band.
- (e) Environmental
- Operational Temperature Range (-30 C to +45 C)
  - UV protection – TBD
  - Humidity – TBD
  - Feeds will be covered to protect against moisture and creatures
  - Feed heater will be used to keep ice from forming on the feed covers

#### 4.5.2 L-band Feed (1.0-2.0 GHz)

The VLA frequency coverage for L-band is from 1.150 to 1.750 GHz. Full band operation requires a feed substantially larger in both length and aperture than the current VLA L-Band horn. The new wide-band design must fit into the limited space available the feed circle, while properly illuminating the VLA sub-reflector.

**Table 4 – L-Band Feed Specifications**

Item	Nomenclature
Type	Compact Corrugated ((profiled horn)
Frequency Range	1.0 –2.0 GHz
Polarization	Dual circular
Return Loss	< -25.0 dB
Cross-polarization Isolation (on-axis)	< -35.0 dB
Cross-polarization Isolation (off-axis)	< -25.0 dB
Taper (1.5 GHz)	- 12.0 +/- 0.5 dB
Taper (1.0 and 2.0 GHz)	-12.0 +/- 2.0 dB
First Side Lobe Level (max)	< -30.0 dB (rel. to main lobe)
Distance from Phase Center to Aperture (1.2, 1.6, 2.0 GHz)	43 in., 81 in., 123 in.
Length	155 in.
Aperture Diameter	62.1 in.
Feed Horn Weight	760 lbs.

#### 4.5.3 S-band Feed (2.0-4.0 GHz)

The VLA does not have a receiver for S-band. The new wide-band design must fit into the limited space of the feed circle, while properly illuminating the VLA subreflector.



**Table 5 – S-band Feed Specifications**

Item	Nomenclature
Type	Compact Corrugated profiled horn)
Frequency Range	2.0 –4.0 GHz
Polarization	Dual circular
Return Loss	< -25.0 dB
Cross-polarization Isolation (on-axis)	< -35.0 dB
Cross-polarization Isolation (off-axis)	< -25.0 dB
Taper (3.0 GHz)	-13.0 +/- 0.5 dB
Taper (2.0 and 4.0 GHz)	-13.0 +/- 1.0 dB
First Side Lobe Level (max)	< -30.0 dB (rel. to main lobe)
Distance from Phase Center to Aperture at 3.0 GHz	80 in.
Length (max)	150 in.
Aperture Diameter	42 in.
Weight (max)	400 lbs.

**4.5.4 C-band Feed (4.0-8.0 GHz)**

The VLA frequency coverage for C-band is from 4.200 to 5.100 GHz . The new wide-band design must fit into the limited space of the feed circle, while properly illuminating the VLA subreflector.

**Table 6 – C-band Feed Specifications**

Item	Nomenclature
Type	Compact Corrugated (profiled horn)
Frequency Range	4.0 –8.0 GHz
Polarization	Dual circular
Return Loss	< -25.0 dB
Cross-polarization Isolation (on-axis)	< -35.0 dB
Cross-polarization Isolation (off-axis)	< -25.0 dB
Taper (6.0 GHz)	-13.0 +/- 0.5 dB
Taper (4.0 and 8.0 GHz)	-13.0 +/- 1.0 dB
First Side Lobe Level (max)	< -30 dB (rel. to main lobe)
Distance from Phase Center to Aperture at 6.0 GHz	40 in.
Length	66.375 in.
Aperture Diameter	22.1 in.
Weight	101 lbs.

**4.5.5 X-band Feed (8.0-12.0 GHz)**

The VLA frequency coverage for X-band is from 6.800 to 9.600 GHz. The new wide-band design must fit into the limited space of the feed circle, while properly illuminating the VLA subreflector.

**Table 7 – X-band Feed Specifications**

Item	Nomenclature
Type	Linear Taper Corrugated
Frequency Range	8.0 –12.0 GHz
Polarization	Dual circular
Return Loss	< -25.0 dB
Cross-polarization Isolation (on-axis)	< -35.0 dB

Cross-polarization Isolation (off-axis)	< -25.0 dB
Taper (10.0 GHz)	-14.0 +/- 0.5 dB
Taper (8.0 and 12.0 GHz)	-14.0 +/- 1.0 dB
First Side Lobe Level (max)	< -30.0 dB (rel. to main lobe)
Distance from Phase Center to Aperture at 10 GHz	36 in.
Length	50.7 in.
Aperture Diameter	18.5 in.
Feed Horn Weight	72 lbs.

#### 4.5.6 Ku-band Feed (12.0-18.0 GHz)

The VLA frequency coverage for Ku-band is from 13.500 to 16.300 GHz. The new wide-band design must fit into the limited space of the feed circle, while properly illuminating the VLA subreflector.

**Table 8 – Ku-band Feed Specifications**

Item	Nomenclature
Type	Linear Taper Corrugated
Frequency Range	12.0 –18.0 GHz
Polarization	Dual circular
Return Loss	< -25.0 dB
Cross-polarization Isolation (on-axis)	< -35.0 dB
Cross-polarization Isolation (off-axis)	< -25.0 dB
Taper (15.0 GHz)	-14.0 +/- 0.5 dB
Taper (12.0 and 18.0 GHz)	-14.0 +/- 1.0 dB
First Side Lobe Level (max)	< -30.0 dB (rel. to main lobe)
Distance from Phase Center to Aperture at 15.0 GHz	23 in.
Length (max)	33 in.
Aperture Diameter (max)	14 in.
Weight (max)	Xx lbs. TBD

#### 4.5.7 K-band Feed (18.0-26.5 GHz)

The VLA frequency coverage for K-band is from 20.8 – 25.8 GHz. The existing wide-band feed and receiver must fit into the limited space of the feed circle, while properly illuminating the VLA subreflector. The existing feed and receiver are limited in frequency operation by the LO/IF system in the VLA. Full band functionality will be possible with the EVLA LO/IF system.

**Table 9 – K-band Feed Specifications**

Item	Nomenclature
Type	Linear Taper Corrugated
Frequency Range	18.0 –26.5 GHz
Polarization	Dual circular
Return Loss	< -25.0 dB
Cross-polarization Isolation (on-axis)	< -35.0 dB
Cross-polarization Isolation (off-axis)	< -25.0 dB
Taper (22.25 GHz)	-13.0+/- 0.5 dB
Taper (18.0 and 26.5 GHz)	-13.0 +/- 0.5 dB
First Side Lobe Level (max)	< -30.0 dB (rel. to main lobe)
Distance from Phase Center to Aperture at 23.0 GHz	16 in.
Length	20.844 in.

Aperture Diameter	8 in.
Weight	10 lbs. TBD

#### 4.5.8 Ka-band Feed (26.5-40.0 GHz)

The VLA provides no frequency coverage for Ka-band. The new wide-band design must fit into the limited space of the feed circle, while properly illuminating the VLA subreflector.

**Table 10 – Ka-band Feed Specifications**

Item	Nomenclature
Type	Linear Taper Corrugated
Frequency Range	26.5 –40.0 GHz
Polarization	Dual circular
Return Loss	< -25.0 dB
Cross-polarization Isolation (on-axis)	< -35.0 dB
Cross-polarization Isolation (off-axis)	< -25.0 dB
Taper (33.25 GHz)	-13.0 +/- 0.5 dB TBD
Taper (26.5 and 40.0 GHz)	-13.0Xx +/- 1.0 dB TBD
First Side Lobe Level (max)	< -30.0 dB (rel. to main lobe)
Distance from Phase Center to Aperture at 33.0 GHz	10.5 in.
Length	14.3 in.
Aperture Diameter	5.4 in.
Feed Horn Weight	5 lbs. TBD

#### 4.5.9 Q-band Feed (40.0-50.0 GHz)

The VLA frequency coverage for Q-band is from 38.0 to 51.0 GHz. This existing wide-band feed and receiver must fit into the limited space of the feed circle, while properly illuminating the VLA subreflector.

**Table 11 – Q-band Feed Specifications**

Item	Nomenclature
Type	Linear Taper Corrugated
Frequency Range	40.0 –50.0 GHz
Polarization	Dual circular
Return Loss	<- 25.0 dB
Cross-polarization Isolation (on-axis)	< -35.0 dB
Cross-polarization Isolation (off-axis)	< -25.0 dB
Taper (45.0 GHz)	-13.0 +/- 0.5 dB
Taper (40.0 and 50.0 GHz)	-13.0 +/- 1.0 dB
First Side Lobe Level (max)	< -30.0 dB (rel. to main lobe)
Distance from Phase Center to Aperture at 45.0 GHz	5.5 in.
Length	7 in.
Aperture Diameter	3 in.
Feed Horn Weight	1 lb. TBD

#### References:

1. P. J. Napier et al, “The Very Large Array...,” IEEE Proceedings, Vol 71, No. 11, pg 1295, November 1983.
2. VLA “Green Book”, pg 1-10, 4/82
3. Rick Perley: Q-band holography results.
4. S. Srikanth, Electromagnetic Analysis of the VLA Antennas at L-band, NRAO Memo, 20 May 1999.

5. B. Butler, Some Issues for Water Vapor Radiometry at the VLA, VLA Scientific Memo. No. 177, 1999