

EVLA Monitor and Control System

Wayne Koski, Rich Moeser, George Peck, James Robnett,
Bruce Rowen, Kevin Ryan, Bill Sahr, Ken Sowinski
Last changed 2003-Aug-22

Revision History

-
- 2001-July-16: Initial release
 - 2001-Sept-25: Initial draft of text
 - 2001-Oct-16: Minor cleanup & revisions
 - 2001-Nov-20: Links to Requirements Documents added
 - Section for Correlator Requirements added
 - Link to EVLA Backup Monitor And Control System document added
 - 2002-May-31 Major revision. Entire chapter reorganized and updated
 - 2003-Aug-22 Major revision. All sections reviewed and updated. Some sections deleted, new sections added
-

9.1 Introduction

This chapter of the Project Book has been organized by subsystems, with allowances for topics that do not fit within that scheme. Four subsystems have been identified – Antenna Monitor and Control (AMCS), Correlator Monitor and Control (CMCS), the Operational Interface System (OIS), and the EVLA Monitor and Control Network (MCN). The sections covering the four subsystems all have a similar structure:

- 9.a Subsystem Name
 - 9.a.b Subsystem General Description
 - 9.a.c Subsystem Requirements
 - 9.a.c.1 Subsystem Hardware Requirements
 - 9.a.c.2 Subsystem Software Requirements
 - 9.a.d Subsystem Design
 - 9.a.d.1 Subsystem Hardware Design
 - 9.a.d.2 Subsystem Software Design

9.2 EVLA Software

Over the course of the last year a model for the EVLA software has emerged which posits a relationship between EVLA Monitor and Control Software and the e2e software that many find unexpected, and that diverges from the usual model for monitor and control systems. The unexpected component of the model is that the final, mature version of the EVLA Monitor and Control System will be dependent upon e2e developed software elements for certain critical functions, without which the monitor and control system will not function. The relationship among the EVLA M&C components and the e2e components is illustrated in the diagram given below. The gold tone (darker gray) boxes represent software to be developed by the EVLA M&C group. The blue (lighter gray) boxes represent elements to be developed by the e2e group. The multicolored (grayscale) boxes represent elements that are considered to be part of the e2e effort, but whose development will be a joint M&C and e2e effort.

EVLA M&C and e2e software

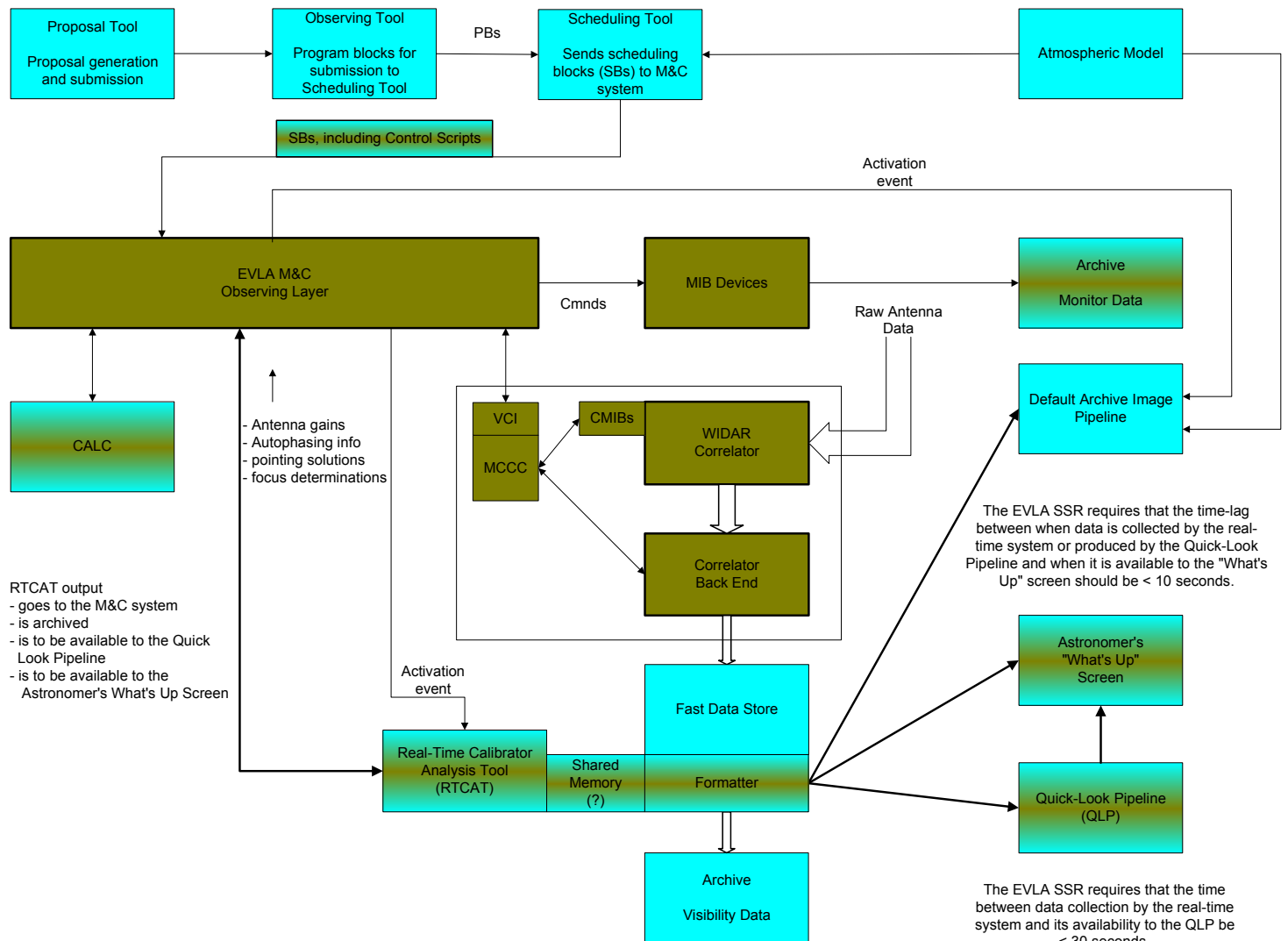

/users/bsahr/EVLA/architecture_design/overall_design/evla_m&c_e2e.vsd, 8/2003

The elements of the e2e software that are needed by the monitor and control system are 1) the control scripts (top left portion of the diagram), 2) the monitor data archive (right hand side of the diagram), 3) Calc (left hand side), and 4) the real-time calibrator analysis tool (RTCAT) (bottom center). Without these elements, the EVLA Monitor and Control System simply will not function. An initial version of the monitor data archive is ready to go, and has been tested using VLA data reformatted to EVLA standards. Of the remaining elements, it should be noted that all of these software elements are multicolored boxes, denoting a joint M&C and e2e development effort. If necessary, for whatever reason, the EVLA M&C group is prepared to absorb all of the effort to develop initial versions of these software elements.

9.2.1 EVLA Software, Management and Organization

The management and organization of the EVLA software effort has been reformulated to better serve the needs of the project. First and foremost, the position of Project Manager for EVLA Software has been created. The Project Manager will be responsible for all EVLA software – both M&C and e2e. Over the past year it became clear that closer coordination and synchronization between the M&C effort and the e2e effort was needed, especially in light of the dependency of the monitor and control software on certain e2e elements. The creation of a Project Manager

position for EVLA Software should significantly increase the levels of communication, cooperation, and synchronization between the M&C and e2e groups, and provides a single point of responsibility for all EVLA software. Another new development was the creation of the position of EVLA Software Project Scientist. This position is distinct and different from, and will supplement the position of EVLA Project Scientist. The EVLA Software Project Scientist will be responsible for defining the scientific requirements for the EVLA software, and for testing and acceptance of the EVLA software.

9.2.2 EVLA Software Requirements

As of a year ago, a collection of 5 requirements documents, internally generated by members of the Socorro Computer Division, plus an early (September 2000) memo on scientific requirements for the real-time system constituted the total of the written requirements available to the EVLA Monitor and Control group. Over the past year, that situation has changed significantly. The scientific community within NRAO and Array Operations at NRAO has produced, or are in the process of producing, a series of requirements documents that represent significant input from the users of the EVLA. The documents consist of the following:

- EVLA-SW-001, EVLA e2e Science Software Requirements, April 15, 2003
- EVLA-SW-002, EVLA Data Post-Processing Software Requirements, (Draft), July 3, 20003
- EVLA-SW-003, EVLA Array Operations Software Requirements, June 6, 2003
- EVLA-SW-004, EVLA Engineering Software Requirements, August 8, 2003
- EVLA-SW-005, EVLA Science Requirements for the Real-Time Software (effort to begin 9/2003)

The development of the fifth document, on the scientific requirements for the real-time software, is scheduled to begin late August or early September 2003. Until that document is developed, EVLA Memo No 15, Scientific Requirements for the EVLA Real-Time System, September 26, 2000, is being used.

The high level requirements specified in these documents are being combined into a single System Requirements Specification for the EVLA Software System. That document will be submitted to the EVLA Change Control Board, and will become the definitive requirements document for the EVLA. The Systems Requirement Specification will be placed under revision control, and changes to that document will require the approval of the EVLA Change Control Board.

Once the System Requirements Specification of the EVLA Software System has been completed, the plan is to

1. Tie each high level requirement to one or more boxes in a revised, re-evaluated diagram of the “Principal EVLA Subsystems” diagram (unrevised version given below),
2. Describe the functionality of each box, the data flow within each box, and the data flowing across the interfaces to each box,
3. Prioritize the functional elements associated with each box,
4. Locate and describe all existing design and implementation information and existing software that relates to the functionality associated with each box,
5. Produce an overall design and development plan that satisfies the requirements

9.3 Antenna Monitor & Control Subsystem (AMCS)

The Antenna Monitor and Control Subsystem is that portion of the EVLA Monitor and Control System responsible for operating the array of antennas, both the new EVLA antennas as they come online and the existing VLA antennas during the transition phase. The AMCS may also be required to operate some of the nearby VLBA antennas and, if Phase II of the VLA Expansion Project occurs, the New Mexico Array (NMA) antennas as well.

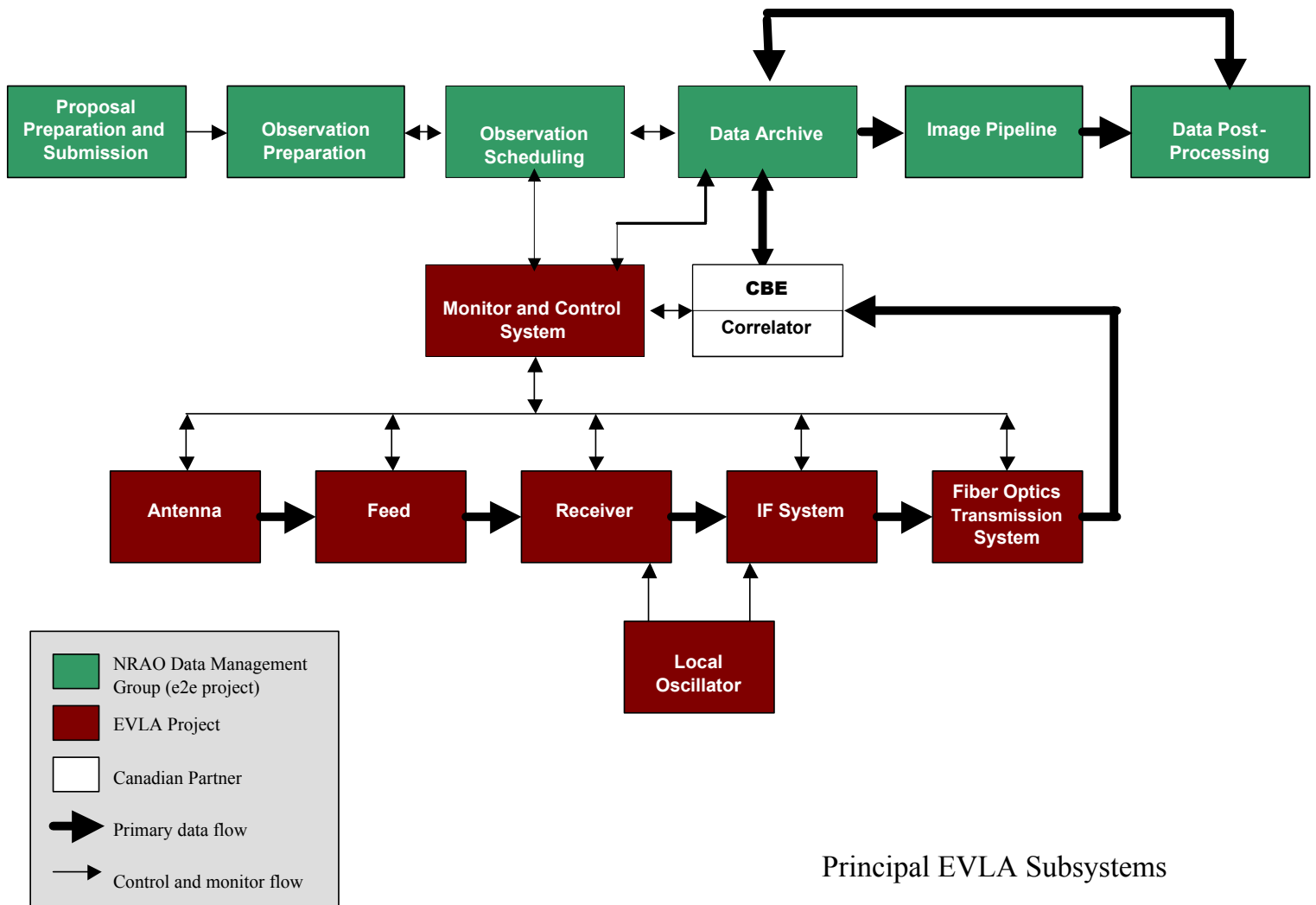

9.3.1 AMCS General Description

Physically the Antenna Monitor and Control Subsystem will consist of processors located throughout the system from the Control Building at the VLA site to within the EVLA antennas themselves. Processors residing in the Control Building will have no limits on size and complexity and will take the form of high reliability desktop and rackmount machines. Processors located within the antennas will be small micro-controller type processor boards with minimal RAM and low clock speeds to help reduce RFI. These micro-controllers will interface the components of the antenna to the rest of the monitor and control system; they are referred to as Module Interface Boards (MIBs).

All AMCS processors, including the MIBs within the antennas will be networked using Ethernet over fiber-optic cable.

9.3.2 AMCS Requirements

9.3.2.1 AMCS Hardware Requirements

9.3.2.1.1 Minimum RFI

The most basic AMCS hardware requirement is low emission of RFI. Minimum emission of RFI is necessary in order to prevent the scientific data from being corrupted by noise from the AMCS.

9.3.2.1.2 Ethernet

The use of Ethernet as the bus is considered a requirement because it allows the entire AMCS to use one bus, there is COTS equipment available, it is maintainable due to widespread commercial use, it allows addressing by slot, and it is well suited for object-oriented programming.

9.3.2.1.3 Data Rates

The maximum data rate from an EVLA module is estimated to be 128 Kbits/sec, and the maximum data rate from an EVLA antenna is expected to be 200 Kbits/sec. It is possible that most of the monitor data from an antenna will be from a single module, where the total power detectors are located.

9.3.2.1.4 Timing

Reconfiguration commands sent by the ACMS must begin not more than 100 μ s after the intended implementation time. This requirement will necessitate the queuing of commands at the MIB before the scheduled implementation time.

The monitor and control system must be able to keep absolute time to a resolution of better than 10 ms.

9.3.2.1.5 MIB (Module Interface Board) Requirements

The design of the MIB was largely driven by three main requirements. Additional important design requirements are also necessary for the MIB to perform its duties in a robust manner.

The three main requirements were 1) the choice of TCP/IP over Ethernet as the communication protocol, 2) low RFI characteristics, and 3) small board size. The RFI emissions requirement limited the choice for the microprocessor and on-board electronics. The small board size is especially important, given space limitations, which are also affected by the low RFI emission requirement.

Additionally, the MIB must utilize both serial and parallel communications to the EVLA devices. It must have the intelligence to implement monitor and control tasks in the modules and devices, and must sometimes be part of control loops. Periodically or on demand, the MIB must be able to send back monitor data to other points on the network. It must be possible to load new software into the MIB in the field, without having to send a technician out to the antenna. In order to synchronize commands and send monitor data on a periodic basis, the MIB must be able to receive a timing signal and keep track of time. A watchdog timer must be implemented so that the MIB will recover if the processor hangs up. The MIB must be fused. A separate maintenance port that communicates via RS-232 must be included. There must be power indicator LEDs to indicate the presence of each voltage. A test LED must be included to facilitate programming and debugging.

9.3.2.2 AMCS Software Requirements

The current version of the Antenna Monitor and Control Subsystem Requirements document can be found at <http://www.aoc.nrao.edu/evla/techdocs/computer/workdocs/index.shtml>, under the title “Antenna Monitor & Control Subsystem Preliminary Requirements Specification”.

While the requirements specification document referenced above contains a detailed description of all of the requirements imposed on the AMCS, it is worth mentioning here the few major requirements that have the most influence in ‘shaping’ the AMCS software design.

- **Heterogeneous Array.** The EVLA will, from the onset, consist of different types of antennas. During the transition phase this will be the older VLA types as well as the new EVLA types. Eventually VLBA and New Mexico Array (NMA) antennas may be added as well. Because of this, the design of the AMCS must accommodate differences in antenna hardware.
- **Ethernet Based Communications.** The EVLA will be a highly networked system; even the antenna subcomponents will utilize an Ethernet field bus with each subcomponent having its own IP address. Ethernet and the associated network communications protocols (IP/TCP/UDP) will require that the AMCS design accommodate this higher level of data communications between the various components of the system.
- **Widespread Operational Interface.** The EVLA will be operated (at various levels) from a potential variety of sources: normal programmed observing from the e2e system, Interactive Observing, control from the AOC and other NRAO entities, subcomponent operation from the technician's workbench and even monitoring from over the Internet at large. The AMCS design must serve a variety of users from a variety of physical locations.
- **Transition Phase Operation.** The transition from the current VLA antennas into the EVLA antennas will take a number of years to complete. The AMCS must be designed so that during this time 1) both antenna types will be operated together under one control system, 2) system down time is minimized and 3) transition specific software (throw-away) code is minimized.
- **Real-Time Requirements.** There are few hard real time requirements imposed on the AMCS but those that do exist most certainly must be accounted for in the AMCS software design. They are:
 - 100 μ Sec command start latency. This means that a command must be initiated at the hardware within 100 μ Sec of its scheduled start time.
 - For EVLA antennas, to maintain a sub-arcsecond level of pointing accuracy, the antenna position must be updated every 50 milliseconds.
 - Frequency change within band to be completed within one second.
 - 'Nodding' source switch rate of once per ten seconds.
 - For the most extreme case of OTF mosaicing, the correlator will require new delay polynomials at the rate of 10 per second.

9.3.3 AMCS Design

The AMCS is being designed with the intent of creating not only a system that is state-of-the-art with today's technology but will also 'scale' with new technology as it comes about. To achieve this scalability, the system is being designed with modularity always in mind. By doing so, the system will develop into a collection of 'plug-and-play' components that can be replaced without causing adverse affects on the rest of the system.

The ultimate goal of this approach is to create a system that 20 years from now will not be locked into 20-year old technology.

9.3.3.1 AMCS Hardware

9.3.3.1.1 General Description

The hardware part of the AMCS will consist of a MIB (Module Interface Board) and various other boards to interface the MIB to devices.

9.3.3.1.2 Module Interface Board (MIB)

Every EVLA module or device will contain a Module Interface Board (MIB). The MIB is the interface between the antenna control computer and any module or device electronics in the EVLA. Command and Monitor information will be sent between the MIBs and network computers over 100BaseFX full duplex Ethernet. Communications between the MIB and EVLA devices are primarily carried out via Serial Peripheral Interface (SPI) and General Purpose I/O (GPIO) lines (parallel communications).

The core of the MIB is the Infineon TC11IB microprocessor. This chip incorporates several peripheral functions that often require separate chips. These include the Ethernet controller, 1.5 Megabytes of on-chip memory, a SPI port, and two serial ports. On-chip timers satisfy the timing requirements of the MIB. The TC11IB requires a 12 MHZ crystal oscillator that is multiplied, on chip, to create a 96 MHZ system clock. It has a watchdog timer to ensure that the program does not hang.

A 64 Megabit Flash memory chip is used to store the program image(s) for the TC11IB. The MIB can run from the Flash memory, however it is planned that the program will be transferred from Flash to memory on the TC11IB during the boot sequence. It has been shown that RFI is minimized by running from on-chip memory. It will be possible to load new program code into the Flash memory from a network computer via Ethernet. The on-chip memory will also be used to store commands and monitor requests from the antenna computer.

The voltage regulator chip on the board includes power management features that reset the TC11IB if the voltages fall below their nominal values. During the power-up sequence, the reset line of this chip keeps the TC11IB in the reset state until all voltages have risen to the correct values. All power supply voltages on the MIB, both input and output, are fused for protection against shorts.

The MIB will receive a 19.2 HZ system heartbeat for timing purposes. A computer on the network will be able to tell the MIB to start keeping absolute time at the arrival of the next system heartbeat. A timer on the TC11IB will then be used to keep time. This will make it possible to queue commands in advance, to be executed by the MIB at a specified time.

The MIB will detect the slot into which it is plugged. This feature eliminates the need to change the module address when the module is moved.

The MIB will not be used to ensure the safety of any EVLA modules or devices. Each module or device must be designed such that it will be protected even in the absence of a MIB.

9.3.3.1.3 Battery Backed Utility

EVLA modules at the antenna and control building, that are powered from the system 48 volt supply, will remain powered for a specified amount of time in the event of a commercial power outage. The specified amount of time will be long enough for the generators to start operating and restore power. In the event that the generators do not start operating, there will be plenty of time for computers in the control building to determine the state of each antenna before the UPS units in the EVLA antennas lose power.

9.3.3.1.3 Voice Communications

Voice communications between an antenna and the outside world will be enabled via VoIP (Voice over IP). The system will carry standard telephone voice communications for an antenna over the Monitor and Control Network link in TCP/IP form. It is predicted that the voice traffic will not hinder antenna control traffic. A spare fiber pair is available if such turns out not to be the case.

The VLA and AOC phone systems are maintained by New Mexico Tech (NMT). Implementing full voice communications between an EVLA antenna and legacy phone systems will require cooperation with New Mexico

Tech. NMT is currently implementing a VoIP system. We (NRAO) will be able to tap directly into this system, relieving us of both the need to purchase transition hardware and the need to manage the system. Currently only 100Base-T (twisted pair) IP phones are available. Phones will be connected via a media converter to the antenna switch until fiber based phones are available.

9.3.3.2 AMCS Software

The AMCS software design philosophy is that of ‘scalability through modularity’. Vendor specific technologies are being avoided in favor of more industry-wide approaches in order that no part of the software system will have to rely on any one particular vendor for its future growth. An example of this is favoring the use of SOAP over CORBA for software object brokering over the network.

The one major exception to this rule is the operating systems chosen for the various processors. While versions of real-time Linux (an OS with broad industry support) do exist, it was necessary to select a vendor-specific RTOS for the MIB. Real-time Linux requires too much RAM to be accommodated by the memory available to the MIB processor.

All but the low-level hardware driver software will be designed using Object Oriented techniques. Because of the highly networked, distributed nature of the AMCS system, it is hoped that it will be possible to use Java throughout the AMCS system in all but the hardware driver areas. Java is a language designed from the onset around networking and distributed processing. Java was also designed to be a language for large systems with its packaging structure and built in documentation generation. It is estimated by developers experienced in both languages that software development in Java takes roughly half the time as software development in C++*.

*” Thinking in Java”, 2nd edition, Revision 12; ©2000 by Bruce Eckel

9.3.3.2.1 AMCS Software, General Description

This section describes the AMCS software in general terms with loose reference to the major requirements that the design seeks to satisfy.

Ethernet Communications. All of the processors in the system will incorporate an Operating System capable of providing the various Ethernet and IP protocols. This means that even the otherwise simple MIBs will have to support an OS capable of higher level network protocols such as TCP/UDP/IP and possibly others such as HTTP and XML.

Data communications between the various devices will become more generic and higher-level in nature as opposed to dedicated field busses like the VLBA’s MCB and HCB where simple address/value pairs of binary data are communicated.

Heterogeneous Hardware. AMCS design takes advantage of the fact that every component of the system, including the subcomponents within the antennas, are ‘intelligent’ devices with a network presence, indeed each with its own IP address. Because of this, the functionality of the system as a whole can be distributed among the various devices that make up the physical system.

Distributed processing allows the design of a modular system separated into its various functional components of arrays, sub-arrays, antennas and antenna sub-components (such as servos, LO, etc.). Each of these components will contain its own processor which will present the ‘front-panel’ of that component to the rest of the system while hiding the implementation details of the component from the system. The implementation details will be encapsulated.

Encapsulation allows the system to meet the requirement of being able to accommodate heterogeneous antenna types and associated hardware. Components can be sent generic, high-level type commands from the system controller. For example, two different type servos, each with a different position resolution, can both be commanded to say 47.0° by sending the floating-point value of 47.0 to each instead of having to send two different binary values corresponding to the resolution of each.

Variety of Users from a Variety of Locations. The modular components of the AMCS will be fully autonomous. They will accept commands that are of a ‘what-to-do’ nature as opposed to ‘how-to-do-it’. Each component will also monitor itself. It is a trivial matter, for example, for a component to monitor the voltage reading of its own power supply. It can sample the values much faster than if they were instead sampled from across the network by a central processor. This has the advantage that the archive and monitor displays will not be ‘clogged’ with trivial normal-valued monitor data.

A system of autonomous components means that an antenna or antenna subcomponent can be fully operated separately from the rest of the system such as when undergoing development and maintenance.

Because components will be autonomous they can act as servers for their particular functions. This allows the system to be designed as a type of client/server system. Clients can request the services of any of the components that make up the system. This architecture makes for a very flexible system as seen by external systems. User Interface clients can be made ‘thinner’ (less application specific); in fact, web browsers will probably be used to interface some parts of the system.

Real-Time Considerations. Because of the way the AMCS is being designed, real-time operations can take place where the action is required. Instead of a central processor issuing real-time commands over several kilometers of network, the commands can be initiated within the component itself. This implies that configuration parameters will have to be sent to the various components ahead of time so that they will be ready for implementation time. Just how far ‘ahead of time’ and whether just one or blocks of several configuration changes will be sent out to the devices is still under discussion with the e2e group since it affects their Dynamic Scheduling process. It will probably work out that ‘minutes’ worth of configuration information will be queued with the ability to cancel or replace the current set for such occurrences as emergency target-of-opportunity observations.

9.3.3.2.2 AMCS Systems Software & Middleware

While real-time operations are few, the need for a real-time operating system (RTOS) exists for the processors in the AMCS. The driving force for the MIB was not only for actual real-time operations but also to obtain the necessary networking functions (e.g. the TCP/IP stack) while maintaining a small overall memory footprint. Because of the newness of the MIB’s processor and memory size limitations, choices for a MIB RTOS are quite limited compared to that of the other processors that will be used in the system. After much research, ATI’s Nucleus PLUS RTOS was chosen.

Several technologies are currently being investigated for the so-called middleware. This middleware will essentially be the AMCS’s interface to the Operational Interface System (OIS). As such, this area of software is being investigated by both the AMCS and OIS designers. It is a goal to use COTS software with industry wide support and popularity if possible.

The AMCS and OIS will be designed to work together to form a User Interface that will be malleable by the users themselves and that will change with the AMCS system without requiring re-programming. To accomplish this, the middleware will have to allow the OIS to discover the attributes and capabilities of the AMCS’s components and be able to operate them directly. A system of plain-text message passing via XML is currently being developed.

Whereas interfaces that utilize some form of remote procedure calling (CORBA, RMI, etc) can only be used between two computers, this plain-text message passing interface allows three types of communication with a Device:

1. Human-to-computer. This is direct communications with a Device via Telnet or Web-browser session. This represents communications using the ‘thinnest’ clients available. The advantage being that almost all computer users have access to a shell window or web browser and will therefore be able to communicate with a device without special software.
2. Script-to-computer. These are lists of instructions in plain-text and XML that can be saved as files and sent over the interface to a Device. Observations and maintenance routines performed periodically will utilize this method.
3. Computer-to-computer. Generic and specialized user interfaces on client processors will communicate with a Device. This represents more specialized software clients that users such as operators and maintenance technicians will have to perform their daily tasks. Automated data analysis, plotting and logging are some of the functions that will use the interface in this manner.

All Devices in the system will support this interface so that every component of the system will be accessible by the three methods mentioned. This means any Device in the system - from the whole array down to a switch buried deep within an antenna – could be controlled by technician from his terminal, or be sent a list of configuration instructions.

9.3.3.2.3 AMCS Application Software

AMCS Software is being designed using Objected Oriented Design (OOD) principles. Each physical component of the system will map directly to a software object called a ‘Device’. Each software Device will represent the functionality of the hardware to which it is connected. In the AMCS, everything is a Device from the ArrayDevice (array of antennas) to a component device within an antenna.

Devices communicate with the system (parent devices or client application) via a DeviceServer class. There is one, and only one DeviceServer per physical processor but zero to many Devices per processor. This means that every MIB will have one DeviceServer and zero or more Devices. The DeviceServer provides the communications services (such as the network communications layer, and the plain-text message passing protocol) leaving the Devices to ‘concentrate’ on their jobs of representing their hardware. Most MIBs will likely have one or two devices but some will have many. The Interim Control and Monitor Processor (discussed in the section on Transition Planning) DeviceServer is responsible for more than 150 Devices.

As mentioned earlier, generic User Interfaces will be able to ‘discover’ the various components of the system thereby eliminating the need for ‘hard-coding’ lists of devices (and their characteristics) into client applications. This in turn allows the system to change physically without necessitating change at user levels of software. Text-based property files are being used to describe Devices and their associated control and monitor points. This approach allows this addition or removal of control and monitor points and other attributes dynamically, without the need for recompilation. This is an important advantage considering there will be over 900 MIB processors deployed.

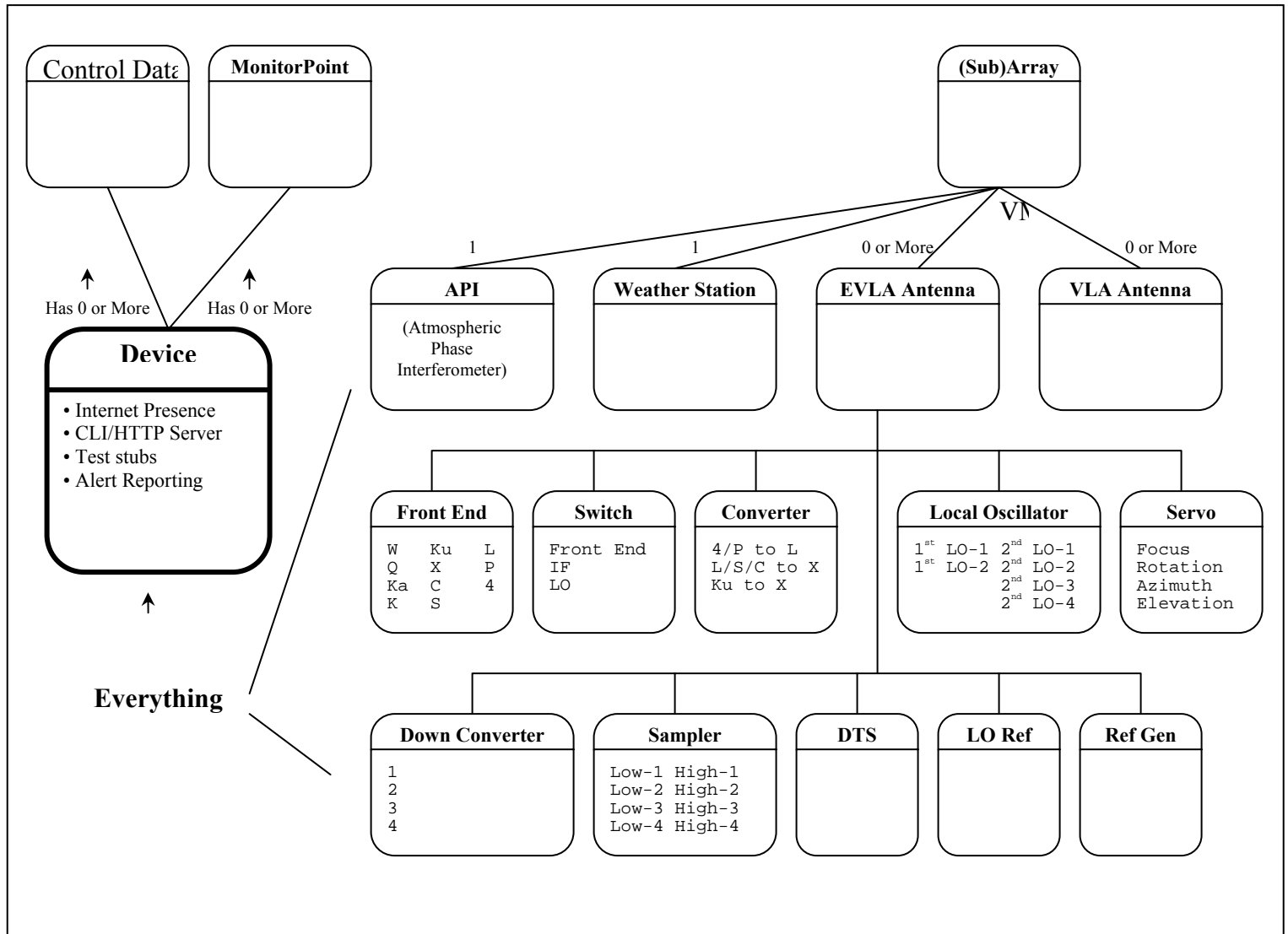

The component classes will communicate with the low-level hardware ‘driver’ software. This driver software communicates directly with hardware via the processor’s I/O ports. The interface between the low-level, driver software and the higher-level component objects will involve the transformation of raw control and monitor data into ControlPoint and MonitorPoint objects. It will also involve the translation of object method invocations into calls to the associated low-level driver routines. These driver routines such as specific hardware control functions and various diagnostic and test functions will be written and maintained in close coordination with hardware engineering personnel.

9.3.3.2.3.1 MIB Software

The basic model for the MIB software is that it will consist of a general framework, common to all MIBs (the aforementioned DeviceServer) plus module specific software. The DeviceServer will implement a Data Port that will be used to broadcast monitor data, warnings, alarms, and error messages, and a Service Port that will be used to obtain information about MIB-connected devices, and to accept commands for devices. A thin layer, over UDP, has been defined as the protocol for the distribution of monitor data. That protocol specification is contained in the document

“MIB Broadcast Stream Specification V1.0”, which can be found on the Computing Working Documents web page (<http://www.aoc.nrao.edu/evla/techdocs/computer/workdocs/index.shtml>). Working code that implements the MIB broadcast stream specification exists, and has been tested on a prototype MIB board. A specification for the Service Port is currently under development. Code that implements what is expected to be the core of the Service Port functionality has been developed, and has also been tested on a prototype MIB board.

9.4 Correlator Monitor and Control Subsystem (CMCS)

9.4.1 CMCS General Description

The CMCS will provide Correlator monitor and control through a network of distributed processors and processes. General access to this network will be through a “Virtual Correlator Interface” (VCI) that will provide a unified and flexible means of integrating the Correlator into the overall EVLA system.

Some details of the VCI and scheduling may be found in NRC-EVLA memo #16, “Scheduling and Activating the Configuration Data” by Sonja Vrcic, the recent Software Engineering hire at DRAO in Canada.

http://www.drao-ofr.hia-iha.nrc-cnrc.gc.ca/science/widar/public/NRC_EVLA_memo016.pdf

A separate layer above the VCI will provide extensive diagnostics and control primitives for engineering and technical support. It is the intent of this separate layer to provide the necessary tools for Correlator development during the construction stage.

9.4.2 CMCS Requirements

A more detailed description of CMCS requirements may be found in EVLA memo #15 “EVLA Monitor and Control System, Test Software and Backend Software Requirements and Design Concepts”. This document can be found on the VLA Expansion Project Computing Working Documents web page:

<http://www.aoc.nrao.edu/evla/techdocs/computer/workdocs/index.shtml>

9.4.2.1 CMCS Hardware Requirements

The CMCS shall consist of a network of distributed processors with each processor responsible for managing a single circuit board unit of the Correlator hardware. These Correlator module interface boards (CMIBs) will provide the hard real time control necessary for Correlator operation. There shall be one master Correlator control computer (MCCC) to coordinate and manage the distributed network, host the operational VCI gateway, and centralize Correlator system management. This computer shall be considered a high reliability platform and shall be made fault tolerant through the use of hot standby or other methods to maximize system up time. A separate and similarly equipped computer will manage power monitor and control for the Correlator (CPCC) and will operate independently of the MCCC thereby isolating power control from any faults in the MCCC. The CMIB hardware modules should be of an electrical and mechanical form factor that lends itself to mounting on Correlator hardware devices in a replaceable and standardized fashion.

The CMIB design shall allow for future upgrade with minimal impact on the remaining installed systems. Modules shall provide sufficient non-volatile storage for completely self-contained booting of the operating system, run time code, and Correlator board firmware should that option be deemed necessary at a later date.

The modules shall provide a standardized method of communication with the Correlator monitor and control network and Correlator hardware. Correlator hardware shall be capable of being powered up and initialized into a quiescent state without any external network connections.

Unlike the processor chosen for the AMCS MIBs, the selection of a processor for use as the CMIB is not constrained by RFI considerations. The CMIBs will be located on the Correlator boards, inside a heavily RFI-shielded room.

9.4.2.2 CMCS Software Requirements

The Operating systems used for the MCCC, CPCC, and CMIBs shall provide reliable and maintainable operation for the expected life of the Correlator. CMIB operating systems and run time software shall be capable of responding to a 10 ms interrupt period, provide low level access for Correlator hardware communications, and provide reliable networking with the MCCC. The MCCC operating system and run time software shall provide a reliable and easily managed environment with easy integration into the EVLA MC network. It shall perform predictably under various network loads and fault conditions without operator intervention.

9.4.3 CMCS Design

The CMCS will make extensive use of hardware abstraction such that each functional unit of the correlator will be represented as a black box to higher layers of control software. The details of switch settings, data paths, hardware organization, etc. will be hidden except where this knowledge is needed by higher processes and when accessed through various service ports. Each CMIB will present a unified interface to its methods and control points such that upper level software is decoupled from any changes in CMIB design.

9.4.3.1 CMCS Hardware

It is expected that PC-104+ mechanical form factor computer boards will be used for the CMIB hardware. This industry standard lends itself well to creating a piggyback style module for mounting on the Correlator hardware boards.

Communication between the CMIB and Correlator hardware will be over the PC104+ bus (PCI standard). This bus will allow the CMIB to download FPGA personalities and control words to the Correlator hardware as well as extract monitor and ancillary data from the Correlator. It will be desirable to have all FPGA personalities as well as CMIB OS and run time code stored in CMIB flash style memory. This will allow “safe” power up and bench testing of individual Correlator units without any external networking in place. The MCCC and CPCC will most likely be high reliability PCs or VME/CPCI type SBCs with sufficient I/O connectivity to communicate with the Correlator MC network. The network itself will be based on 10/100 Base-T Ethernet using transformer coupled copper connections to reduce potential ground loop problems. The CMIBs, MCCC, and CPCC will need to support communication over this medium and protocol. It is anticipated that much of the MC network between the MCCC and CMIBs (around 300 units) will be routed through switches and hubs to reduce the port requirements on the MCCC. Further details of the topology and networking may be seen in EVLA memo #15.

9.4.3.2 CMCS Software

Due to the need for flexibility and portability on the network side MC code, selection of an OS for the MCCC and CPCC should place connectivity high on the requirements list. Since these computers will not be constrained by memory or CPU speeds, many commercial and public OS choices exist. The preference is to try Linux first since there is already a large installed base within the organization and it has proven to be both reliable and flexible. Selecting the OS for the CMIB is a bit more complex since the system has some modest real time requirements and is more restricted in CPU power and memory (to keep cost down). There exists a wealth of OS choices for these small SBCs among which are the various flavors of real time Linux. Due to the modest interrupt rates and need of good networking connectivity, several of the preempt-able Linux kernels seem like good choices for initial testing. It is expected to divide all run time code into logical processes/threads and assign priorities to best utilize system resources and network bandwidth. Watchdog processes will be used to monitor MC system health and take corrective action when possible.

9.5 Operational Interface Subsystem (OIS)

The Operational Interface Subsystem is one of several major components that constitute the EVLA Monitor and Control System. The primary responsibility of OIS is to provide a suite of client software tools that allow the array operators, engineers, technicians, scientists, software developers, and other authorized users to interact with the array in a safe and reliable manner.

9.5.1 OIS General Description

The Operational Interface Subsystem will provide the primary graphical user interface (GUI) tools for the EVLA Monitor and Control System. It is through OIS that users will monitor and command the array. This section will discuss the various components of OIS, the functions OIS must provide, and the users of OIS.

9.5.1.1 Components

- **Client Stations.** A client station is a user's desktop, laptop or handheld computer that runs the OIS software. Its primary responsibility is to run the OIS software and will do this either as a stand-alone program that executes on the client station or through a browser. The type and operating system of each client station will likely vary, as will the location. Client stations can be located at the VLA Control Building, the AOC or any Web-accessible location. Access from areas outside the EVLA control system will conform to network security guidelines described in the section entitled Monitor and Control Network (MCN) Access.
- **Operations Server.** The OIS software will communicate directly with the operations server. The server will have the responsibility of transmitting data acquired from the core monitor and control real-time system to the outlying client stations. It will also receive commands issued from authorized client stations and forward those commands to the core real-time system.

9.5.1.2 Functions

- **Array Monitoring.** The Operational Interface Subsystem will supply the array operators and other users with high-level and low-level monitoring abilities. High-level screens will provide information on the overall health of the array whereas the low-level screens will give detailed information on specific components within the system. The screens will be composed of textual and graphical components and will use color and audible alerts to inform the user of unexpected events and conditions.
- **Array Control.** Many of the OIS screens will allow authorized users to control all or parts of the array. Control functionality will be built into the screens using graphical user interface (GUI) components (sliders, buttons, combo boxes, etc.) that accept keyboard or mouse input from the user.
- **Logging.** The Operational Interface Subsystem will provide a tool that enables authorized users to create and send messages to a message log. This will replace the functionality currently provided by the observing log that is generated by the array operators using Microsoft Excel.
- **User/Operator Communication.** The Operational Interface Subsystem will provide a simple messaging (or chat) tool that allows operators and observers to communicate during an observation. This will allow corrections or changes, suggested by the observer, to be made during the observation in an attempt to increase the quality of the data being collected.

9.5.1.3 Users

- **Array Operators.** The array operators are responsible for the overall success and safety of all observations and will be the primary users of the Operational Interface Subsystem software. They require both monitor and control capabilities of the array and perform their duties from either the VLA Control Building or the AOC.
- **Engineers.** Engineers are responsible for the design, development and testing of the mechanical and electrical components within the system. They require the ability to inspect/control individual system components both remotely and at the antenna during working and non-working hours.
- **Technicians.** Technicians are responsible for the day-to-day monitoring and maintenance of the mechanical and electrical components within the system and are usually the first to be notified in the event of a non-working or malfunctioning component. As with the engineers, technicians require the ability to inspect/control individual system components both remotely and at the antenna during working and non-working hours.
- **Scientists.** Scientists, both NRAO and non-NRAO, are granted time on the array to conduct scientific investigations or tests. Their primary interest lies in the scientific data obtained by the instrument. They require remote access to both monitor data and visibility data to assess the progress to help make decisions during an observation.
- **Programmers.** Programmers are responsible for creating the software that drives the system. They must have access (with control capabilities) to the system, both locally and remotely, for testing and troubleshooting during working and non-working hours.
- **Web Users.** Web Users are those individuals that are part of the general public. They will have the ability to monitor the system and will not have any control capabilities.

9.5.2 OIS Requirements

This section highlights the major requirements of OIS. A detailed description of OIS requirements can be found at <http://www.aoc.nrao.edu/evla/techdocs/computer/workdocs/index.shtml> in the document titled “EVLA Array Operations Software Requirements”.

9.5.2.1 OIS Hardware Requirements

It is unlikely that OIS will communicate directly with any hardware. It will, however, communicate directly with the software interface for specific pieces of hardware (e.g., the *Device* interface) that will in turn execute the request on behalf of OIS.

- **Supported Platforms.** The OIS software must be relatively platform independent as it will run on a wide variety of machines hosting various operating systems. Specifically, the OIS software must be capable of running on commodity PCs hosting Windows and Linux operating systems and Sun Microsystems workstations hosting the Solaris Operating Environment. An optionally supported platform will be the Macintosh/Mac OS.

9.5.2.2 OIS Software Requirements

The software requirements document referenced above contains a detailed description of requirements imposed on OIS; it is worth mentioning here the few major requirements that have the most influence on the design of the OIS software.

- **Remote Observing.** Remote observing will provide users with the ability to run the OIS software from locations other than the VLA control building such as the AOC, other NRAO sites or from any Web-accessible location.

Several reasons exist as to why remote observing is necessary:

- Observers can monitor the progress of their observing program and make or request changes during their observation to increase the quality of data.
 - Engineers, technicians and programmers will need the ability to access the system from remote locations during working and non-working hours to do first-order problem solving.
 - Operators may be stationed at the AOC in Socorro in the future.
- **Secure.** The Operational Interface Subsystem will need a robust security mechanism in place so that unauthorized users are not allowed access to parts of the system that may compromise the success of an observation, cause damage to an antenna or jeopardize the safety of personnel in or around an antenna.

A coarse-grained security mechanism is under consideration that separates users into one of two groups: trusted or non-trusted. Trusted users will have privileged access to the system, namely control capabilities, whereas the non-trusted users will have only monitoring capabilities. Membership in the trusted group will likely be a function of identity and location. Users who would otherwise be trusted may be treated as non-trusted if they are located outside the NRAO or are not part of the NRAO VPN.

- **Easy to Obtain, Install and Update.** Since the OIS software will be geographically dispersed, a simple procedure must exist that allows users to obtain and install the software via the Internet. Several methods exist, including downloading a file (e.g., tar or zip) and running an installation script, accessing the software from a browser using Java applets, or Java Web Start software which is an application deployment mechanism for Java applications. Such methods are currently under consideration, however, Java Web Start is extremely attractive due to the fact that it requires very little interaction on the part of the user and upgrading the software is simple and relatively transparent to the user.
- **Easy to Use.** A feature often overlooked in the design of software for the scientific community is ease-of-use. A goal of the EVLA project is to have graphical user interface tools that are easy to use and intuitive. Besides being intuitive the GUIs must also adhere to a specified set of user interface design guidelines to create consistent interfaces and behavior across the various tools. Software that is easy to use is also often easy to learn which could reduce the three months it currently takes to train an array operator.
- **Robust.** The system must be capable of surviving failures within the system. It should not be affected by network glitches, broken socket connections, or the resetting or rebooting of devices within the system. In the event of such failures, OIS should simply warn the user that a failure has occurred, but it should continue working without incident. For example, if communication to an antenna is lost it should not affect the acquisition of data from all working antennas. And when the antenna is functioning and back online, the system should automatically resume data acquisition as if nothing happened.

9.5.3 OIS Design

The design goal of the Operational Interface Subsystem is to meet the requirements stated in the “EVLA Array Operations Software Requirements” document. At the same time the system must be designed so that parts of the system can be replaced with newer technologies. “Designing for the future” will allow new technologies, both hardware and software, to be “plugged-in” to the system for a gradual upgrade process rather than waiting for the next VLA expansion project.

9.5.3.1 OIS Hardware

OIS will not communicate directly with the hardware. Its only hardware design constraint is that it be relatively platform independent so it can run on many types of computers with little or no changes. This has little impact on the design and more impact on the selection of the implementation language.

9.5.3.2 OIS Software

9.5.3.2.1 General Description

The design of the Operational Interface Subsystem and the EVLA Monitor and Control System as a whole should exhibit the following general characteristics:

Loosely Coupled. Loosely coupled implies that components within the system are not tightly joined at the hip, but instead communicate via a coarse-grained interface that rarely changes. The primary benefit of loose coupling is that changes to one subsystem or subsystem component will not require changes to the subsystem that uses the changed component. An example of a coarse-grained interface that lends itself nicely to a loosely coupled system is the *Device* interface. The *Device* interface provides a method that retrieves a collection of *Device* objects so that the addition or removal of a device for that particular subsystem in no way affects the software that requests the collection of devices.

Highly Adaptive. The EVLA as a physical system will change not only through the transition phase and EVLA phase II, but also on a daily basis. During the transition phase VLA antennas will be upgraded to EVLA antennas and eventually NMA antennas will be added to the system. The system should easily adapt to these long-term changes without incident and without specialized code. It should also adapt to short-term changes such as the addition of new devices or monitor points.

Discovery-Based. A discovery-based system allows objects (e.g., subarrays, antennas, antenna subsystems, etc.) to be located at runtime rather than referring to a hard-coded list of known devices. In such a system the client can dynamically locate and manipulate any component within the system as the system dynamically changes beneath it. The more the client can find out about the system at runtime, the more flexible and extensible the system.

Extensible. An extensible system allows new features to be added to the system. The system should be designed so that these new features can be “plugged-in” at a later date with little or no impact on the overall system. Some examples of extensible features are a screen builder that allows users to create their own screens and a system simulator that could be used to test software or train operators.

Scalable. The physical elements of the EVLA will change over time. The number of antennas will increase and hence the number of antenna subsystems. As with most systems, the addition of new elements, in this case antennas, could possibly lead to degradation in performance. The system must be designed such that the addition of new antennas has minimal impact on the overall performance of the system. Likewise, as the number of users increases the overall performance of the system should not degrade.

9.5.3.2.2 Middleware Considerations

The EVLA Monitor and Control System will be designed as a distributed object system where each physical component (e.g., antenna) and non-physical component (e.g., a subarray) maps directly to a software object. The system must be able to locate these objects and once located one must have the ability to make the objects do something by invoking the object’s methods. Middleware such as CORBA, XML-RPC, Java RMI, Web Services (SOAP/WSDL/UDDI), Jini, JXTA, and many more offer just such functions. The EVLA software effort is in the process of defining the communication requirements in order to determine the suitable middleware solutions that are

available. It's likely that a single middleware solution will not suffice and that a system-wide, multi-protocol design will be required instead.

There are several determining factors that will affect the decision as to what middleware is used and where it is used. These include performance, interoperability, industry backing, expected lifetime, in-house expertise and budget. Other considerations for middleware include the network architecture, either client/server (Web services) or peer-to-peer (JXTA), imposed by the middleware.

9.5.3.3 Application Software

OIS is being designed as a flexible, highly adaptive system. The system will attempt to decouple itself as much as possible from the core monitor and control system so changes to the underlying system will not affect the OIS software. It will be designed using object-oriented analysis and design principles that foster code reuse through inheritance and hide implementation changes through encapsulation. Follows are a list of preliminary design concepts that are currently under consideration:

Lightweight Client. In order to achieve loose coupling, OIS must have little or no knowledge of the underlying business logic that is the responsibility of the monitor and control system. OIS should only be concerned with the presentation of information and the sending and receiving of messages from other subsystems. The less OIS knows about the business logic, the less likely changes to the core system will affect OIS.

The client software must be as lean as possible so that the size of the entire package that must be downloaded is minimized. In some cases users will be downloading the software over a dial-up connection.

Display Framework. A display framework or infrastructure will be designed so that screens can be easily created and added to OIS in short order. All screens will inherit common behavior and properties from a base *Screen* object the same way in which all devices inherit behavior from a base *Device* object. Some commonalities that might exist for all screens, defined by the *Screen* object, are the rate at which the screen updates, the updating of data on the screen, loading of resources for a screen and the overall look and feel for each screen.

Since all screens will have common behavior defined by the *Screen* object, the display infrastructure will simply treat all screens in the same manner regardless of the content of the screen. The primary function of a display framework will be to manage the screens. The responsibilities of the framework include, but are not limited to, the addition, importing and removal of screens, screen selection and creation and the disposal of screens.

Screen Types. It is thought that two types of screens might exist: automatically generated screens and predefined screens. The automatically generated screens will be dynamically constructed at runtime. The purpose of such screens is to make available at runtime any additions or changes to a device (e.g., a new monitor point added to the device.) The primary benefit of automatically generated screens is that users will not have to wait until a predefined screen is updated or created before seeing the changes. The predefined screens differ from the automatically defined screens in that they are more susceptible to changes in the device. If the device changes, in most cases a change to the predefined screen will be required. The primary benefit of the predefined screens is that the screens are highly customizable compared to the automatically generated screens.

9.6 EVLA Monitor and Control Network (MCN)

The EVLA Monitor and Control Network links all antenna, correlator, and backend devices to the central Monitor and Control systems.

9.6.1 MCN General Description

The MCN, with one minor exception, will be fiber Ethernet. The exception (noted in 9.6.3.1.2) will be twisted pair copper. TCP and UDP packets will carry commands and status information between the control systems and devices. Each antenna will be treated as its own Class C network.

9.6.2 MCN Requirements

The MCN must be able to support expected M & C traffic both in functionality and in load. The MCN must also not hinder instrument performance either through RFI or availability.

9.6.2.1 MCN Hardware Requirements

9.6.2.1.1 MCN Performance requirements

The MCN must be able to sustain an aggregate 200Kb/s per antenna and 4000 packets/s per antenna. (Assumes 1 packet/10ms* 40 MIBs per antenna.)

9.6.2.1.2 MCN RFI requirements

The MCN must meet the RFI requirements defined in section 3.8 of the Project Book.

9.6.2.2 MCN Software Requirements

9.6.2.2.1 MCN Protocol support

The MCN must support both TCP and UDP packets. The MCN must support any protocol such as FTP, HTTP, RPC mandated by the MC software system. The central distribution switch must support both Layer-2 and Layer-3 routing. This switch must have VLAN capabilities on all ports.

9.6.2.2.2 MCN Access requirement

Access to portions of the MCN may be required from remote locations. The exact details of this access will be defined at a later time. Those details should not directly affect the physical design of the network.

9.6.3 MCN Design

9.6.3.1 MCN Hardware in control building

The MCN will be a mixture of 100-1000Mbit single mode and multi mode fiber. Multiport fiber switches will be used to connect all components of the Monitor and Control System (MCS). The switched fiber fabric should meet performance and software requirements as well as mitigating RFI. QoS (quality of service) functionality may be desirable to ensure proper prioritization of traffic. Specifically the QoS capabilities must extend to VoIP traffic.

9.6.3.1.1 MCS Central Hardware

All MCS computers in the control building will be connected with 1Gbit full duplex multi-mode fiber through switches. The link between this cloud and other sections of the MCN will be 1Gbit multi-mode as well though 10Gbit may eventually be required.

9.6.3.1.2 Deformatters

The MCN connection to the deformatter boards will be through 100Mbit twisted pair copper. These devices will be physically located in the (shielded) correlator room. They will be addressed as if they were in their associated antenna.

9.6.3.1.3 LO Tx/Rx and power

These devices will be in the control building but will also be addressed as if they were internal to their antenna via the VLAN capabilities of the central distribution switch.

9.6.3.1.4 Other MCS devices in control building

All other MCS devices in the control building such as the weather station, correlator, and backend cluster will be accessed via multi-mode full duplex fiber. Individual connections will be run at 100Mbit or 1Gbit as required.

9.6.3.1.5 MCS Control building to Antenna link

Each antenna will be connected to the Control building via a 1Gbit full duplex single-mode fiber. All antennas will be connected using attenuated long distance network interfaces that will work over the entire range of distances.

9.6.3.2 MCN Antenna Hardware

9.6.3.2.1 Antenna to MCS Control building link

Each antenna will have a fiber switch with a mate to the control building end of the link. All antennas will be connected using attenuated long distance network interfaces that will work over the entire range of distances.

9.6.3.2.2 MCN antenna network

Each antenna will have a single fiber switch. One port will be connected to the MCS network as described in the previous section, the remaining ports will be directly connected to the MIBs via 100Mbit multi-mode fiber. Additional ports on the switch will be available for transient devices such as laptops or test equipment. These devices will also connect via 100Mbit multi-mode fiber. Until fiber based phones are available the 100Base-T VoIP phones will be connected to the switch via a media converter. The antenna switch should be capable of isolating broadcast between MIBS while allowing direct MIB to MIB communication where needed.

9.6.3.3 MCN addressing

The scale of the MCN requires that device addressing be separated into logical blocks of reasonable size.

9.6.3.3.1 Antenna addressing

Each antenna will be a single Class-C network of the form `aaa.bbb.xxx.yyy` where `xxx` defines the antenna and `yyy` defines the device in the antenna. The `aaa.bbb` portion will have a fixed value of `10.80`. The `xxx` portion will be the antenna number +100. The `yyy` portion will be the slot number + 100. The IP address of a device will be calculable given its antenna and slot number. As referenced in 9.6.3.1.3 some devices may be addressed as part of an antenna even though they are not physically in the antenna. Two or three of these Class-C networks will be set up in the AOC to facilitate testing. These networks will be addressed as `10.64.x.y`.

9.6.3.3.2 Control building addressing

The MC systems in the control building that include both control computers, switches and AMCS devices will be addressed together as the zero'th antenna.

9.6.3.4 MCN access

Access to the MCN will be restricted and based on the point of origin of the remote connection. Types and levels of access from specific sites have yet to be determined. The selection of the `10.x.y.z` network automatically precludes direct access from non-NRAO facilities. We are capable of allowing (or blocking) direct traffic to the EVLA for those links for which we have complete end-to-end management.

9.6.3.4.1 MCN access from VLA systems

Specific access requirements still to be addressed. The VLA network and EVLA network are separated by the site router. Allowing or disallowing traffic flow between the networks can be easily controlled at either router.

9.6.3.4.2 MCN access from AOC systems

Specific access requirements still to be addressed. The AOC and EVLA sites are directly connected by the VLA and AOC routers. Allowing or disallowing traffic flow between the networks can be easily controlled at either router.

9.6.3.4.3 MCN access from NRAO systems

Specific access requirements still to be addressed. All NRAO facilities have direct connections to the AOC router and therefore direct access to the VLA site router and EVLA. Traffic flow can be controlled between the EVLA and any of the sites to meet access requirements. The Mauna Kea and Los Alamos VLBA stations are the lone exceptions. From a network perspective they appear as non-NRAO systems

9.6.3.4.4 MCN access from non-NRAO systems

Because the EVLA is in the 10.x.y.z network, direct traffic flow to the MCN is not possible from non-NRAO systems. By convention packets with this network address are not forwarded by internet routers. Indirect access to the EVLA network from non-NRAO facilities will fall into one of two categories.

Non-NRAO entities at non-NRAO facilities will first connect to a non-EVLA system likely located at the AOC. From there traffic will be limited in the same manner as it is for AOC systems. Since the link from the remote site to the AOC and from the AOC to the EVLA are disjoint, some form of interface or proxy will have to be designed for the AOC end of the system.

NRAO entities at non-NRAO facilities will be supplied with VPN (Virtual Private Network) client software. This will enable them to appear to be physically in the AOC even though they are not. Traffic flow will appear to be direct from the non-NRAO system to the MCN even though it will go through an intermediate system at the AOC. This form of link will not require a separate interface or proxy as the previous style will.

In both cases access can be restricted at the AOC independently of standard AOC traffic if so desired.

9.7 Transition Planning

9.7.1 Overview and Issues

Q3 2003 is the current goal for testing of the first EVLA antenna to begin, while Q4 2009 is the current goal for shutdown of the old correlator. The array will, therefore, be in a hybrid state for a period of approximately 6 years. Clearly, monitor & control of the hybrid array is a major issue, and it will require a considerable investment of man-hours. The current plan for development of a hybrid array M&C system is to grow it from initiatives already underway. Three components are critical – 1) the interim control & monitor processor (CMP) which taps the monitor and control data stream of the current VLA, 2) an upgraded, network accessible controller for the current VLA correlator, and 3) a user interface testbed for the EVLA monitor and control system. The CMP is ready. The upgraded VLA correlator controller is under development now, and the beginnings of a user interface testbed will be developed after the CMP becomes operational. When combined, these elements form a basis from which a system for monitor and control of a hybrid array can be developed.

9.7.2 Requirements

The scientific community stipulated three general requirements for the transition phase:

- The EVLA Monitor and Control must support simultaneous operation of the old VLA antennas and the EVLA antennas during the transition phase,
- Array down time shall be minimized as much as possible during the transition phase,

- Operations using the old VLA shall be possible using the current OBSERV/JOBSERVE script files (to maintain backward compatibility with VLA antennas while they exist).

An additional, important operational requirement is that the current Modcomp computers be decommissioned as soon as possible. Eventually, it will become increasingly difficult to support and maintain the Modcomp equipment. It is very desirable to avoid end-of-life issues by replacing the equipment before it has been declared obsolete and no longer supported by the manufacturer.

9.7.3 Design

9.7.3.1 Transition Hardware Modules

During the transition, EVLA antennas will contain the F14 module that is present in VLA antennas for control of some of the Front Ends. A transition module that enables monitor and control of the F14 module by the EVLA monitor and control system will be designed and constructed.

The Digital Transmission System (DTS) deformatter will contain a filter that transforms an EVLA IF to an IF that is compatible with the current VLA correlator. This module will also match EVLA sidebands to VLA conventions when necessary.

9.7.3.2 Monitor and Control of VLA Antennas

In order for the Observing System to operate both the EVLA and VLA antenna types, it should be able to ‘view’ the array simply as a collection of antenna devices of both the VLA and EVLA types. The Interim Control & Monitor Processor (CMP) is the means by which this view of the array will be developed for the VLA antennas.

All monitor data from the VLA antennas eventually converges upon a device known as the Serial Line Controller (SLC). All commands to the antennas are sent via the Serial Line Controller. Fortunately, when it was designed, the SLC was equipped with two computer ports, both of which have access to either all or any user-defined subset of antennas. The CMP is an interface to the second port of the SLC. It provides access to the monitor data stream coming from VLA antennas, and the means to send commands to VLA antennas. With the addition of a second processor, it also provides the means to present an object-oriented interface consisting of Antenna Device objects to the remainder of the EVLA monitor and control system.

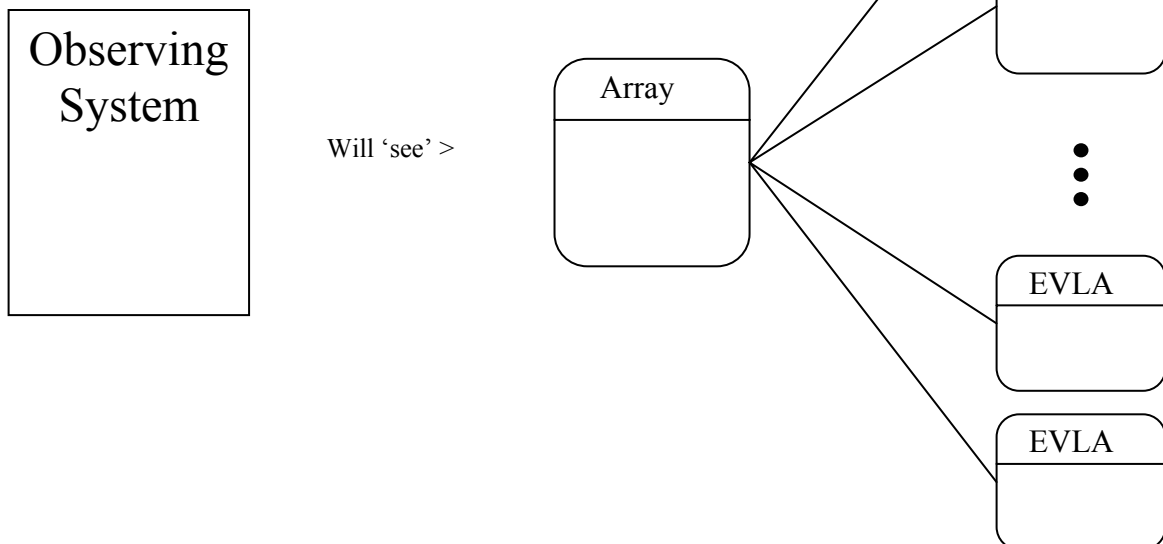

The EVLA Antenna Device objects will be served by the EVLA AMCS and the VLA Antenna Device objects will be served by the Interim Control and Monitor Processor.

The CMP consists of two VME Single Board Computer processors in a VME chassis. One processor is responsible for low-level real-time operation with the SLC; the other performs high-level interface functions to the EVLA M&C system.

The low-level processor is a Motorola MVME162 VME single board computer running the VxWorks Real Time Operating System (RTOS). It contains 4 slots for attaching Industry Pack (IP) daughter modules. Three IP modules are used to interface the CMP to the VLA's Serial Line Controller. The SLC takes commands from one of two processors (selectable) connected to it and provides monitor data to both processors. The MVME162 is connected to one of the ports and is currently online and receiving monitor data in parallel with the Modcomp computer that has been providing M&C for the VLA since its creation.

The MVME162 interfaces to the SLC via Industry Pack (IP) 'daughter' modules. One IP-UniDig-P I/O Module with handshaking is used to send command data to the SLC; another is used to receive monitor data from it. A third IP module provides general purpose I/O and interrupting, and is used to coordinate data transfer timing with the VLA's wave-guide cycle. Direct Memory Access (DMA) is used to transfer SLC data directly into short-term DMA buffers. DMA allows the MVME162's processor to concentrate on its sole responsibility of stripping SLC-specific information from the data and placing it in a shared memory area for monitor data and vice-versa for control data.

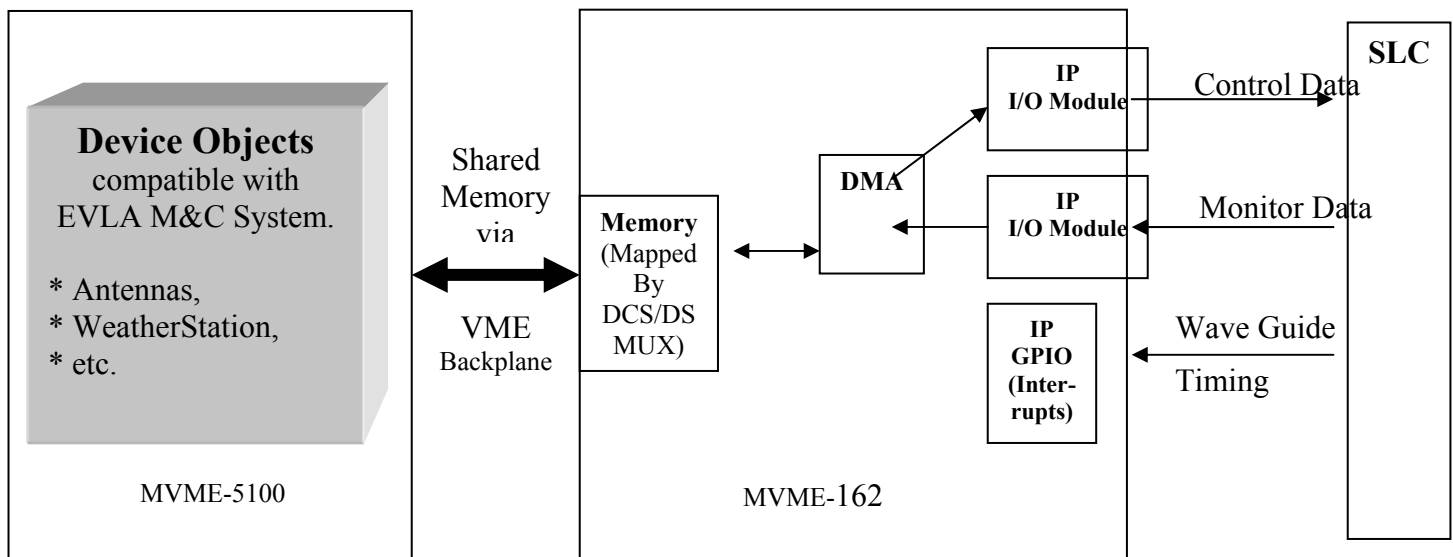

A second VME processor, in the same chassis, accesses the monitor and control data in the MVME162's memory via shared memory over the VME bus. This second processor is a Motorola MVME 5100-131 single board computer. It contains a PowerPC processor and uses a port of TimeSys Linux made especially for that board. All software is written in Java and runs on the CEE-J Java Virtual Machine (JVM).

The MVME-5100 essentially converts the low-level data produced by the MVME-162/SLC into software objects that the EVLA Monitor & Control System will recognize. The EVLA Observe System will therefore operate all antennas in the system as if they were the same without ‘knowing’ which are VLA and which are EVLA.

This system has the advantage that with the exception of the SLC driver software in the MVME-162, almost all of the rest of the software will be the same as that used in the EVLA AMCS. Because this system has been available before the MIB hardware, much of AMCS software development and deployment has taken place and is in the process of being ported to the MIBs.

9.7.3.3 Monitor and Control of the VLA Correlator

Both to replace obsolete, unsupported hardware, and to assist in the transition phase by providing a network accessible controller, a replacement Correlator controller is being built. The new controller is a VME based computer system designed to accept seamlessly the current Modcomp control and data dump formats. The control path is a network connection, which makes it possible to connect the controller to other external systems, including an EVLA monitor and control system. The VME system will consist of a Single Board Computer (SBC) with an Ethernet interface for command/control, a SCSI back end for data storage and/or archiving, and a separate array processor to receive Correlator integrator data and perform final processing. The new system will be installed into the system controller rack of the VLA Correlator.

Currently (8/2003) this system is in the test and development stage. Progress is constrained by the limited amount of time available for testing with the array, and by the other duties of the staff working on the project. The hardware aspects are well in hand, and the software is progressing. The new system has been demonstrated to work for continuum and for simple spectral line correlator modes. Work will continue during 2003 to expand the spectral line repertoire and to combine line and continuum operation. Commissioning is planned for Q2 2004.

9.8 The EVLA Test Antennas

Two test antennas are planned for the EVLA. The first test antenna has been moved from the antenna barn to the master pad, and is currently being outfitted with the racks and power distribution system needed to accommodate antenna modules and the antenna network.

To support development and debug efforts at the antenna, the EVLA Monitor and Control group must, at a minimum

- supply software for the MIBs that allows monitor data to be viewed in real-time, and accepts device commands
- provide a means of archiving the test antenna monitor data

Both items are reasonably well in-hand. As of 8/25/2003 we expect to begin testing of the first MIB-controlled antenna module, the L301 12-20 GHZ synthesizer. The software developed for this test includes the ability to view monitor data, the ability to send commands to the device, and device specific control software. The challenge will be to maintain a pace of module-specific software development that does not lag behind the availability of modules, while, at the same time, continuing to more fully develop the MIB framework software that is common to all MIBS.

A prototype test antenna monitor data archive already exists and has been tested using VLA monitor data reformatted to EVLA standards by the CMP. The test antenna monitor data archive was jointly developed by the e2e and EVLA M&C groups. Test antenna monitor data will be stored in an Oracle database. It is expected that the same scheme used to archive monitor data from the test antenna will be used to archive monitor data for the operational EVLA. To further test this expectation, the archiving of reformatted VLA monitor data will soon (within a month or two) be

made a standard part of VLA operations. Archiving VLA monitor data using a prototype EVLA monitor data database will provide, over time, a good measure of whether or not Oracle can adequately handle both the monitor data data rates and the monitor data volume. If it proves possible to use Oracle as the database engine for VLA and EVLA monitor data, it should not be difficult to provide enhanced data retrieval, listing, plotting, and analysis tools for VLA operations that will also serve as prototypical tools for operation of the hybrid array and the EVLA.