

# ALMA water vapour radiometer project

Kate Isaak and Richard Hills  
Cavendish Astrophysics, Cambridge

- Why water vapour radiometers?
  - Science requirements/instrument specifications
- Previous work
- ALMA Phase 1 work
  - Ongoing work (Cavendish Astrophysics/Onsala/Chalmers)
- Proposed ALMA phase 2 work
  - Laboratory testing; field testing at the ATF
  - Development of phase correction algorithms
  - Demonstration of phase correction

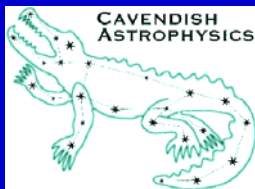

Science IPT meeting: Leiden 19<sup>th</sup> - 20<sup>th</sup> December, 2002



# Why water vapour radiometers?

- Corrections for phase fluctuations
  - Measure *differences* between lines of sight for each antenna pair
- Accurate measurement of the line-of-sight sky opacity
  - Obtain absolute values of atmospheric properties along each(?) path
- Tip-tilt error correction for individual antennas
  - Measure *gradients* of water vapour across the aperture of each antenna

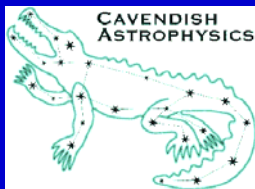

Science IPT meeting: Leiden 19<sup>th</sup> - 20<sup>th</sup> December, 2002



# Phase stability at Chanjantor

- Phase fluctuations at Chajnantor would limit the angular resolution of  $\sim$  all ALMA observations if uncorrected
  - Site testing at 11GHz gives a median zenith phase fluctuation of 2.5 deg. (190 microns of path) on a 300m baseline
  - Extrapolated median seeing at 345GHz is 0.7'' - equivalent to a baseline of only 300m (c.f. max  $>$  10km)
  - Median seeing at 900GHz is 1.4'' so useable baseline  $\sim$  50m
  - Even under most stable conditions, maximum useable baseline WITHOUT phase correction at 900GHz is 300m, which gives angular resolution of  $\sim$  0.4'' (c.f. goal of 0.01'')

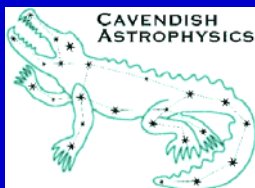

Science IPT meeting: Leiden 19<sup>th</sup> - 20<sup>th</sup> December, 2002



Measurements from 12GHz interferometer (LHS of photo) and 183GHz radiometer (RHS of photo). The values predicted from the radiometer compare well with the phase measurements.

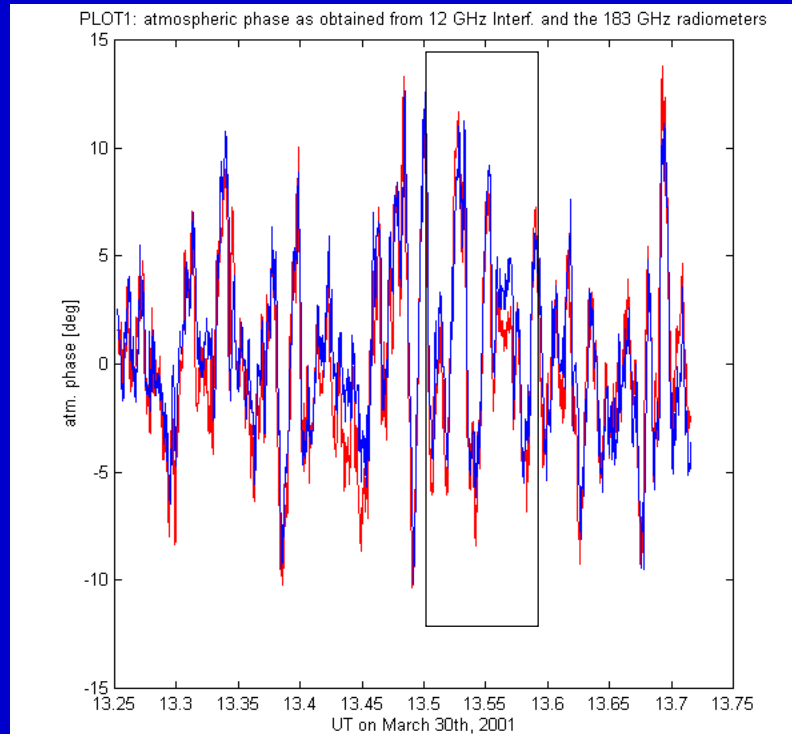

Red interferometer  
Blue radiometer

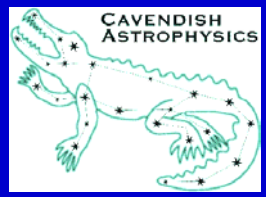
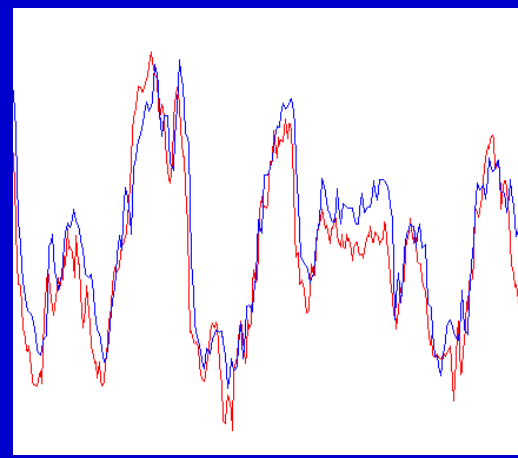

Science IPT meeting: Leiden 19<sup>th</sup> - 20<sup>th</sup> December, 2002



# Fast Switching

- Switching to reference sources is central to phase correction on ALMA
- Simulations by Mark Holdaway (Memo 403) show that fast switching ( $\tau_{\text{cycle}} \sim 10$  s) will work when conditions are good (80-90% efficient, achieving 30 degrees rms phase error)
- Assumption here is that only the most phase-stable weather is used for all high- frequency observing BUT..
- Opacity and phase stability are not perfectly correlated, so periods when conditions are dry, but unstable, will not be used most efficiently

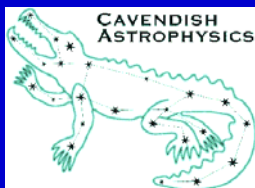

Science IPT meeting: Leiden 19<sup>th</sup> - 20<sup>th</sup> December, 2002



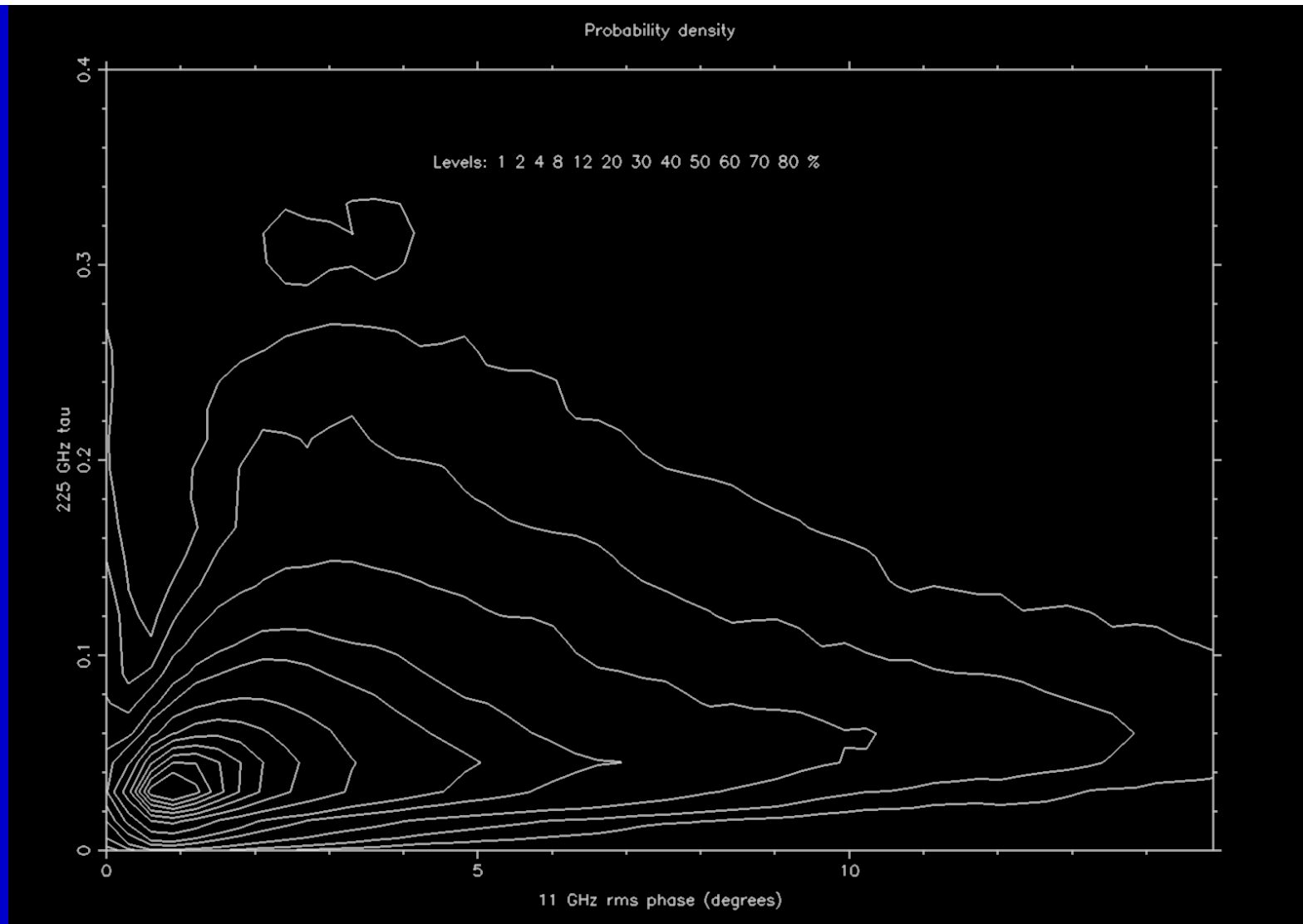

Contour plot of measured 11GHz rms phase and 225GHz tau

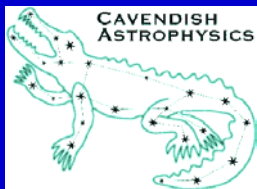

Science IPT meeting: Leiden 19<sup>th</sup> - 20<sup>th</sup> December, 2002



# Water vapour radiometry + fast switching

- Combination of wvr ( $\sim 1$  second timescales) AND switching ( $\sim 5$  minute timescales)
- Enables operation on all baselines over a much wider range of conditions
- Longer switching time results in less telescope wear-and-tear
- More accurate phase correction results in:
  - higher observing efficiency
  - more accurate amplitude calibration

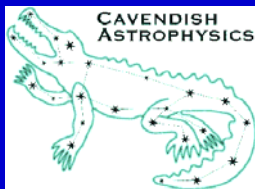

Science IPT meeting: Leiden 19<sup>th</sup> - 20<sup>th</sup> December, 2002



# Radiometer requirements

- Sensitivity:
  - measure variations in path to each antenna to  $10(1+w_v)$   $\mu\text{m}$  (rms) at  $\sim 1\text{s}$  intervals, where  $w_v$  is the precipitable water in the path in mm.
  - eg. for  $w_v = 0.6$  mm,  $\Delta\Phi(\text{rms}) \sim 24$  degrees at 900 GHz, which gives  $\sim 90\%$  correlation, i.e. 10% loss of sensitivity.
- Stability:
  - achieve above between observations of reference source ( $\sim 5$  minutes).
- Accuracy:
  - Maintain precision over changes in zenith angle of  $\sim 1$ deg. (N.B. a more sensible goal would be for changes in air mass, i.e.  $\sec z$ , of say 3%)
- Calibration:
  - Obtain accurate absolute measurements of water vapour and effective temperature to determine opacity for 1% calibration.

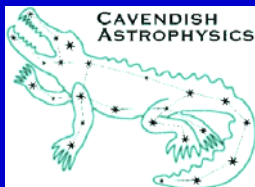

Science IPT meeting: Leiden 19<sup>th</sup> - 20<sup>th</sup> December, 2002





# Accuracy Requirement

- The key point is that we will have to track phase changes due to water when we go to a phase calibration source.
  - If the zenith angle changes there will be change in the water in the path of  $\Delta w_v = (\sec z_{\text{source}} - \sec z_{\text{calibrator}})$  times  $w_v$  at zenith.
  - This is common to all the antennas so there should be no change, but if individual radiometers make different errors in measuring it, then this will introduce a phase error which will be present in all the data taken up to the next observation.
- This means:
  1. We should limit the change in air mass,  $A = \sec z$ , when choosing our calibrators: If we are observing at high elevations sources with similar  $Az$  are best (to limit the slew) but at low elevations we should look for calibrators that are at very similar elevation to the source. For  $\Delta A/A = 0.03$  we have limits of  $\Delta(\text{El}) = 2.8^\circ$  at  $\text{El} = 60^\circ$ ,  $0.96^\circ$  at  $30^\circ$  and only  $\Delta(\text{El}) = 0.45^\circ$  at  $\text{El} = 15^\circ$ .
  2. We have to ensure that the *difference* in calibration of the radiometers are small: With the above changes in elevation and a 2% calibration difference we would make path errors of  $\sim 3.6 w_v \mu\text{m}$  at  $\text{El} = 30^\circ$ , which is becoming significant.

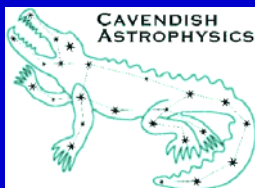

Science IPT meeting: Leiden 19<sup>th</sup> - 20<sup>th</sup> December, 2002



# Previous work

- 1995: start of the 183 GHz radiometer project for the JCMT-CSO interferometer (M. Wiedner PhD. Thesis)
  - 3-channel Dicke-switched radiometers,  $\sim 2$  Hz switching
  - Path errors of  $\sim 60\mu\text{m}$  rms due to noise
  - Additional replicas built for SMA interferometer
- Radiometers of similar design built and used for site-testing in Chile, and for the SMA project
  - Demonstration of good agreement between 11GHz phase data and 183 GHz data in Chile
  - Reasonable phase correction achieved at 230GHz using radiometers and ATM model fitting (Wiedner, Pardo et al.) under modest observing conditions ( $w_v=1.8\text{mm}$ )

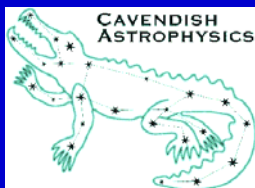

Science IPT meeting: Leiden 19<sup>th</sup> - 20<sup>th</sup> December, 2002



# Phase correction at the SMA using WVMs

Phase Correction during observations of Uranus at 230.5 GHz

25 Nov 2001, 1.8mm PWV, phase conv. factor: 1.901 deg/ $\mu\text{m}$

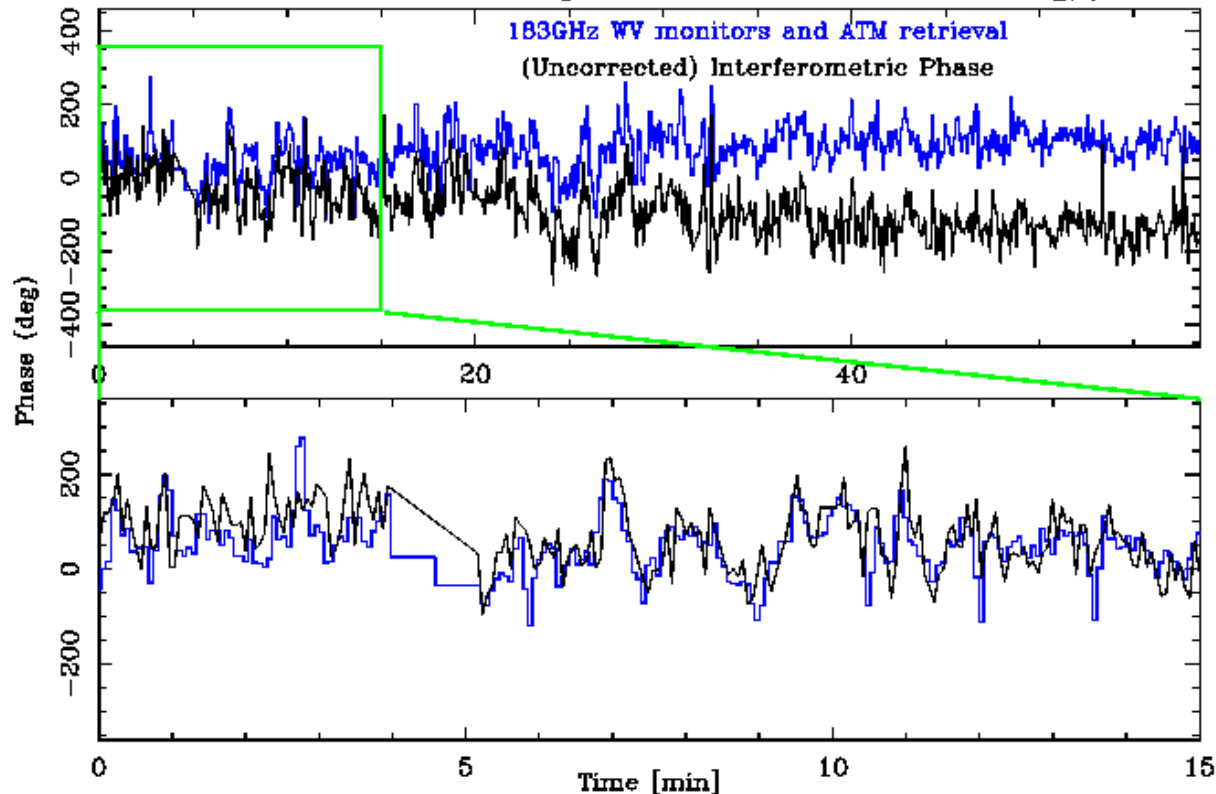

230 GHz phase measured with the SMA compared with predictions from “first generation” WVR’s. (Wiedner, Pardo et al.,)

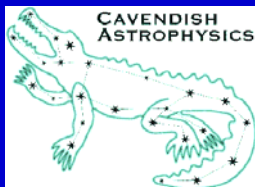

Science IPT meeting: Leiden 19<sup>th</sup> - 20<sup>th</sup> December, 2002



# ALMA vater vapour radiometers

- Rapid sky/load differencing
  - Choice of differencing schemes:
    - Dicke switch
    - Correlation receiver
  - Reference load operating at  $\sim 120\text{K}$ , close to sky temperature
- Four IF channels covering 0.8 – 7GHz
- LOs locked with small offset between WVMs on different antennas

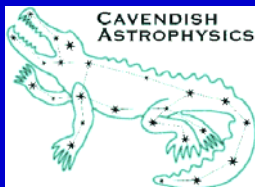

Science IPT meeting: Leiden 19<sup>th</sup> - 20<sup>th</sup> December, 2002



# Choice of filter bands (1)

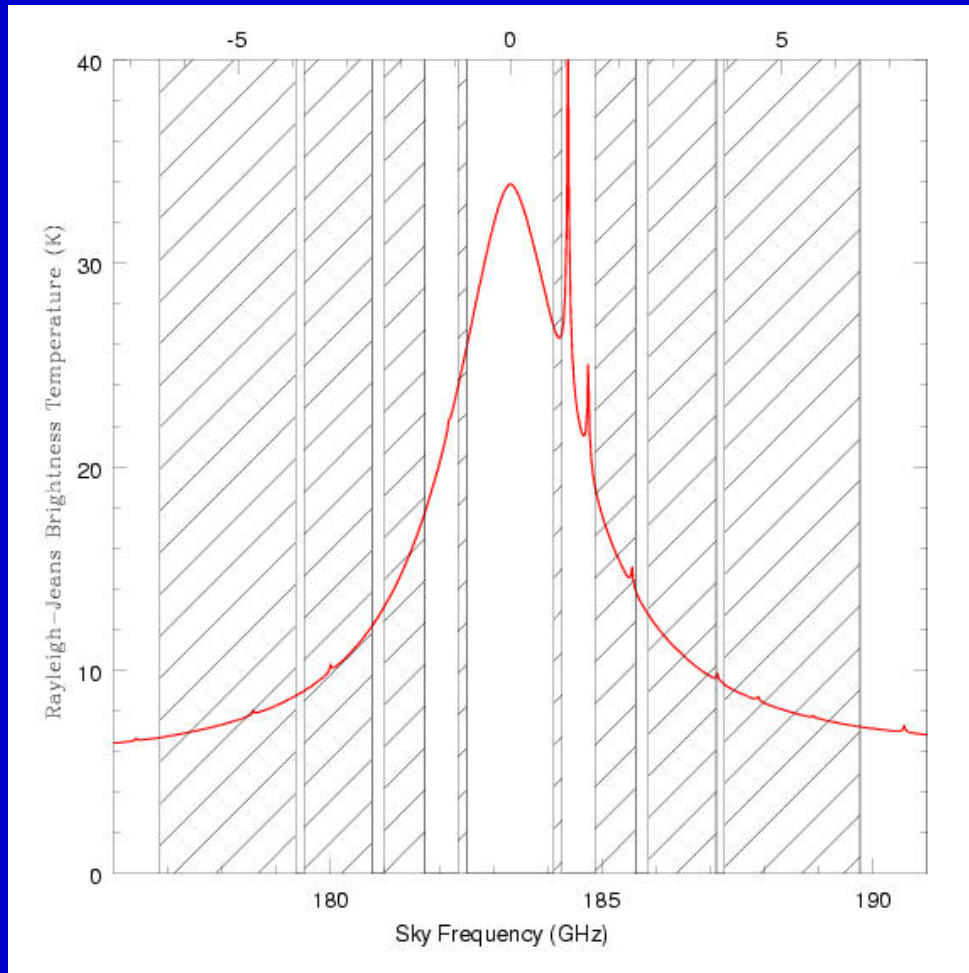

In the correlation design, up to 8 channels can be realized across the water line using sideband separation. For the present the assumption is that we measure only 4 double-sideband channels.

A plot of the filter bands superposed on the 183 GHz water line generated using ATM – a negligible PWV has been assumed in order to highlight the presence of two ozone lines in the water wings. The upper horizontal scale denotes the IF, whilst the lower scale denotes sky frequency.

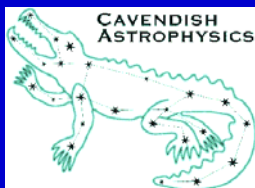

Science IPT meeting: Leiden 19<sup>th</sup> - 20<sup>th</sup> December, 2002



## Choice of filter bands (2)

- The four different filter bands are more or less sensitive to different amounts of water vapour along the path
  - Band 1 ( $\nu=0.96$  GHz ;  $\Delta\nu=0.18$  GHz); most sensitive for PWV < 1 mm
  - Band 2 ( $\nu=1.94$  GHz ;  $\Delta\nu=0.75$  GHz)
  - Band 3 ( $\nu=3.175$  GHz;  $\Delta\nu=1.25$  GHz); most sensitive for PWV < 3.5 mm
  - Band 4 ( $\nu=5.2$ GHz;  $\Delta\nu=2.5$  GHz); gives estimate of continuum contribution from water droplets or (perhaps) ice particles
- With the combination of the four filter bands it should be possible to determine the effective additional path between antennas over a wide range of observing conditions, and under good conditions obtain some information about second order corrections due to temperature and density which come in at the few percent level

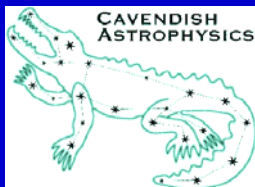

Science IPT meeting: Leiden 19<sup>th</sup> - 20<sup>th</sup> December, 2002



# Sensitivity requirements

- Given a system temperature of  $\sim 1700\text{K}$  (based on the measured performance of the subharmonic mixer/amplifier combinations we are using), noise fluctuations  $\Delta T_{\text{rms}} \sim 180, 88, 68$  and  $48$  mK in 1 second of integration time are in the filter bands 1 to 4.
- The conversion from brightness temperature to added path depends on both the amount of water vapour,  $W_v$ , and the frequency offset from the line centre. For  $W_v = 0.4\text{mm}$ , band 1 gives 30 mK per  $\mu\text{m}$  of path, at  $W_v = 1$  mm, band 2 gives 15 mK per  $\mu\text{m}$  and at  $W_v = 3$  mm, band 3 gives 7 mK per  $\mu\text{m}$ .
- The corresponding errors due to noise are therefore  $\sim 6, 6,$  and  $10$   $\mu\text{m}$  which compare well with the specifications of 14, 20 and 40 obtained from the formula of  $10(1 + W_v)\mu\text{m}$ .
- In practice there will no doubt be other error contributions due to drifts, calibration, spillover, etc., and we will attempt to quantify these in testing.

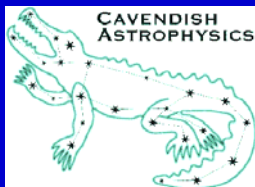

Science IPT meeting: Leiden 19<sup>th</sup> - 20<sup>th</sup> December, 2002



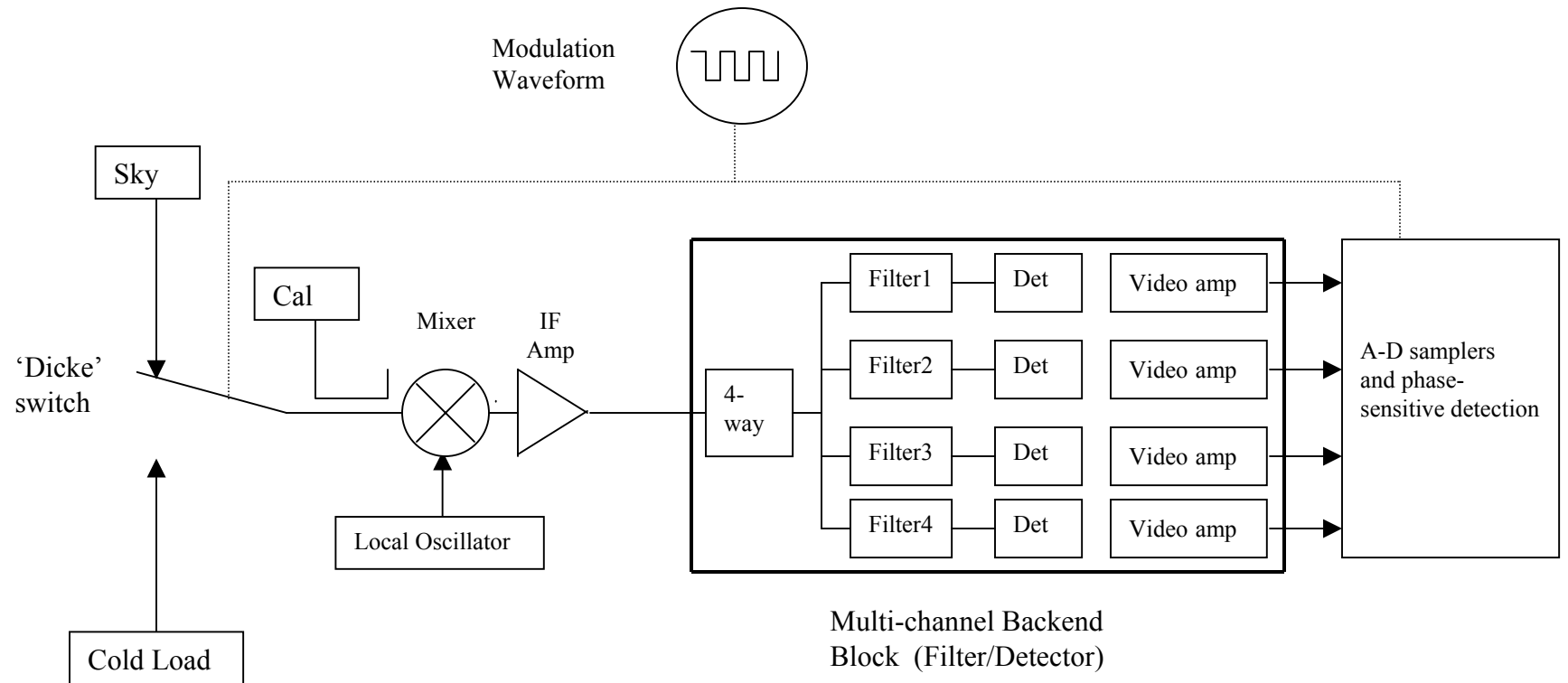

## Dicke-switch scheme

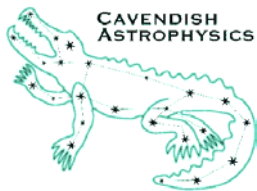

Science IPT meeting: Leiden 19<sup>th</sup> - 20<sup>th</sup> December, 2002





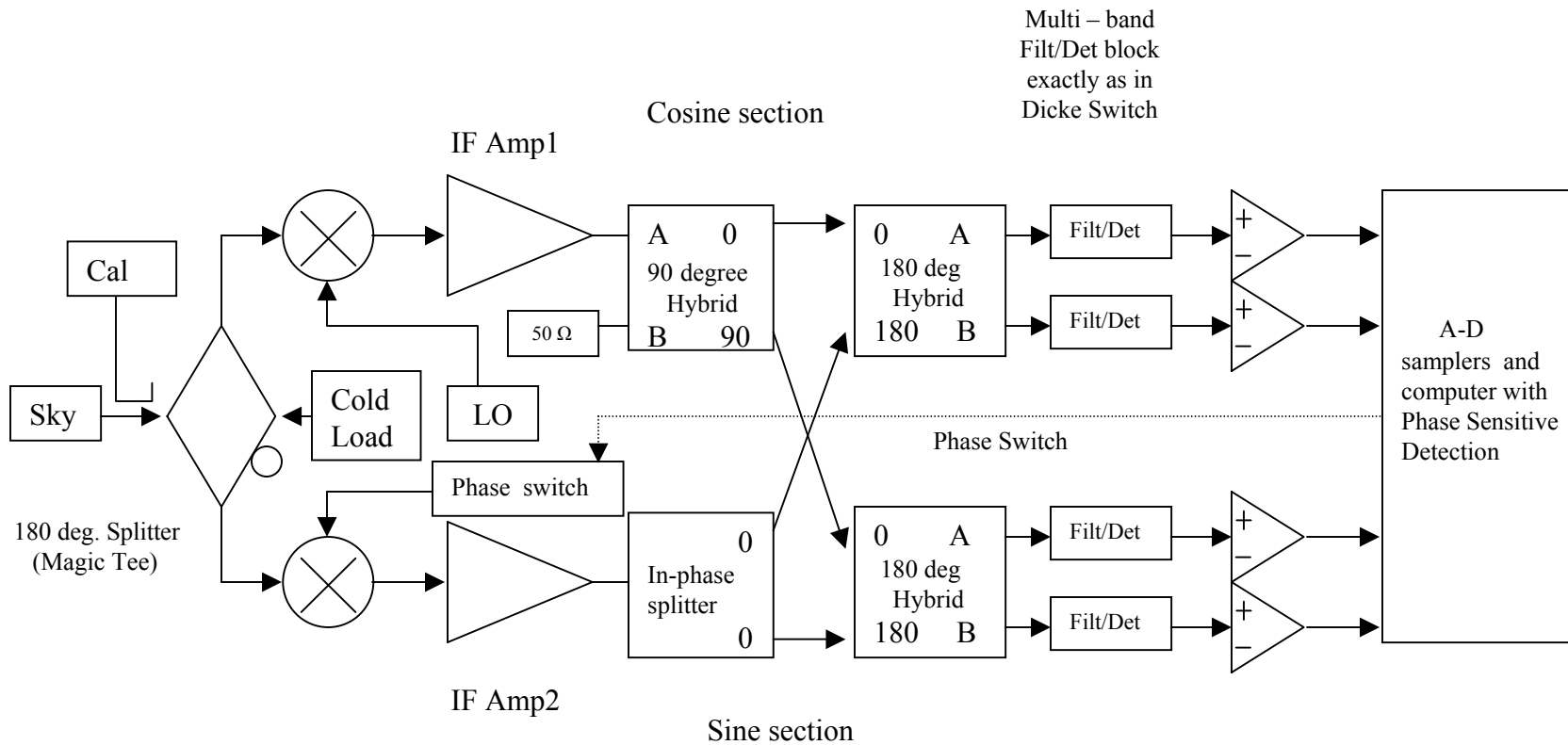

## Correlation scheme

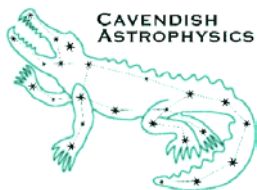

Science IPT meeting: Leiden 19<sup>th</sup> - 20<sup>th</sup> December, 2002



# Correlation vs. Dicke Switch

## Correlation Scheme:

- Advantages:
  1. No moving parts
  2. High modulation freq. possible
  3.  $\sqrt{2}$  improvement in sensitivity over single mixer
  4. Sideband separation possible
- Disadvantages:
  1. More components
  2. Good phase/amplitude matching required over filter bandwidths

## Dicke switch Scheme:

- Advantages:
  1. Simpler design
  2. Single LO required
  3. Can reduce costs by dropping second channel (although this loses  $\sqrt{2}$  in sensitivity)
- Disadvantages:
  1. Moving mechanical part (chopper wheel)
  2. No sideband separation

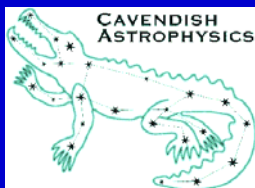

Science IPT meeting: Leiden 19<sup>th</sup> - 20<sup>th</sup> December, 2002



# Radiometer hardware

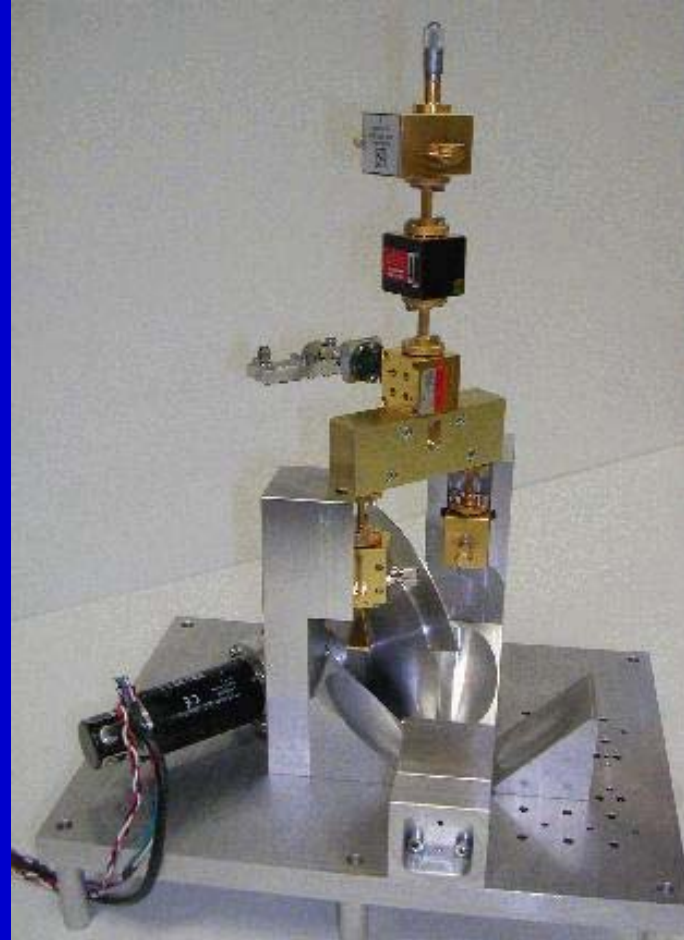
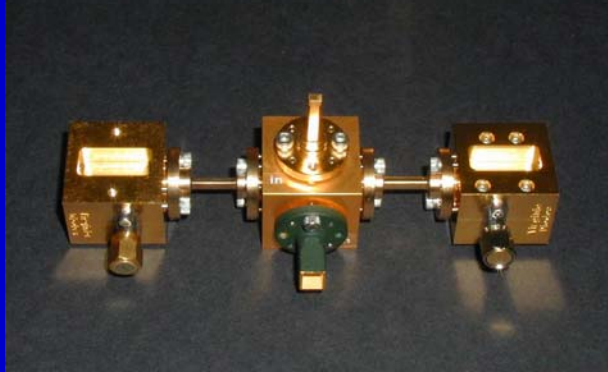

Far upper left:  
Mixer arrangement  
for the correlation  
receiver

Lower left: cold  
load

Left: Dicke switch  
radiometer with  
chopper wheel and  
two mixers

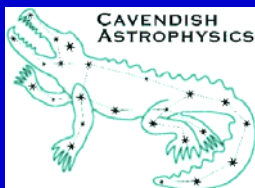

Science IPT meeting: Leiden 19<sup>th</sup> - 20<sup>th</sup> December, 2002



# Summary of Status

- It has been agreed that radiometry is required.
- Also accepted that radiometry of the 183 GHz line holds the best prospect of achieving the performance required over the full range of conditions. (Rather than e.g. 22 GHz line, submm continuum or IR emission. Sensitivity, matching to the astronomical beam and space for the optics are all factors here.)
- **The main requirement therefore is to find the most cost-effective, easy-to-maintain and reliable design.**
- There is nevertheless a good deal of concern that phase correction has not yet been demonstrated at the required level of accuracy. Doing this before committing to full-scale production is therefore highly desirable.

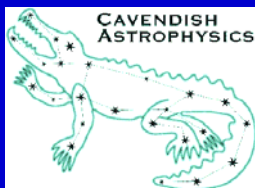

Science IPT meeting: Leiden 19<sup>th</sup> - 20<sup>th</sup> December, 2002



# Laboratory tests

- Stability
  - measurement of Allan variances over periods of 0.2s to ~10 minutes
  - look for correlation of fluctuations between different frequency channels
- Calibration measurements
  - Check accuracy against loads at known load temperatures (perhaps use polarizing grids)
- Effects of changes in ambient temperature and instrument orientation
- Select between Dicke-switched and Correlation.

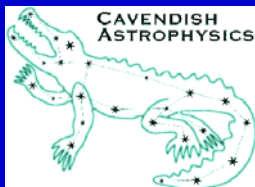

Science IPT meeting: Leiden 19<sup>th</sup> - 20<sup>th</sup> December, 2002



# Demonstration of high accuracy phase correction

- Clearly beneficial to do this: will at least increase confidence and may show up something that has been overlooked.
- Requires stable mm-wave interferometer – options limited:
  - JCMT/CSO: big effort to get running, observing time hard to justify
  - SMA: interfacing awkward, would have to run in “serendipity” mode
  - IRAM: interfacing and access not easy, ditto above
  - ALMA Test Facility: dry weather rather rare, 230 GHz limit.
- Present conclusion: ATF is the best bet – getting good results there is a serious test of both hardware and technique.
- This requires that ATF will have an operational, phase-stable interferometer. We assume this will be true by early 2005.
- If not might consider doing it in Chile early in commissioning.

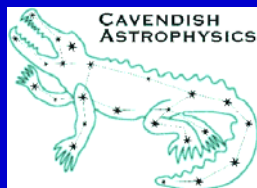

Science IPT meeting: Leiden 19<sup>th</sup> - 20<sup>th</sup> December, 2002



# From radiometric measurements to phase: modelling the atmosphere and correction process

- In principle the mapping from WVR measurements to delay is well understood. In reality there is a great deal to be done in this area before we can use the radiometers well:
  - Develop algorithms and software as part of calibration group
  - Analyse requirements for other information about the atmosphere
  - Investigate other strategies, e.g. machine learning techniques
  - Cost benefit studies, e.g. SSB vs DSB, single vs dual mixer

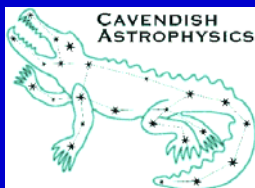

Science IPT meeting: Leiden 19<sup>th</sup> - 20<sup>th</sup> December, 2002



# Using the Radiometer Data

- Measured quantities are changes in brightness temperatures at 4 (8?) frequencies (+absolute temperatures to somewhat less accuracy).
- These brightness temperatures depend on:  $W_p(h)$ ,  $T_{\text{atm}}(h)$ ,  $P(h)$ , droplets, minor constituents....
- Path at observing frequency depends on same variables but with different functional forms. (Most important there is a  $1/T$  in the additional path.)
- One approach is to fit for some set of parameters using ATM and then calculate the path. (Note that typical height of fluctuations may not be the same as that of the water in general.)
- Possible alternative is to go direct from brightness fluctuations to path using set of non-linear coefficients, guided by model but improved by looking at recent data on bright sources.

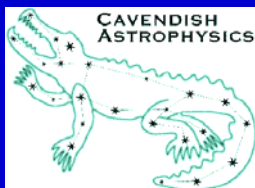

Science IPT meeting: Leiden 19<sup>th</sup> - 20<sup>th</sup> December, 2002





# Estimation of Atmospheric Absorption

- Clearly with 4 channels we should be able to get a good estimate of water content and reasonably good value for the effective temperature.
- These can certainly be used in improving the correction terms in our amplitude calibration scheme.
- Not clear whether there would ever be significant differences between the antennas on this? Probably could be on long baselines.
- Might think of having an extra radiometer with a tipper (even 2-D scan?) at the centre of the array.

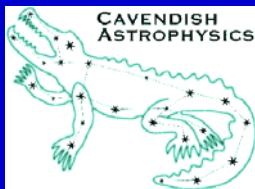

Science IPT meeting: Leiden 19<sup>th</sup> - 20<sup>th</sup> December, 2002



# Pointing “Tip-tilt” Correction

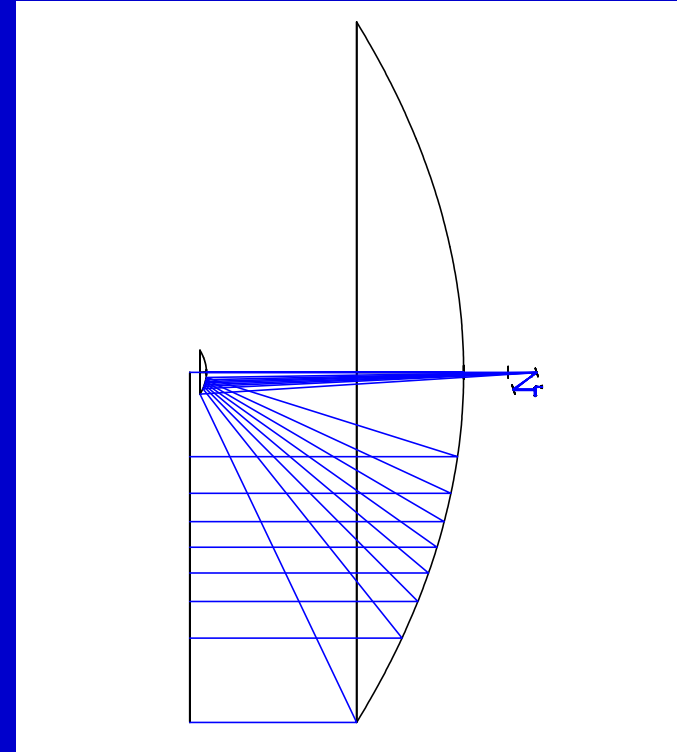
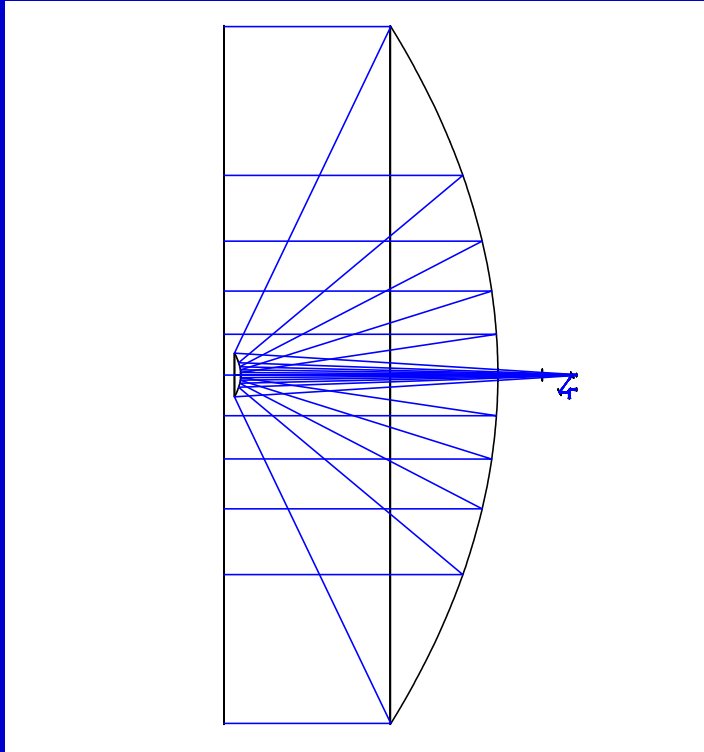

- Plan is to illuminate ~half the aperture and scan the beam of the radiometer round the dish, or switch it between the four sectors.

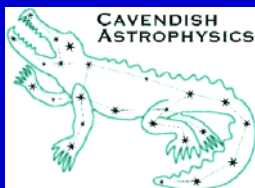

Science IPT meeting: Leiden 19<sup>th</sup> - 20<sup>th</sup> December, 2002



# Tip-tilt correction

- Difference up-down gives delta-El, left-right gives delta-Az. Estimate these and feed to drives. Typically  $0.1K = 0.2''$ .
- Retrospective correction is hard. Better to predict offsets for say next second ahead and send them to telescope drives.
- Note that there are some subtleties here about refraction corrections. Essentially we need to turn off the water terms when the tip correction is turned on.
- Also some interactions with the water terms in the interferometer phase which are normally corrected out.
- **We are trying to keep this open in the design work, but we really need to make a decision on whether to do serious work (design and test) during the next phase of work.**

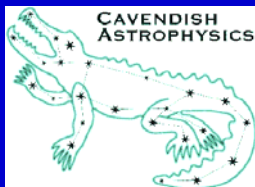

Science IPT meeting: Leiden 19<sup>th</sup> - 20<sup>th</sup> December, 2002

